



INSTRUMENTATION AND EVALUATION OF DISTRICT 10 CALTRANS AUTOMATED WARNING SYSTEM (CAWS)

Analysis of Driver Response to CAWS Warning Messages

Prepared for the California Dept. of Transportation and California Office of Traffic Safety
by Loragen Corporation, San Luis Obispo, California

Project Manager: Andrew Lee, Caltrans Division of Innovation and Research

Principal Investigator: Art MacCarley

OTS Grant No. RS0034, Caltrans Contract No. 51A0050

Document No. L-D10-FR-02

September 25, 2005

Table of Contents

Analysis of Driver Response to CAWS Warning Messages	1
2.1 Background and Evaluation Objective	1
2.2 Assessment of Success in Meeting System Objectives	5
2.2.1 Aggregated Metrics	11
2.2.1.1 Locally Aggregated Data and Metrics	11
2.2.1.2 Prior Use of Aggregated Data to Assess Safety of Traffic Flow	13
2.2.2 Individual Vehicle Metrics	13
2.2.2.1 Individual Vehicle Data	13
2.2.2.2 Prior Safety Assessments Using Individual Vehicle Data	18
2.3 Design of Field Data Collection Apparatus	19
2.3.1 Physical Components	19
2.4 Assessment of Driver Response During Reduced Visibility	25
2.4.1 Limitations of Measures of Traffic Turbulence and Their Physical Connection to Traffic Safety	25
2.4.2 Sight Distance Considerations in Fog	26
2.4.3 Factoring Visibility Into Traffic Safety Metrics	29
2.4.4 Rear-end collision risk and severity	31
2.4.4.1 Scenario 1 – Isolated rear-end collision, or first collision in a multi-car chain collision	33
2.4.4.2 Scenario 2 - Collision with stopped vehicle, or later collisions in a multi-car chain collision	35
2.5 Description of Data Collected	38
2.5.1 Event Case Studies	41
2.6 Cited References	42
2.7 Data Presentation and Analysis	44
2.8 CAWS Activation Events	50
2.8.1 Fog Events	52
2.8.1.1 November 1, 2003, Time: 12am-10am	52
2.8.1.2 November 16, 2003, Time: 12am-10am	62
2.8.1.3 January 08-09, 2004, Time: 10pm-8am	71
2.8.1.4 March 08, 2004, Time: 6am-8am	81
2.8.1.5 December 16-17, 2004, Time: 8pm-12pm	85
2.8.1.6 December 19-20, 2004, Time: 8pm-6am	101
2.8.2 Traffic (Speed-actuated) Events	110
2.8.2.1 March 13, 2004, Time: 9am-11am	110
2.8.2.2 April 17, 2004, Time: 5pm-7pm	114
2.8.2.3 June 28, 2004, Time: 4am-6am	118
2.8.2.4 September 15, 2004, Time: 4pm-6pm	123
2.8.3 Wind event	127
2.8.3.1 April 28, 2004, Time: 5pm-7pm	127

2.9	Observations over all events, 2003-2005	131
2.9.1	Speed, standard deviation of speed, and PCS as a function of visibility	131
2.9.2	Day vs. Night	136
2.9.3	Lane-specific	141
2.9.4	Segregated by vehicle class	142
2.9.5	Statistics over all message periods	148
2.9.6	Cumulative response segregated by fog or no-fog	154
2.9.7	A Detailed View of Traffic Response to Fog and Fog Advisory Messages	157
2.9.8	Driver Response to Messages Displayed When Visibility Conditions are Equal	158
2.10	CAWS Driver Response Conclusions	161
2.11	Appendix	163
2.11.1	Significant actuation events for CAWS CMS 1, November 2003 – February 2005.	163

Tables

Table 2.2.1.1. Example of Linear Bins for Field-aggregated Vehicle Speed Data.	11
Table 2.4.2.1 Illuminance Threshold E_T in Various Light Conditions.	28
Table 2.4.4.1. CHP Classifications of Accidents in CAWS Study Area, 1993-2003.....	31
Table 2.4.4.1. Visibility distances and corresponding extinction coefficients, alarm levels and CAWS warning messages.	40
Table 2.8.1.1. Normalized differences, After-CMS sites VS Before-CMS sites, during constant message periods.	60
Table 2.8.1.2. Normalized change in metrics measured during period 15 minutes after vs period 15 minutes before each message transition.	60
Table 2.8.1.3. Normalized differences, After-CMS sites VS Before-CMS sites, during constant message periods.	70
Table 2.8.1.4. Normalized change in metrics measured during period 15 minutes after vs period 15 minutes before each message transition.	70
Table 2.8.1.5. Normalized differences, After-CMS sites VS Before-CMS sites, during constant message periods.	78
Table 2.8.1.6. Normalized change in metrics measured during period 15 minutes after vs period 15 minutes before each message transition.	78
Table 2.8.1.7. Normalized differences, After-CMS sites VS Before-CMS sites, during constant message periods.	84
Table 2.8.1.8. Normalized change in metrics measured during period 15 minutes after vs period 15 minutes before each message transition.	84
Table 2.8.1.9. Normalized differences, After-CMS sites VS Before-CMS sites, during constant message periods.	97
Table 2.8.1.10. Normalized change in metrics measured during period 15 minutes after vs period 15 minutes before each message transition.	98
Table 2.8.1.11. Normalized differences, After-CMS sites VS Before-CMS sites, during constant message periods.	108
Table 2.8.1.12. Normalized change in metrics measured during period 15 minutes after vs period 15 minutes before each message transition.	108
Table 2.8.2.1. Normalized differences, After-CMS sites VS Before-CMS sites, during constant message periods.	113
Table 2.8.2.2. Normalized change in metrics measured during period 15 minutes after vs period 15 minutes before each message transition.	113
Table 2.8.2.3. Normalized differences, After-CMS sites VS Before-CMS sites, during constant message periods.	117
Table 2.8.2.4. Normalized change in metrics measured during period 15 minutes after VS period 15 minutes before each message transition.	117

Table 2.8.2.5. Normalized differences, After-CMS sites VS Before-CMS sites, during constant message periods. 122

Table 2.8.2.6. Normalized change in metrics measured during period 15 minutes after vs period 15 minutes before each message transition. 122

Table 2.8.2.7. Normalized differences, After-CMS sites VS Before-CMS sites, during constant message periods. 126

Table 2.8.2.8. Normalized change in metrics measured during period 15 minutes after vs period 15 minutes before each message transition. 126

Table 2.8.3.1. Normalized differences, After-CMS sites VS Before-CMS sites, during constant message periods. 130

Table 2.8.3.2. Normalized change in metrics measured during period 15 minutes after vs period 15 minutes before each message transition. 130

Table 2.9.1.1. Plot line numbers and color codes for figures to follow. 132

Table 2.9.5.1. Cumulative results for periods in which each message type was displayed, all differential visibility conditions, 2003-04. 148

Table 2.9.5.2. Cumulative results for periods in which each message type was displayed, visibility worse ACMS, 2003-04. 150

Table 2.9.5.3. Cumulative results for periods in which each message type was displayed, visibility worse BCMS, 2003-04. 150

Table 2.9.5.4. Cumulative results for periods in which each message type was displayed, visibility equal BCMS and ACMS, 2003-04. 151

Table 2.9.5.5. Cumulative results for periods in which each message type was displayed, all differential visibility conditions, 2004-05. 151

Table 2.9.5.6. Cumulative results for periods in which each message type was displayed, visibility worse ACMS, 2004-05. 152

Table 2.9.5.7. Cumulative results for periods in which each message type was displayed, visibility worse BCMS, 2004-05. 152

Table 2.9.5.8. Cumulative results for periods in which each message type was displayed, visibility equal BCMS and ACMS, 2004-05. 152

Table 2.9.6.1. Cumulative results discriminated by fog or no-fog periods at each site. Fog is defined as visibility less than 500 feet. 154

Table 2.9.8.1. Periods in which a 45-mph fog warning message was displayed while visibility was equal BCMS and ACMS. 159

Table of Figures

Figure 2.3.1.2 Block diagram of physical components and communications paths of CAWS evaluation system.....22

Figure 2.3.1.3. Pictorial view of evaluation monitoring sites (distances not to scale).....23

Figure 2.3.1.4. Evaluation monitoring installation at Mathews Road Overcrossing, the first of two “After CMS” monitoring sites. Inset is interior of Type 334C cabinet showing data acquisition equipment.24

Figure 2.4.4.1. Safe Stopping Distance, AASHO (now ASASHTO) formula calculated by D. Thompson, 1943.32

Figure 2.4.4.2. Impact velocity v.s. total car following distance for Scenario 2: Multi-car Collision.....37

Figure 2.5.1.1. Current activation mapping between speed monitoring sites and CMSs.45

Figure 2.8.1.1. Time history of event in two-hour increments (series of plots below).54

Figure 2.8.1.2. CMS 2-page message and sample traffic during event, from evaluation video camera59

Figure 2.8.1.3. Time history of event in two-hour increments (series of plots below).64

Figure 2.8.1.4. Sample traffic camera image during event. No CMS images since CMS did not actuate.69

Figure 2.8.1.5. Time history of event in two-hour increments (series of plots below).72

Figure 2.8.1.6. CMS 2-page message and sample traffic during event, from evaluation video cameras.77

Figure 2.8.1.7. Time history of event in two-hour increments (series of plots below).82

Figure 2.8.1.8. CMS 2-page message and sample traffic during event, from evaluation video cameras.83

Figure 2.8.1.9. Time history of event in two-hour increments (series of plots below).87

Figure 2.8.1.10. CMS 2-page message and sample traffic during event, from evaluation video cameras.96

Figure 2.8.1.11. Time history of event in two-hour increments (series of plots below).....102

Figure 2.8.1.12. CMS 2-page message and sample traffic during event, from evaluation video camera.107

Figure 2.8.2.1. Time history of event in two-hour increments (series of plots below).111

Figure 2.8.2.2. CMS 2-page message and traffic while message was displayed at 9:41 AM, from evaluation video cameras.112

Figure 2.8.2.3. Time history of event in two-hour increments (series of plots below).115

Figure 2.8.2.4. Traffic at CMS site while CMS message was displayed, from evaluation video cameras.116

Figure 2.8.2.5. Time history of event in two-hour increments (series of plots below).119

Figure 2.8.2.6. CMS 3-page message and sample traffic during event, from evaluation video cameras.121

Figure 2.8.2.7. Time history of event in two-hour increments (series of plots below).124

Figure 2.8.2.8. CMS 2-page message and traffic during message display, from evaluation video cameras..125

Figure 2.8.3.1. Time history of event in two-hour increments (series of plots below).128

Figure 2.8.3.2. CMS message and traffic during display of message, from evaluation video cameras. (The CMS image is actually from another wind activation due to camera problem during this event.) ...129

Figure 2.9.1.1. Mean speed as a function of visibility, traffic in all lanes at each site, day and night.....133

Figure 2.9.1.2. Speed standard deviation as a function of visibility, traffic in all lanes at each site, day and night.134

Figure 2.9.1.3. Photograph of CMS during very poor visibility. The message displayed on the CMS is
 “TEST TEST TEST”..... 135

Figure 2.9.1.4. Potential collision speed over all lanes at each site, as a function of visibility. 135

Figure 2.9.2.1. Mean speed as a function of visibility, traffic in all lanes at each site, day..... 137

Figure 2.9.2.2. Mean speed as a function of visibility, traffic in all lanes at each site, night..... 137

Figure 2.9.2.3. Speed standard deviation as a function of visibility, traffic in all lanes at each site, day..... 138

Figure 2.9.2.4. Speed standard deviation as a function of visibility, traffic in all lanes at each site, night. 139

Figure 2.9.2.5. PCS as a function of visibility, all lanes, day. 140

Figure 2.9.2.6. PCS as a function of visibility, all lanes, night. 140

Figure 2.9.3.1. Mean speed (left) and speed standard deviation (right) for lane 1 (top) lane 2 (middle) and
 lane 3 (bottom) as a function of visibility, day and night. 141

Figure 2.9.4.1. Mean speed (mph) by approximate vehicle length class. 145

Figure 2.9.4.2. Standard deviation of speed (mph) by approximate vehicle length class. 146

Figure 2.9.4.3. Potential collision speed (mph) by approximate vehicle length class. 147

Figure 2.9.7.1. Traffic characteristics before and after CMS warning..... 158

Analysis of Driver Response to CAWS Warning Messages

2.1 Background and Evaluation Objective

The Caltrans Automated Warning System (CAWS) provides information to drivers intended to modify their behavior in ways that improve traffic safety, especially in fog. In this section we assess the success of the CAWS at meeting this objective, by direct observation of the response of traffic to warning messages displayed by the first Changeable Message Sign (CMS) encountered upon entering the CAWS area on Interstate 5. It would be preferable to conduct a proper stimulus-response experiment, but we are not in control of the activation of the CMS – this is under the control of an autonomous system, the very system we seek to evaluate. We can only observe the response of vehicles with and without the stimulus, and relative to a control area with nearly identical characteristics (the area immediately up-road beyond the sight distance of the CMS). The core of this evaluation task is an observational before-after study with comparison group as defined by Hauer (1) based on Cochran (2). We will, however, go beyond interpretations of aggregated statistics and also rely to a considerable extent on intuitive observations revealed from detailed time histories of typical CMS activation events. By presenting these observations in graphical form, we allow the reader to observe subtle traffic changes that may be more useful (but difficult to quantify) indicators of driver response.

We designed and deployed a distributed data acquisition system to provide the necessary level of detailed data for the assessment of driver behavior. We selected optimum locations for our measurement sites in an effort to isolate the effect of the warning message (stimulus) from other potential influences on driver behavior to the maximum extent possible. In particular, the incremental response of drivers to the stimulus must be separated from the natural reactions of drivers to limited visibility and traffic-related factors.

“Safety” is a nebulously defined term that means different things to different people. To drivers, it is more likely to imply “security” or the minimization of personal risk, and for the transportation professional, it may be more formally interpreted in terms of accident rates (1), while in a fundamental sense it connotes a combination of individual collision risk and potential severity, which eventually manifest in measurable form as accident and loss rates accumulated over time. Of necessity, we will use the term “relative safety” in this analysis as an observable quality of a traffic flow that can be linked intuitively, physically or statistically with a reduction in accident numbers and severity.

The underlying assumption of this evaluation task is that given the stimulus of a CMS message advising a specific action, such as a speed reduction or an elevated level of caution, drivers will respond in ways measurable by appropriate and sufficiently sensitive instrumentation. It should therefore be possible to determine the success of that message by observation of the behavior of individual vehicles and/or the

overall traffic flow in terms of measurable parameters and metrics derived from these. Further, it is assumed that it is possible to infer small changes and differences in levels of relative traffic safety, as previously defined, from direct observations over the time history of events in which the message was present. This latter point is certainly arguable, but by following the lead of previous investigators in similar evaluations, we feel justified in seeking whatever indicators of relative safety that may be measurable in the present situation. These approaches have been used in several prior assessments of driver warning or guidance systems, both automated and manual (3,4,5,6,7), and accepted as reliable means for evaluating roadway enhancements intended to improve highway safety in fog (8).

A formal hypothesis for the study can be stated: During fog or other hazardous conditions, drivers will respond to CAWS dynamic messages by altering the motion of their vehicles in some safety-enhancing way. Our objective is to prove this hypothesis. In the absence of strong evidence supporting the hypothesis, we may alternatively test the contrapositive: if no or an insignificant change in traffic is observed attributable to the dynamic message, then it may be concluded that exposure to the CMS message does not affect driver behavior (and therefore relative safety) in a measurable way.

The potential limitations of this approach must be pointed out: it is possible that drivers do react to a warning message, but not in any way that can be directly measured. E.g., just because drivers do not alter their speed or separation (as advised or otherwise) does not necessarily mean that they are not responding in a safety enhancing way; perhaps they totally ignore the content of the message but benefit from some level of heightened attentiveness. Thus, no observable change in the traffic characteristics does not necessarily mean that the system did not have some effect on safety; but that the effect, if any, is unknown. It is, for example, plausible that a useful proportion of drivers is alerted by the message and would react faster should it be necessary but none saw it necessary to reduce speed. Since we examine traffic behavior on a microscopic as well as aggregated basis, we are sensitive to changes that might otherwise cancel each other in statistics based on longer periods of observation. The response of even a small number of drivers would be measurable in the real-time observations, even if buried in the overall results. Notwithstanding the known limitations, direct observational studies of this type are often the best (or only) valid approach for safety assessments, especially for projects affecting small geographic areas evaluated over short time periods. In the context of statistically analysis of accidents, the limitations and pitfalls of observational before-after studies have been discussed at length by Hauer (1) and Hirst, et. el. (9).

The assumption that relative traffic safety can be measured could be obviated if the purpose of the CAWS is defined directly in terms of the driver responses that it is intended to elicit. E.g., suppose the purpose of the CAWS is defined to be the reduction of traffic speed and speed variance during fog. In fact, the earliest published description of the system in a 1996 NCHRP Synthesis (8), the objective of the CAWS was stated to be to “automatically detect fog and alert motorists to hazardous conditions.” Although

implied, no specific safety objective was stated other than mention of producing “a speed alteration”. For reference, the purpose of the ADVISE system in Utah was reported to be reduction of speed variations and increased uniformity of traffic flow (10), and its evaluation focused on these measurable parameters.

Roadway safety enhancements may also be evaluated by statistics based on accident counts and rates. This approach focuses on the measuring the ultimate outcome, changes in accident rates. However, the measurement of cumulative accidents requires sufficiently large areas and long periods in which the stimulus is operational and the effect can be isolated from the inevitable changes in the ecology that occur during long periods of evaluation. Other difficulties of establishing valid conclusions about traffic safety from commonly used statistics were discussed by Hirst et al. (9) These constraints and considerations are apropos in the present case, since the CAWS area covers less than 15 miles of roadway, and the changes in the environment were extensive over the period of observation. However, in an effort to comprehensively evaluate the CAWS, we do, in Volume 4 of this report, perform a detailed statistical analysis of traffic accidents in the CAWS area.

The second underlying assumption of our evaluation method (relative safety can be assessed by observation of individual vehicles and their relationship with each other in traffic) requires a known, or at least physically intuitive relationship between accident risk and the motion of vehicles in traffic measurable at a fixed point of observation. The necessity of establishing a causal chain relating a roadway safety measure to accident occurrences was discussed at length by Elvik (11). While much valuable information can and has (12,27) been inferred from long-time or large-sample average measurements such as mean speed or gap measured over large numbers of vehicles, these cumulative measurements do not reveal the details of vehicle interactions as well as data recorded for individual vehicles. An increasing number of studies (38,29) have shifted the focus of traffic safety assessment to the importance of local interactions between vehicles which are not revealed by cumulative statistics. This may be especially true when reduced visibility is a factor. In most cases, the use of cumulative measurements is driven by the limitations of in-place data collection apparatus rather than the study objectives. If more detailed data were available, they usually would have been used.

Conventional data collection methods on highways accumulate, usually from simplex or duplex loop detectors, field-aggregated numbers such as average speed or speed histograms over fixed polling cycles. For reasons of sheer data mass, the behavior of individual vehicle are generally not reported, and not considered necessary for the traffic management monitoring purpose of these data collection networks. When accurate monitoring of traffic speed is required, duplex inductive loops or similar presence detectors are deployed, and vehicle speeds are measured via the time-of-flight between the two detectors placed a known distance apart in the roadway. However, duplex detector sites are relatively rare on California highways. Much more common are simplex (single loop) detectors, used primarily for monitoring traffic volume. With simplex loops, vehicle speeds are inferred by the assumption of a

standard average length for each vehicle. This approach provides valid estimates of mean traffic speeds only when sufficiently long data collection periods are used, during which the actual mean vehicle length is close to the assumed average length. Individual vehicle speeds cannot be determined, and consequently, calculation of the variance in vehicle speeds is impossible.

The CAWS automatically generates two classes of messages which either:

Class 1: Recommended a specific driver response such as an advisory speed.

Class 2: Provide advanced warning of a hazardous condition such as a traffic slow-down, stoppage, high wind, or other disturbance, leaving the response to the individual discretion of drivers.

The primary objective of the first class of messages (speed advisory messages) is straightforward:

1. Encourage drivers to conform to a specific speed that is appropriate to the roadway conditions.

The primary objective of the second class of messages (advanced warning advisories) as well as the underlying objective of the first class of messages is to encourage drivers to modify their behavior in some appropriate safety-enhancing way. The interpretation is at the discretion of individual drivers. However, this is usually expected to evoke one or more of the following responses:

2. Decrease speed to allow increased reaction time and reduce braking distance prior to encountering the disturbance.
3. Decrease speed difference relative to proximate traffic, reducing turbulence of the traffic flow.
4. Increase separation distance to allow increased reaction time and better accommodate the required braking distance if/when the disturbance is encountered.
5. Increase separation distance as a function of speed (2 and 4 combined), since the safe separation distance (in the sense of being able to avoid a rear-end collision) is a function of speed. This is nonlinear function, but if approximated by a linear ratio, it is equivalent to gap (time).
6. Elevate alertness to current conditions and potential hazards ahead. Reduce self-generated distractions such as conversation, cell phone use, use of audio system controls, adjustment of vehicle climate controls or seat position, use of non-safety-related in-vehicle driver information systems such as GPS map or direction-finding systems, or fixation on vehicle instruments such as fuel gauge, temperature, or possibly defective vehicle components (e.g., identifying the source of a “funny noise”).

The effectiveness of the system in meeting objective 1 can be assessed directly: measure the speed of each vehicle, and determine metrics such as mean speed and speed variance (standard deviation) or

other indicators of conformity to the speed recommendation. These metrics are directly measurable from data acquired on an individual vehicle basis.

The effectiveness of the system at meeting objective 6 cannot be non-intrusively measured unless it manifests as a change in speed, separation or lane-changing behavior. If it is assumed that prior to the warning message, the driver was not (fully) aware of the current conditions or impending traffic disturbance, so that their speed/separation was not optimal for the conditions, then 6 may be indirectly measured via speed and separation measurements. Even in the absence of any change in speed or separation, increased awareness is presumed to reduce driver reaction time, which may effectively reduce the safe separation distance. However, advanced warning leading to greater awareness of conditions or an upcoming hazard may also lead to increased traffic-adaptive behaviors such as lane-changing which result in increased traffic turbulence.

The effectiveness of the system at meeting objectives 2 and 3 may be assessed directly from statistics (e.g., mean, standard deviation) generated from raw measurements of individual vehicle speeds.

The effectiveness of the system at meeting objective 4 may be assessed directly from statistics generated from raw measurements of individual vehicle speeds and exact times of arrival.

The effectiveness of the system at meeting objective 5 may be assessed using metrics derived from the speed-separation relationship for pairs of successive vehicles (usually in the same lane). Gap time (individually measured from times of arrival and speeds) assumes a proportional relationship between separation and speed as an indicator of relative safety. More sophisticated metrics extrapolate the time until a potential collision if no corrective action is taken (Time to Collision) for a vehicle approaching another from the rear at a greater speed. Others, to be derived in this report, consider the braking motions of the two vehicles in the event of a traffic disturbance, resulting in a nonlinear function of speed, separation and visibility distance, as indicators of potential collision severity, or by inference, relative driver risk. These metrics will all be explored later in this report.

2.2 Assessment of Success in Meeting System Objectives

We now examine the relative value and limitations of each of the previously discussed methods and metrics for the assessment of each of the CAWS objectives.

Since, as mentioned above, conformity to a specific speed recommendation (CAWS objective 1) can be assessed in a straightforward way by direct measurement of mean speed, we focus the remainder of this discussion on the second class of CAWS objectives (indications of traffic safety improvement regardless of the content of the warning or advisory message).

The behavioral response of drivers to traffic management interventions of all types has been the topic of research for many years, for example (13,14,15). The presumption behind driver warning systems such as that CAWS is that exposure of drivers to an appropriate warning message during foggy conditions increases the time available for reaction and provides drivers with information on hazards beyond their visual range, such as a traffic slowdown or stoppage ahead. Conformance to a reduced speed is the usual objective of warning interventions, and it is expected that compliance will lead to an improved level of traffic safety.

It is widely assumed that accident risk and cumulative accident rates are monotone increasing functions of individual and mean traffic speed. This, in fact, is the current primary justification for all statutory speed limits and the primary focus of most enforcement efforts (fuel consumption was the primary justification for the former 55 mph National Speed Limit). This assumption is based on simple physics: at increased speed, available driver reaction time is reduced which increases the probability of a collision, and vehicle kinetic energy is increased, which is dissipated in destructive form in an inelastic collision. Vehicle dynamics (e.g., centrifugal force in a curve) and vehicle-to-road surface relationships (e.g., tire coefficient of friction) also change in ways that increase the probability of loss of control or reduced ability to avoid accident situation.

However, the significance of speed as the best predictor of accidents has been increasingly called into question. As early as 1950 (16), it was observed that over a sample of 40,000 accidents, if every accident in which speed was the only violation could have been prevented, the number of accidents would have been reduced by less than 10 percent. An investigation in Canada in 1972 (17) concluded that speed is not necessarily an important cause of accidents, but it is a determinant of severity. Since then, the relationship between speed and traffic accident risk as well as severity have been extensively studied.

In 1964 (18), the FHWA studied a large sample of accidents on rural highways and observed that vehicle speed and crash incidence were related by a U-shaped curve, with the minimum accident rate occurring near the mean traffic speed.

Garber and Gadiraju (5) in 1989 studied factors affecting speed variance and its influence on accident rates and severity. Following up on many prior observations as well as their own data, the authors confirmed that accident rates increased with increased speed variance for all classes of roads, and observed that speed variance increases with the difference between the posted speed limit and the highway design speed. They recommended that posted speed limits should be no more than 5-10 mph below the highway design speed, and that artificially low posted speed limits consequently *increase* accident rates. This extended prior observations that drivers selected speeds more consistent with their own perceptions of safety, which are more closely related to the highway design speed and driving

conditions than the posted speed limit. This was reinforced in a number of popular articles prior to the increase in the national speed limit, such as (19).

An FHWA Synthesis 2002 (20) addressed the role of traffic speed on traffic safety. It concluded that collision risk was not a monotone increasing function of speed, but more a function of the difference of the vehicle speed above or below the mean traffic speed, and that accident rates tend to increase with the difference between the 85th percentile or the mean traffic speed and the posted speed limit. The synthesis document also concluded, based on data from several other studies, that drivers travel at speeds they feel are reasonable and safe for the road and traffic conditions, regardless of the posted speed limit. These observations collectively imply that statutory or advisory speed limits set artificially low have the potential to *increase* accident rates.

As early as 1967, it was reported that in poor visibility, mean and 85th percentile speeds usually decreased by 5-8 mph, but that some drivers continue at speeds higher than the posted speed limit (21). More recently, Hogema and van der Horst (14) observed that drivers naturally reduce their speed in fog, but that speeds were excessive for the visibility-limited sight distance.

Conclusions regarding the diminished direct role of speed in accident risk may be less valid under limited visibility conditions. The reasoning is based on the underlying relationship between vehicle speed and separation distance as embodied in, for example, gap (time) measurements. In fog, unlike under normal conditions, drivers do not have the option of increasing their separation (maintaining an approximately constant gap time), since at some distance, visibility will supercede separation as the limiting factor. Separation distances beyond the visibility distance are of no incremental value, since a driver cannot react to the need to brake until they can see the vehicle or obstruction ahead. This view, shared by the author and the expert review panel, suggests that when excessive speeds are observed in foggy conditions, the mean traffic speed may indeed be a more useful indicator of relative safety than during clear conditions. For this as well as traditional reasons, we include real-time mean speed observations in the CAWS activation event case histories to follow, and we consider this in our later exploration of specialized metrics for traffic safety in fog.

As discussed above, it is now generally accepted that accident rates and individual risk of a crash increase as the spread of vehicle speeds in traffic increases. This is the most common indication of traffic turbulence and is generically referred to as **speed variance** in most published works, although the actual metric may refer to the statistical variance, the sample standard deviation, the average absolute deviation from the mean speed, or the inter-lane mean speed spread, each calculated over some time interval or number of vehicles. There seems to be a consensus that if all vehicles in a common traffic flow drive at nearly the same speed, crash risk is minimized. However, the literature is not unanimous on the relationship between individual accident risk and traffic speed variance. For example, Davis (22) presents arguments that positive correlations between crash rates and the dispersion of vehicle speeds

do not necessarily support the hypothesis that an increase in speed variance increases individual accident risk.

Also, as discussed by Hauer (23,24,25), it is natural to emphasize the importance of dynamics (the physics of stopping). The dominant effect of speed on safety is through the physics of injury production. That is, the higher the speed the more pronounced the damage caused by collisions. This is mainly what is reflected in the link between speed and accidents. The higher the speed, the larger the proportion of accidents that occur that are reportable and reported. Even if speed had nothing directly to do with the frequency of crash occurrence, we would still observe a monotone relationship.

Most prior evaluations of driver warning systems have focused on vehicle speeds and the variance of speeds as indicators of traffic flow turbulence, which has been linked to relative accident risk. Beyond the variance of speeds (usually measured as the sample standard deviation), some metrics of the symmetry (skewness) or peakedness (kurtosis) of the distribution of speeds may provide additional indicators of the traffic turbulence. The time relationships between successive vehicles have also been considered, such as inter-vehicle gap and Time-To-Collision (TTC).

Comparisons may be done in a number of ways. Usually, metrics are calculated over the period of display of a particular warning message, compared with periods prior to and after a message is displayed. Alternatively, they may be compared in the sections of the roadway immediately preceding and following the driver advisory sign. This second method is a form of comparison between an affected area (study area) and an unaffected but otherwise identical area (control area). There are limitations associated with each means of comparative assessment: Traffic on contiguous but different sections of a roadway may be subject to different conditions, such as differences in the roadway topology, number of lanes or sight distance, or local visibility. Traffic assessed at the same location but at different times may have a different volume or congestion situation, and local visibility can change very rapidly. Indeed, if the warning message displayed by a dynamic messaging device such as CMS is actuated by or related to the visibility, it is difficult to separate the natural reaction of drivers to the visibility from their reaction to the warning message. In our study, we use both approaches, and derivatives of each. We consider and attempt to control for the factors mentioned above in the design and location of our field apparatus.

If time-discontinuities in either mean speed or speed variance are used to assess the response of drivers to the activation of a dynamic warning message, it must be possible to assess these metrics over very short periods of time, almost approaching a “real-time” number which (presumably) reflects the instantaneous values of each. However, the use of either mean speed or speed variance (sample standard deviation) as a “real-time barometer” requires tradeoffs that constrain the period or observation:

1. An adequate period of observation must be allowed for the accumulation of a sufficient number of individual vehicle measurements to minimize “noise” and assure significance.

2. The period must be short enough such that the resultant number reflects sufficiently “real-time” conditions with minimum measurement lag. For speed variance, an additional issue associated with the potential for interaction of vehicles in the sample will be discussed later.

The choice of an appropriate moving sample window is therefore an important consideration, one that in our experience was resolved by trial and error on the actual data sets. The window sizes we used for our measurements will be discussed later in the context of each data set and the analysis performed on it.

The collection of individual vehicle data is impeded by the limitations of traffic monitoring instrumentation currently deployed on most highways, which were designed to facilitate traffic counts, volumes, and indirectly, average speeds over long periods. Inductive loop detectors consisting of two to three loops of copper wire buried in the lane interfaced with a Type 222 detector module are by far the most common type of vehicle detector deployed on California freeways. In common practice, traffic monitoring stations are equipped with simplex loops which record lane-counts, and can at best estimate traffic mean speed based on the assumption of an average vehicle length. Using the nomenclature of the FHWA Traffic Control Systems Handbook (26):

$$\bar{U}_s = \frac{100dN}{5,280\theta T}$$

where

\bar{U}_s = Space-mean speed (average speed over the sample period) in mph

d = Assumed mean vehicle length in feet

N = Number of vehicles counted by the detector during the time period T

θ = Occupancy (On-time or duty cycle of loop) in percent

T = Specified time period in hours

The measurement of average occupancy requires that loop detectors be set for “presence mode” which records the time-over-the-loop as opposed to “pulse mode” which records only a count for each vehicle. Occupancy is calculated by the field controller as the percentage of the loop “on” time to the total period of observation. Pulse mode is the more common mode, since it is less sensitive to re-triggering, and therefore more reliable for generation of accurate traffic counts and volumes. Mean speeds inferred from simplex loop data are only valid for very large sample sizes, and are directly dependent upon the accuracy of the assumed average vehicle length for that sample of traffic.

In the much less common situations in which traffic monitoring stations are equipped with duplex loops to measure vehicle speeds based on time of flight between the two loops, it is not common practice to retain or report individual vehicle speeds. Speed monitoring stations usually locally calculate the mean speed or store speed histogram information as incremented counts in speed “bins” or “buckets”. The standard protocol for data reporting from Caltrans speed-monitoring stations statewide is either field-calculated mean speed (per lane or overall), or speed-bucket (bin) data, polled over intervals ranging from 50 seconds to 15 minutes. For bin data, the total number of vehicles with speeds within specific ranges are counted and reported from each site during its polling interval, e.g., typical speed bins might be 45-55 mph, 55-65 mph, etc. This level of information is considered adequate for most traffic management and archival purposes. The detection, measurement, communication and recording of individual vehicle records are usually deemed unnecessary for most traffic management needs. This practice is, in fact precluded by the bandwidth limitations of present leased line communications with field controllers, which use 1200 bps multi-drop modems, periodically polled by a central computer via a star-configured network. The data storage requirements are also prohibitive.

Consequently, the existing roadway monitoring infrastructure does not adequately support the accurate measurement of metrics requiring individual vehicle data. The deployment of specialized instrumentation to record and report a separate measurement for each vehicle is preferred for evaluations of roadway safety enhancements.

In general, road traffic measurements may be separated into metrics that may be assessed using

1. traffic data accumulated over large samples and locally reduced (aggregated) into composite numbers reported by the field controller to a TMC, and
2. by metrics that require individual vehicle records (one number or set of numbers for each vehicle).

It must be noted that there is not a consensus as to the threshold at which traffic data is considered to be “aggregated” as opposed to “disaggregated”, e.g., one-hour periods of observation have been referred to as both “disaggregated” (27) and “microscopic aggregated” (12) in other studies. **Aggregated data**, as referred to herein, will refer to any raw traffic data other than individual vehicle records, which are reduced locally prior to communications and storage. Metrics which utilize aggregated data per this definition will be referred to as **aggregated metrics**.

Traffic data at the level of individual records of speed, time of arrival and length for individual vehicles will be referred to herein as **individual vehicle data**, and metrics derived from these data will be referred to as **individual vehicle metrics**.

2.2.1 Aggregated Metrics

2.2.1.1 Locally Aggregated Data and Metrics

Traffic data may be aggregated at the source in many ways. The simplest example is the calculation at the source (the field controller) of the mean traffic speed in a lane over a particular sample period (usually the polling period). This is the speed reporting method used by the CAWS at its 35 speed monitoring stations.

Another variation in common use for speed census data collection on California highways is a form of locally generated speed histogram. To illustrate, we consider data from a duplex detector site which is aggregated as counts in speed bins (buckets) by the field controller prior to reporting for each polling interval. For example, if we define bins for regular 10-mph speed intervals, and index these by i ,

Table 2.2.1.1. Example of Linear Bins for Field-aggregated Vehicle Speed Data.

i	Speed Range (v = vehicle speed in mph)	v_i assumed mean speed for bin i (mph)
0	$0 \leq v < 10$	5
1	$10 \leq v < 20$	15
2	$20 \leq v < 30$	25
3	$30 \leq v < 40$	35
4	$40 \leq v < 50$	45
5	$50 \leq v < 60$	55
6	$60 \leq v < 70$	65
7	$70 \leq v < 80$	75
8	$80 \leq v < 90$	85
9	$90 \leq v$	95

Only the bin totals are reported each polling cycle. Traffic flow metrics derivable from field-aggregated data include:

Mean Traffic Speed

The mean vehicle speed is calculated over all vehicles detected during the polling interval or longer. Alternatively, counts of vehicles detected within certain speed parameters are aggregated into speed buckets or categories.

The mean speed during the polling period may be calculated simply by summing all detected vehicle speeds and dividing by the total number of vehicles. Alternatively, an estimate of the mean speed may be calculated from the speed bin counts. In this case, if $n(i)$ equals the number of vehicles detected during the polling period with speeds in the i^{th} speed bin, and v_i is the assumed mean speed for the i^{th} speed bin, the overall mean traffic speed \hat{v} may be calculated as:

$$\hat{v} = \frac{\sum_{i=0}^9 n(i)v_i}{\sum_{i=0}^9 n(i)}$$

Approximate Speed Variance

If speed bin data are accumulated and reported by field detectors, it is possible to derive an approximation of the spread of vehicle speeds over the polling interval. The relative distribution of values in speed bins (buckets) are examined in post-processing. As previously mentioned, this ignores speed differences between vehicles categorized in the same speed bin, and assumes that all vehicles are sufficiently proximate to have interacted with each other in some way.

Let $n(i)$ equal the number of vehicles detected during the polling period with speeds in the i^{th} speed bin, and v_i is the assumed mean speed for the i^{th} speed bin. An estimate of the sample standard deviation would

$$\hat{\sigma} = \sqrt{\frac{\sum_{i=0}^9 n(i)(v_i - \hat{v})^2}{\sum_{i=0}^9 n(i)}}$$

Average Gap

Average traffic gap is measured simply as the average off-time of an inductive loop. It may also be calculated from the average occupancy (normalized fraction valued 0 to 1) and the polling period in seconds:

$$\tau_{gap} = \tau_{off\ time, avg} = \tau_{period}(1 - \text{occupancy})$$

Inter-vehicle Gap (in seconds) normalizes the effect of vehicle speed with vehicle separation, and therefore serves as a good indicator of potential accident severity and/or risk.

Among the comments from our external panel of experts was this observation about the above correlation of gap with accident rates: “One can easily produce a counter argument. The reciprocal of the mean headway is the traffic flow. If accident potential increases as the mean headway decreases, one should see this as an increase in accidents when flow increases. On most roads one sees the opposite.”

As a practical matter, long-period average gap measurements include the separation between platoons with the separation between individual vehicles in a platoon. This tends to dilute and obscure the risk associated with interactions between closely spaced vehicles in platoons or otherwise proximate groups. It is therefore probably of little value as an indicator of safety in sparse traffic unless measurements made between vehicles in platoons are discriminated from measurements made between platoons.

2.2.1.2 Prior Use of Aggregated Data to Assess Safety of Traffic Flow

A recent excellent example of the use aggregated data available from the existing roadway data collection infrastructure to assess relative traffic safety is the work of Golub and Ritchie (12). The authors studied, using existing Caltrans data from simplex loops, the relationship between traffic accidents and the traffic conditions near the time and detector station most proximate to each accident. They reported that the median distance of count stations to the accidents was 0.12 miles, and they examined the period 30 minutes prior to each accident, removing the most recent 2.5 minutes as unreliable, leaving a total observation period of 27.5 minutes. The objective in that work was to attempt to identify common attributes of traffic conditions that could be associated with increased accident rates. Among the conclusions of their detailed analysis was that relatively high crash rates were associated with high traffic turbulence, but that this was restricted primarily to conditions in which the mean speed is relatively low. They suggested that reducing variations in speed and flow should lead to safer conditions.

2.2.2 Individual Vehicle Metrics

2.2.2.1 Individual Vehicle Data

Almost all recent evaluations of the relative safety effects of a change to an existing highway have relied upon individual vehicle data, even if these data are later used to generate cumulative statistics. With the availability of records for each vehicle, it is possible to more accurately calculate the previously described safety-related metrics, and to calculate additional metrics which focus in a microscopic sense on vehicle-vehicle interactions.

Mean traffic speed

Individual vehicle speeds are measured, communicated with a central server, and recorded. They may be averaged in post-processing to generate the mean speed over a given period of observation. There is no advantage of using individual vehicle records to calculate this metric compared with the use of aggregated data, except for the additional flexibility to consider different or variable averaging intervals than those pre-ordained by the polling interval.

Let $v(i)$ equal the measured speed of the i^{th} vehicle, and N equal the total number of vehicles considered over some sample period. The mean traffic speed \hat{v} over this sample is calculated as:

$$\hat{v} = \frac{\sum_{i=1}^N v(i)}{N}$$

For our evaluation of driver response to the illumination of a CMS message, we required a short-term indication of traffic mean speed, one that could potentially indicate abrupt changes in levels of accident risk. In our analysis in later subsections, we plot the moving average of vehicle speeds over a period of 45 seconds, updated every 15 seconds. The 3:1 overlap between the period of observation and the time of calculation helps to slightly smooth the plotted measurement without obscuring discontinuities that might indicate a definitive driver reaction. The 45 and 15 second periods match those used for calculation of the proximate standard deviation of speeds, to be discussed later.

Variance of Vehicle Speeds

The most common indicator of traffic turbulence is the spread of traffic speeds about the mean speed, represented by the variance statistic. Its physical link to traffic safety is intuitive, since the conditions favorable to a collision increase as the speed difference between interacting vehicles increases. The ramifications the “interacting vehicles” assumption will be discussed later. In the traffic engineering literature, variance is actually used generically and speed variance is usually reported as the **sample standard deviation** $\hat{\sigma}$. Over a given period of observation or sample set, let $v(i)$ equal the measured speed of the i^{th} vehicle, and N equal the total number of vehicles. The sample standard deviation is calculated as:

$$\hat{\sigma} = \sqrt{\frac{\sum_{i=1}^N (v(i) - \hat{v})^2}{N}}$$

Skewness

Skewness is an indicator of the lack of symmetry of a distribution about the mean. A distribution is said to be “skewed” if one tail extends farther than the other. A value close to 0 indicates symmetric data. Negative values indicate a negative/left skew. Positive values indicate a positive/right skew.

Applied to a distribution of traffic speeds or headways, skewness may be considered another indicator (in addition to standard deviation or variance) of the turbulence or irregularity of the traffic flow. Its physical link to traffic safety is less clear, however, and it has been used in previous studies only as an enhancement to a variance statistic as further confirmation of traffic turbulence.

Kurtosis

Kurtosis, applied to a distribution of vehicle speeds, headways or separations, is another indicator of traffic turbulence, and therefore relative collision risk. As with skewness, it is usually used as a secondary metric to supplement standard deviation to further characterize the data spread. Kurtosis expresses how sharply peaked a distribution is. Values close to 0 indicate normally peaked data. Negative values indicate a distribution that is flatter than normal. Positive values indicate a distribution with a sharper than normal peak.

Sample Standard Deviation

Sample standard deviation is the square root of the variance. As a measure of relative traffic safety, it is a more intuitive metric than variance since it has the same units as that of the observations, in this case mph. It may also more fairly weight extreme outlying data points, avoiding the square effect of the variance. Henceforth we will report and treat as synonymous speed variance as “sample standard deviation of speeds with respect to the sample mean”.

Individual Vehicle Gap, Separation, or Headway

Among the many measurements made possible by individual vehicle records is the individually calculated vehicle gap. For vehicle i ,

$$\tau_{gap,i} = \tau_{headway} - \tau_{presence} \approx \frac{x_{i-1} - x_i}{v_{0,i}}$$

Where $\tau_{headway}$ is the time separation between the arrival times of each consecutive pairing of vehicles in a particular lane, and $\tau_{presence}$ is the presence time over the loop for the first-to-arrive vehicle in each pairing. Also, x_{i-1} is the position on the highway of the first-to-arrive vehicle and x_i is the position of the

trailing vehicle at the moment of observation, usually the time of arrival of the trailing vehicle. $v_{0,i}$ is the velocity (speed) of the vehicle at the time of detection.

Over sufficiently long periods of observations, the average of individually calculated vehicle gaps is equal to the average gap as defined previously.

Time to Collision, and Related Metrics

Time-to-Collision, like individual vehicle gap (in seconds), is one of several metrics of accident risk based upon physical relationships between consecutive vehicles, either in the same lane or adjoining lanes. Metrics of this type are precise in that the underlying measurements can be made accurately for individual vehicle pairings. They depend on an assumption that accident risk and subsequent accident rates can be predicted as a function of the relative vehicle speed difference and separation distance of sequential vehicle pairs. Average vehicle characteristics are assumed in the interpretation of these metrics.

In the assessment of the DRIVE Program active warning system in the Netherlands 1990-92, (3), in addition to mean speed, the average time-to-collision (TTC) for all vehicles was compared during periods in which a warning message were displayed, compared with before and after these periods. Van der Horst and Hogema (28,14) in 1992-4 and Minderhoud (29) in 2001 sought to relate the difference in speed between proximate vehicles with accident risk. They adopted and modified a version of the Time-To-Collision (TTC) metric originally proposed by Hayward in 1971 (30) for this purpose. As defined originally by Hayward, TTC was not intended as a measurable metric for the relative safety of traffic flows, but rather as a predictor of the amount of damage that may result in a model-based analysis of individual rear-end collisions. TTC requires knowledge of the instantaneous velocity of each vehicle in consecutive pairings, during a hypothetical emergency braking event:

$$TTC_i = \frac{x_{i-1} - x_i - l_{i-1}}{v_i - v_{i-1}}, \quad v_i > v_{i-1}$$

where x_{i-1} is the position of the lead vehicle, measured at the front bumper. x_i is the position of the trailing vehicle. l_{i-1} is the length of the trailing vehicle. v_{i-1} is the velocity of the lead vehicle. v_i is the velocity of the trailing vehicle.

All values are taken at the same moment in time, specifically the time at which the trailing vehicle starts to brake in response to the braking, already in progress, of the lead vehicle. While v_i can be measured

directly as the free speed of the trailing vehicle, v_{i-1} is a transient measurement during the deceleration of the lead vehicle, which cannot be measured directly.

In their evaluation of driver behavior in fog, Hogema and Van der Horst (3) used a modified form of this metric which makes it measurable for individual vehicles by conventional highway detectors. They redefined v_{i-1} as the free speed of the lead vehicle, measured at the point of detection on the highway, and assumed constant until the detection of the trailing vehicle with velocity v_i . The defining equation above remains the same, but the times of measurement of v_i and v_{i-1} , are now different, as defined above. Both velocities are measured using the separation of the duplex loops in meters divided by the time of flight between the loops.

In their original metric units:

$$TTC_i = \begin{cases} \frac{(t_i - t_{i-1})v_{i-1} - 3.6l_i}{v_i - v_{i-1}} & v_i > v_{i-1} \\ \infty & v_i \leq v_{i-1} \end{cases}$$

where t_i = time of arrival of trail vehicle (seconds)

t_{i-1} = time of arrival of lead vehicle (seconds)

v_i = velocity of trail vehicle at point of detection (km/h)

v_{i-1} = velocity of lead vehicle at point of detection (km/h)

l_i = length of the trail vehicle (meters)

Redefined in this way, TTC was a surrogate for lane speed variance measured only between immediately proximate vehicles. Higher values of TTC infer safer situations. A TTC value of 1.6 seconds or higher is considered a distinguishing limit between dangerous and normal conflicts.

Note, however, that the metric is non-infinite only when the trailing vehicle speed is greater than the lead vehicle speed at the point of detection, even if there is nearly zero separation between the vehicles. Thus TTC defines the extrapolated time until a hypothetical collision between these vehicles if the rear vehicle does not brake, despite the fact that it is approaching an impending collision with the lead vehicle (whose speed is also assumed constant). This metric is not relevant for vehicles in a platoon traveling at approximately the same speed. It served, rather, as a type of per-vehicle measurement of speed turbulence, and they selectively applied this metric only between the last vehicle in a lead platoon (vehicle $i-1$) and the first vehicle in the following trail platoon (vehicle i) or between sufficiently separated independent vehicles.

Minderhoud and Bovy (29) in 2001 defined additional situation-specific metrics, loosely based upon TTC, each more or less appropriate in particular conditions:

TET = Time Exposition Time-to-Defined as the fraction of the overall time that each vehicle travels with TTC below a critical value, typically 4.0 seconds suggested by Hirst (31) in 1997 as reported in (29).

TIT = Time Integrated Time-to-Collision. Similar to TET except instantaneous values of TTC for each vehicle are integrated over time to produce a cumulative metric over a given period of observation.

DTS = Deceleration-to-Safety Time.

TTA = Time-to-Accident.

PET = Post-Encroachment-Time.

2.2.2.2 Prior Safety Assessments Using Individual Vehicle Data

As mentioned above, Hogema, van der Horst and others (3,32) evaluated the DRIVE Program active warning system in the Netherlands 1992-94. This system deployed variable speed limit signs, with color and shape-coded warnings of estimated roadway hazard, usually established by local visibility. Since the primary purpose of this system was to improve traffic safety during foggy conditions, they assessed driver response using individual vehicle records of speed and time of arrival measured after drivers viewed the signs compared with proximate control areas which were not equipped with the dynamic message signs. From these raw data they derived and considered mean speed a modified form of Time-to-Collision for consecutive vehicles. This appears to be the first large-scale evaluation of the effectiveness of a dynamic driver warning system on traffic safety by microscopic analysis of driver behavior. They reported a systematic average reduction of mean speed of 8-10 km/h (5-6 mph) at sites which benefited from dynamic (lane-specific) speed warning messages, although headway, following distance, and Time-To-Collision were not significantly affected. These results were confirmed by accident statistics which showed a direct reduction in both the number and severity of fog accidents (3).

In a study of the driver behavior effects of a Variable Message Sign (VMS) at a bridge in an area of recurrent fog, Martin et al (4) utilized the mean speed and the standard deviation, skewness and kurtosis of the speed distribution. Comparisons were made during winters before and after the VMS was operational, and during the periods immediately before, during and after a warning message was displayed. They reported a decrease in the spread of speeds (speed variance) and a slight increase in the mean speed measured during the period that the warning message was displayed, relative to periods "before" and "after" the VMS activation.

2.3 Design of Field Data Collection Apparatus

2.3.1 Physical Components

In our assessment of driver response, we non-intrusively monitor the behavior of drivers before and after exposure to the dynamic warning messages displayed by the first CMS encountered upon entering the CAWS area from the north. We also observe the behavior of drivers in these areas under the same conditions with and without the presence of the CMS message.

Two “before-CMS” monitoring stations are located on the roadway before drivers encounter the first CMS. The second of these is located 0.5 miles from the top of a local high point in the roadway which blocks the view of the CMS from approaching drivers. The CMS is located 0.5 miles after the top of this hill. The first “before CMS monitoring station is located only 0.1 mile before the second one, primarily for the purpose of data redundancy.

Two “after-CMS” monitoring stations are located on the roadway after drivers have encountered the CMS; the first is approximately 0.5 mile after the CMS and the second is approximately 0.6 mile after the first, but well-before the sight distance to the next CMS of the CAWS system. This “after-CMS” test site placement permits us to assess both the immediate and gradual reactions of traffic that might be attributable to the CMS message. All stations collect Individual records of the time of arrival and speed of every vehicle in every lane. They also monitor local visibility conditions to assure constant environmental conditions. Video cameras are also deployed before, at, and after the CMS for visual verification of traffic and visibility conditions. The message displayed by the CMS is monitored both by direct interception of the TMC-CMS communications, and by a video camera for verification.

At each monitoring station, duplex inductive loop detectors are located in each lane with a known separation. Type 222 (Sarasota GP6C) loop detector cards are used at all locations, each with a sample-rate-limited time precision of 0.001 second. The locations of the evaluation monitoring sites are shown on a map of the CAWS area in Figure 2.3.1.1. A block diagram showing the physical data acquisition elements and communications methods is shown in Figure 2.3.1.2.

A pictorial view of the monitoring stations, before and after the CMS monitoring site, is shown in Figure 2.3.1.3. A photograph of one of the monitoring stations (at Mathews Road), and the interior of the Type 334C cabinet containing our data acquisition equipment are shown in Figure 2.3.1.4.

The proximity of the test points to the CMS helps to assure invariant roadway conditions, including those related to the highway configuration, and transient local conditions such as visibility and traffic volume. The data acquisition systems at each station record individual records of each vehicle’s speed, time of arrival, length, and lane. Data are retained locally until successfully transmitted and verified over wireless connections to a central server. The server also hosts the CAWS evaluation web site <http://caws->

evaluation.loragen.com that provides public access to real-time data, and restricted access to the database and web-enabled analysis tools.

Complete technical details on the CAWS evaluation system are contained in a later section of this report.



Figure 2.3.1.1. Location of five CAWS evaluation monitoring sites at north entrance to CAWS area. Composite photograph created from satellite photographs obtained from terraserver.microsoft.com.

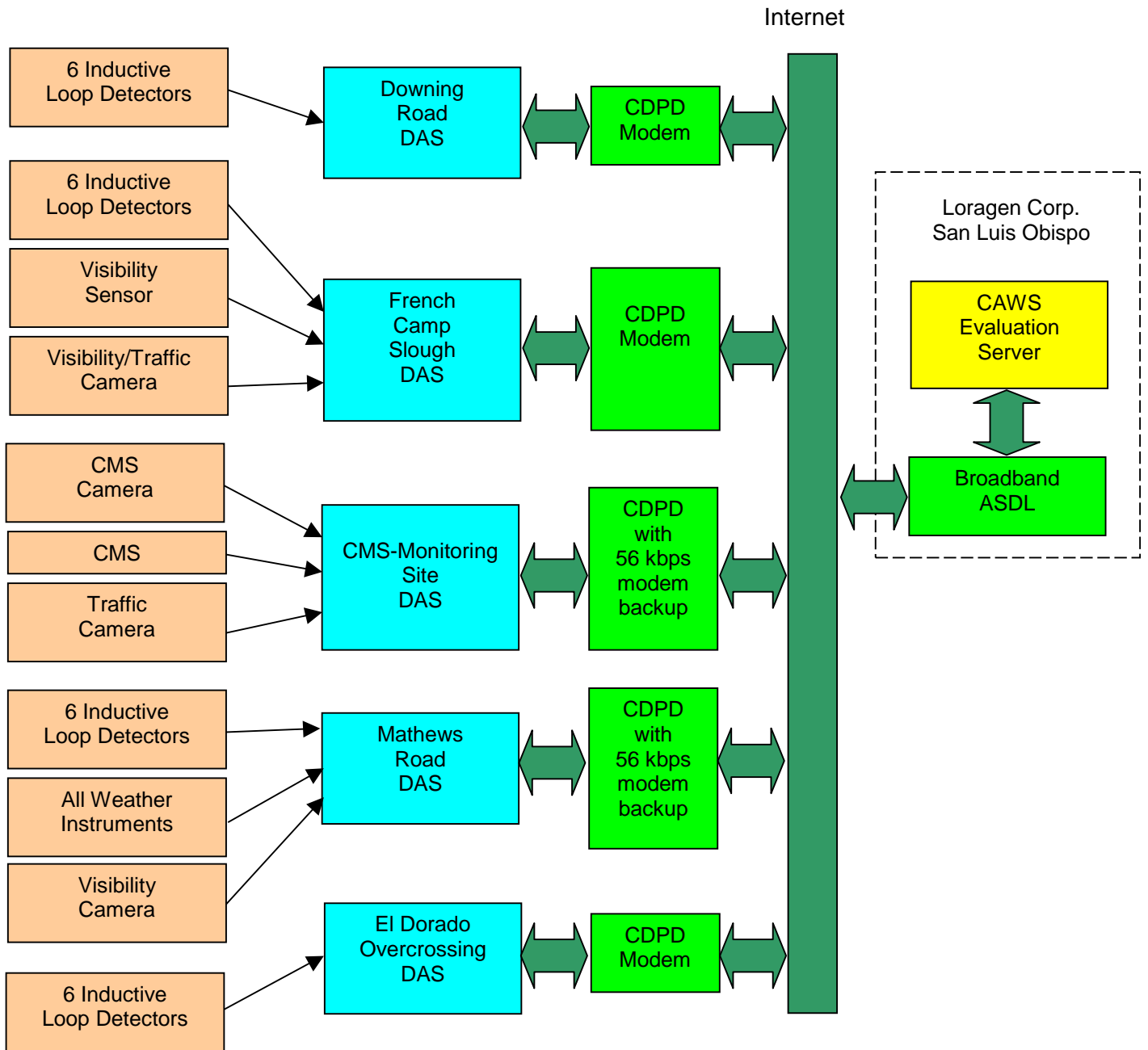

Figure 2.3.1.2 Block diagram of physical components and communications paths of CAWS evaluation system.

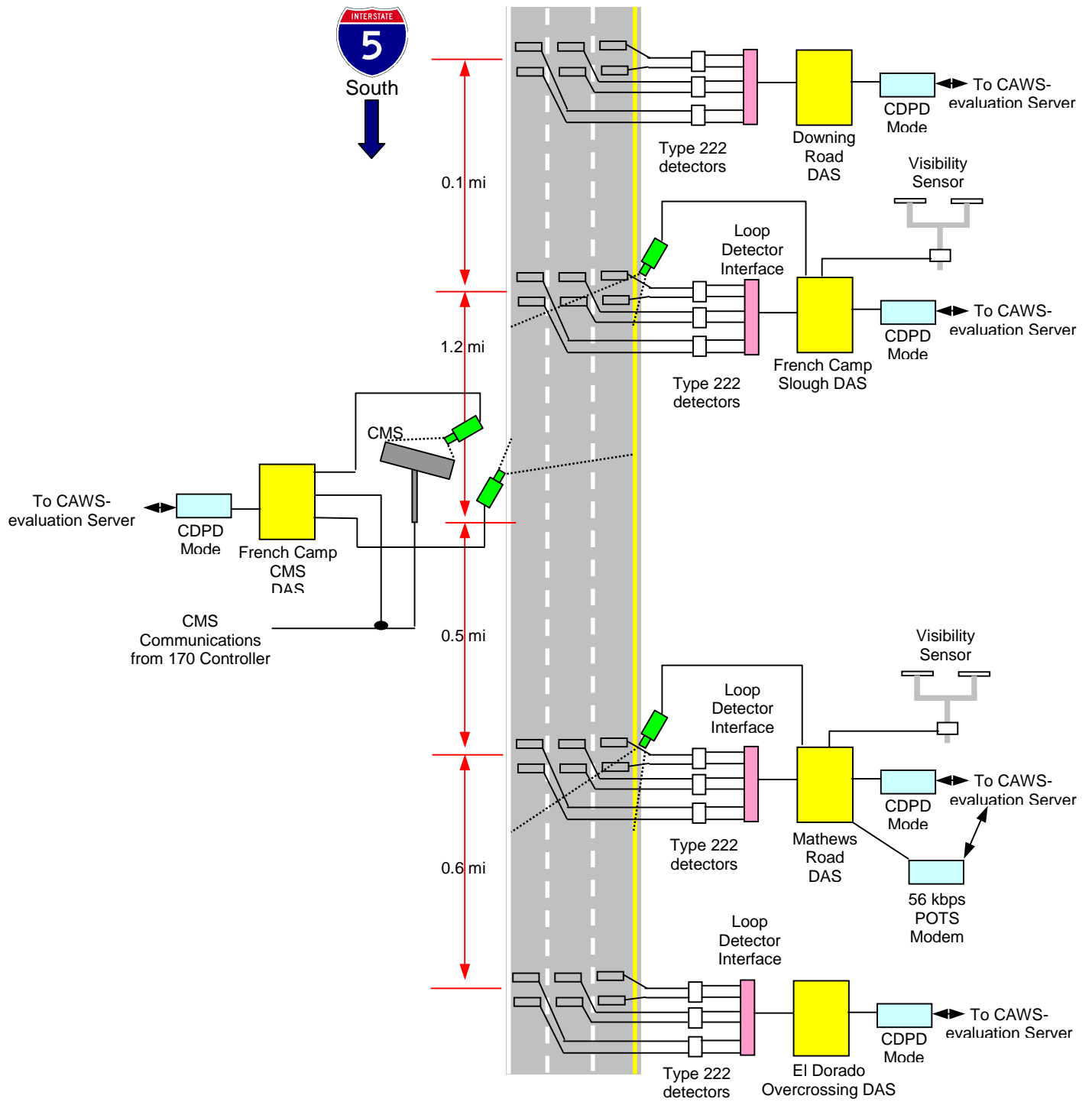

Figure 2.3.1.3. Pictorial view of evaluation monitoring sites (distances not to scale).



Figure 2.3.1.4. Evaluation monitoring installation at Mathews Road Overcrossing, the first of two “After CMS” monitoring sites. Inset is interior of Type 334C cabinet showing data acquisition equipment.

2.4 Assessment of Driver Response During Reduced Visibility

2.4.1 Limitations of Measures of Traffic Turbulence and Their Physical Connection to Traffic Safety

Speed variance (or standard deviation) is the most commonly used metric of the spread of vehicle speeds about the mean traffic speed, and has therefore become nearly synonymous with turbulence in traffic flows. The physical relationship between traffic turbulence and accident rates or risk is the potential for interactions between vehicles; the greater the difference in speeds between proximate vehicles (either in the same or adjacent lanes), the greater the possibility and/or severity of a collision. Fundamental to this relationship is the proximity of vehicles in the sample set. This was particularly emphasized by Heijer (38) who probed further and identified three possible modes of interaction, and from these proposed a safety-related model of driver behavior based on individual vehicle speed and position measurements. Vehicles must be physically close enough together for safety-related interaction to be possible. Proximity would best be determined by physical analysis of each situation under, e.g., the relative speeds of vehicles in adjacent or the same lanes within a small distance of each other on the highway. This is not practical as an on-going measure. The next best surrogate for physical proximity is temporal proximity – vehicles detected at a fixed position on the highway in all lanes within a small enough period of time to admit the possibility of mutual interactions. For periods longer than this, the variance calculation is increasingly diluted by non-interacting vehicles, reducing the validity of this metric as a measure of risk-of-collision traffic safety in general.

An extreme example of this is the case of two well-isolated platoons traveling at significantly different speeds during the period of observation. The speed differences between individual vehicles in each platoon are insignificant. Since the speed differences between interacting vehicles were all nearly zero, vehicles could be considered to be at minimum accident risk (at least due to turbulence considerations). Yet the speed variance calculation for this period would be very high, with every vehicle differing from the mean speed by half the speed difference between the platoons. Standard deviation calculations over periods including peak and off-peak demand periods could be similarly distorted; if the mean speeds in each period are different, the spread of speeds within each period could be smaller than the overall spread over both periods combined.

Of course, traffic is usually much more evenly distributed in time than this extreme example assumes, and the distribution of driver behaviors more random. In the interest of accumulating a sufficiently large sample of data, longer periods of observation are required to minimize sample noise. A tradeoff exists in optimum sample size (period) and the accumulation of a sufficient number of vehicles to generate a meaningful standard deviation value, not excessively prone to noise that might obscure a graphical trend.

For our evaluation of driver response, we required a nearly instantaneous measure of traffic turbulence, applicable to all vehicles, that can be used to indicate abrupt changes in potential hazard levels by considering only interactions between sufficiently proximate vehicles on the highway. In our analysis to follow, we capture a moving snapshot of the current level of turbulence in a traffic flow by a moving standard deviation metric over a period of 45 seconds, updated every 15 seconds. The 3:1 overlap between updates and periods of observation helps to reduce “end effects” in which the vehicles detected at the very start and end of each period are not compared with prior or subsequent periods, respectively. 45 seconds was found by trial and error to be the smallest possible period of observation that would always include a minimum of three vehicles on the three-lane sections of I-5 during light traffic (worst case). A 45 second period is actually too long to assure the possibility of interaction between all vehicles in each set, but was a necessary compromise in view of the need to acquire a sufficient number of vehicles. It was found to be adequate to emphasize speed differences between potentially interacting vehicles (independent of lane) and it provides a short enough period to graphically depict abrupt discontinuities in the traffic turbulence level – a key observation we seek as we attempt to observe immediate effects following the illumination of a driver warning message on the CMS. We distinguish our moving short-period measurements of standard deviation of speeds from standard deviation measured over long periods by referring to it as ***proximate standard deviation***.

2.4.2 Sight Distance Considerations in Fog

The safety affect of the reduction of sight distance during fog can be most directly accommodated by metrics based upon the time-distance-speed relationships between consecutive or at least proximate vehicles. Vehicle separation distance (and therefore gap) becomes irrelevant when it is less than the effective sight distance of a following driver, since they cannot react until they see a braking or stopped vehicle or some other hazard ahead.

The useful sight distance in fog depends on many factors; it cannot be measured definitively by any measurement instrument. The forward scatter visibility sensors used in the CAWS, and for our evaluation test sites also, measure an *extinction coefficient* σ with units of m^{-1} . Visibility distance is derived from σ and is considered to equivalent to a driver’s sight distance.

Bendix (33) pointed out that, for a fog bank of homogeneous composition, optical depth is proportional to the extinction coefficient and inversely proportional to the geometrical thickness of the fog layer.

$$\sigma = \frac{\delta}{\Delta z} \text{ (units of length}^{-1}\text{) , where } \delta = \text{optical depth (unitless)}$$

and Δz = thickness of fog layer (equivalent units of length)

He pointed out that for perceptual purposes, the relationship between optical depth δ and horizontal visibility VIS is probabilistic, with a best-fit trend line following a second order regression with $r^2 = 0.51$ and $r = 0.71$. However, the relationship used by most roadway transmissometers in the USA is

$$VIS = \frac{1}{\sigma} \ln \frac{1}{\varepsilon} \text{ (miles) , where } \varepsilon = \text{contrast threshold, commonly assumed to be 0.05.}$$

This relationship is generally accepted, and serves as the basis for FAA visibility distance calculations during daylight hours. This is referred to as Koschmieder's equation, with the coefficient K treated as equivalent to visibility distance by the QCMS visibility sensor for daylight conditions:

$$K = \frac{-\ln(0.05)}{\sigma} = \frac{3}{\sigma} \text{ (miles)}$$

Perceptual visibility is related to the extinction coefficient differently for day and night, and two relationships are used by the QCMS forward-scatter sensors (34) depending on the output of a separate day/night illumination sensor.

During night or low-light illumination conditions, visibility as perceived by a driver is effected by a large number of other factors including the illumination level of the taillights of the first vehicle, headlight backscatter, sun glare or opposing traffic headlight glare, condition of the vehicle windshield, and the type of fog. Under nighttime lighting conditions, Allard's Law determines the distance R at which a driver may be able to first see a preceding vehicle's taillights. The relationship is, unfortunately, not closed form in R :

$$E_T = I \frac{e^{-\sigma R}}{R^2}$$

where

R = night time visibility = K calculated using Allard's equation (miles)

I = Light intensity of target (tail lights), in candle power (cd).

According to Cobbs (35) as reported in (14), actual on-road light intensities vary from 6.4 for a normal 1990 brake lamp, to 150 for an ECE-compliant fog lamp (36). The QCMS uses a fixed conservative value, $I = 2$ cd, equivalent to their estimate of a minimum performance USA taillight (34).

E_T = Illumination threshold or minimum perceptible light intensity (lux).

The illumination (or illuminance) threshold varies according to the lighting condition. White and Jeffery (37) provided the data of Table 2.4.2.1 relating E_T to various outdoor lighting conditions.

Table 2.4.2.1 Illuminance Threshold E_T in Various Light Conditions.

Condition	E_T (lux)
Daylight	$1.0 * 10^{-3}$
Overcast day	$2.1 * 10^{-4}$
Very dark day	$4.5 * 10^{-5}$
Twilight	$2.0 * 10^{-6}$
Full moon	$4.2 * 10^{-7}$

The value used by the QCMS system is not specifically stated in the manual, but it appears from the numbers reported by the system that a value of $1.0 * 10^{-6}$ lux is used for the night visibility calculations. The transition is apparently abrupt; below some luminance level reported by the QCMS day/night sensor, the visibility distance calculation switches over from Koschmieder's equation to the minimum value between Koschmieder's equation and Allard's equation above, using $E_T = 1.0 * 10^{-6}$.

In the visibility distance numbers we report in the CAWS Evaluation System database and real time website, we also use the lesser of these values for night conditions as the effective sight distance of a driver in the development of the metrics below. This is justified in the QCMS manual by the statement that visibility distance as reported by the system is equivalent to the distance that a driver could see the tail lights of the vehicle in front of it (34). We recognize that this is at best, an average observation. We note, however, that even following the detailed discussion of this problem in (14), Hogema and Van der Horst ultimately justified the use of the simpler daytime Koschmieder's equation to estimate the driver's visual range during nighttime as well as day.

Note that transition between the visibility relationships between day and night can cause a discontinuity in the visibility distance for a constant extinction coefficient. This is resolved in the QCMS's as well as our

real-time CAWS evaluation web site by using the lesser of the distances calculated by each method during night illumination levels. This avoids an abrupt (zero order) discontinuity when the day/night sensor changes state, but still allows a first order discontinuity (change in the slope). The CAWS itself is susceptible to this discontinuity since visibility thresholds are established as ranges of visibility *distances* rather than extinction coefficients. The QCMS computer performs the distance calculation and sets user-programmable alarm flags based on the distance values, which are passed to the Signview computer and used to activate specific messages. In our time-history plots of visibility during fog events, this discontinuity sometimes becomes apparent. Therefore, to avoid the confusion that may be caused by this discontinuity during dawn and dusk analysis periods, we plot the raw extinction coefficient σ rather than calculated visibility distance as the measure of driver visibility.

2.4.3 Factoring Visibility Into Traffic Safety Metrics

In their evaluation of the DRIVE system (3), Hogema, Van der Horst and Nifterick presented data parametric with visibility range. But in their analysis of driver behavior in fog, they anticipated the need to consider visibility in a more direct way as a risk-enhancing factor (14). With the availability of individual vehicle records and local real-time visibility information, it is possible to construct metrics that consider both the fog-limited sight distance as well as the vehicle separation distance. In deriving such a metric optimized for the present evaluation, we start with prior concepts in the modeling of interactions between proximate vehicles in traffic. Heijer et. al. (38) studied real-time safety criteria for traffic, and developed a model based on three primary modes of behavior:

Anticipatory Mode – Generally associated with widely separated vehicles on a highway, permitting sufficient time for a driver to scan, estimate and plan a reasoned course of action. A decision to change lanes to avoid an upcoming slower vehicle would be an example of anticipatory behavior.

Pursuit Mode – A driver's attention is more narrowly focused on the immediately surrounding traffic, usually the vehicle directly in front. Limited response times do not permit the more reasoned behavior of of the anticipatory mode. Drivers react primarily to disturbances in traffic based on observation of proximate vehicles.

Emergency Maneuvering Mode – The driver perceives the need for immediate action to avoid a collision, but the time available is too short to allow any deliberations. As a practical matter, the option to change lanes or take some other evasive action to avoid a slowing or stopped vehicle or other obstruction ahead is small.

Under limited visibility conditions, anticipatory mode is all but ruled out due to lack of advance driver information. It should be noted that the functional (not ultimate) objective of the CAWS is to provide drivers with a substitute source of advance information on traffic conditions ahead beyond their site distance, which could help to restore anticipatory mode driver behavior. Whenever vehicles are in close

proximity, especially in a platoon or multi-lane group, the dominant mode of driver behavior prior to the occurrence of a traffic disturbance is pursuit mode. Once in emergency maneuvering mode, the laws of physics take over leaving the driver few behavioral (control) options other than applying the vehicle brakes.

Heijer et al (38) defined a safety criteria based on five types of disturbance which can be derived from inductive loop detector data. These were defined as “obviously dangerous (and therefore disturbing) events that must lead to either a braking maneuver or a lane changing maneuver to avoid a collision with a span of 3 s after the measurement of a passing vehicle”:

1. $TTC < 2$
2. Dangerous proximity 1: Vehicle speeds the same, and vehicle separation < 5 meters
3. Dangerous proximity 2: If first vehicle brakes strongly (6 m/s^2), the second vehicle cannot avoid a collision. A 1 second driver reaction time was assumed.
4. Overtaking on the wrong side, if executed at elevated speed ($> 80 \text{ km/h}$)
5. Simultaneous encroachment of two vehicles in adjacent lanes upon a third vehicle in one of those lanes, in such a way that they will want to overtake the third vehicle at the same moment

The occurrence of these events is calculated and averaged to a moving estimate of the frequency of disturbances. Events were counted in a binary sense; either the occurred or didn't occur; there was no linear or otherwise continuous range associated with each. They were counted as the number of occurrences in a moving window of 100 seconds. Typical values of this pseudo-real-time indicator were between .005 and .02 for most traffic, with peaks as high as .05 at the time of an accident. They proposed that this metric is not a predictor of accidents, but is a measure of relative safety.

One practical limitation of this metric is that, since it is a statistical measure, it requires a sufficiently long period of time to amass an adequate sample of events. It is also directly dependent upon traffic volume, since it is a measure of frequency of events per unit time.

However, we can build on this view of traffic safety and derive one or more measures of the severity of some subset of the “disturbance” events defined by Heijer, et al. Consider disturbances 1,2, and 3, all related to the following distance of a given vehicle. A continuous metric of relative traffic safety could be based on a scale of vehicle-following behavior ranging from anticipatory mode (minimum potential hazard) to emergency maneuver mode (maximum potential hazard), with the value degrading as reaction time and distance are reduced in pursuit mode. Following this approach, we considered various ways by which the relative safety of drivers could be more accurately inferred from knowledge of speed and

separation for individual vehicles, considering driver sight distance as well as vehicle separation. The objective was to generate a pseudo-instantaneous measurement that would be sensitive to small changes, in this case, the exposure of drivers to a CMS warning message. We do not suggest the use of such a metric as a predictor of accident rates, but only as a possible indicator for comparison of relative traffic safety, all other environmental factors held constant, grounded in the dynamics of the motion of each vehicle.

2.4.4 Rear-end collision risk and severity

In the CAWS study area, 1563 collisions occurred from January 1997 to December 2003. Of these 491 or 31.4% were classified in the CHP officer's report as "rear end" collisions, and 466 or 29.8% were classified as "hit object" (often debris from a prior accident). 61 of these all these accidents were classified as being in fog. For these, 34 or 55.7% were "rear end" collisions and 6 or 13.1% were "hit object" collisions. Table 2.4.4.1 shows the totals in each category. These cases, by definition, involve a vehicle approaching another vehicle or obstruction, and being forced to brake. It is probable that many of the "rollover", "sideswipe" and "other" classes were actually equivalent to rear end collisions, with slightly different damage outcomes. It is clear that the rear-end collision scenario represent a major descriptor of all accidents, and the majority of fog-related accidents. And usually, all vehicles involved in multi-car collisions in fog are "rear end" collisions. We note that the original legal motivation for the deployment of the CAWS was the reduction of catastrophic multi-car collisions in fog.

For the evaluation of a warning system primarily intended to reduce fog-bound collisions, it is therefore appropriate to focus on this class of collisions and construct metric based on the motion of successive vehicles in the same lane, as each vehicle transitions from anticipatory through pursuit mode, in the event of a potential traffic disturbance.

Table 2.4.4.1. CHP Classifications of Accidents in CAWS Study Area, 1993-2003.

Accidents	All-weather		In Fog	
Total	1563	100.00%	61	100.00%
Head On-A	11	0.70%	0	0.00%
Sideswipe-B	323	20.67%	13	21.31%
Rear End-C	491	31.41%	34	55.74%
Broadside-D	67	4.29%	2	3.28%
Hit Object-E	466	29.81%	8	13.11%
Overturn-F	102	6.53%	2	3.28%
Auto-Pedestrian-G	3	0.19%	0	0.00%
Other-H	98	6.27%	2	3.28%
Not Stated-<	2	0.13%	0	0.00%

In order to accommodate visibility-limited site distance, it is necessary to use a metric explicitly based on following distance, since following distances greater than the visibility sight distance do nothing to

enhance safety; a driver cannot decide to initiate braking until they can see the vehicle in front of them. Safe following distance calculations, such as those represented by the long-standard AASHTO (American Association of State Highway and Transportation Officials) chart of Figure 2.4.4.1, are based on speed-distance relationships, using assumed mean values of the coefficient of tire-to-pavement friction and

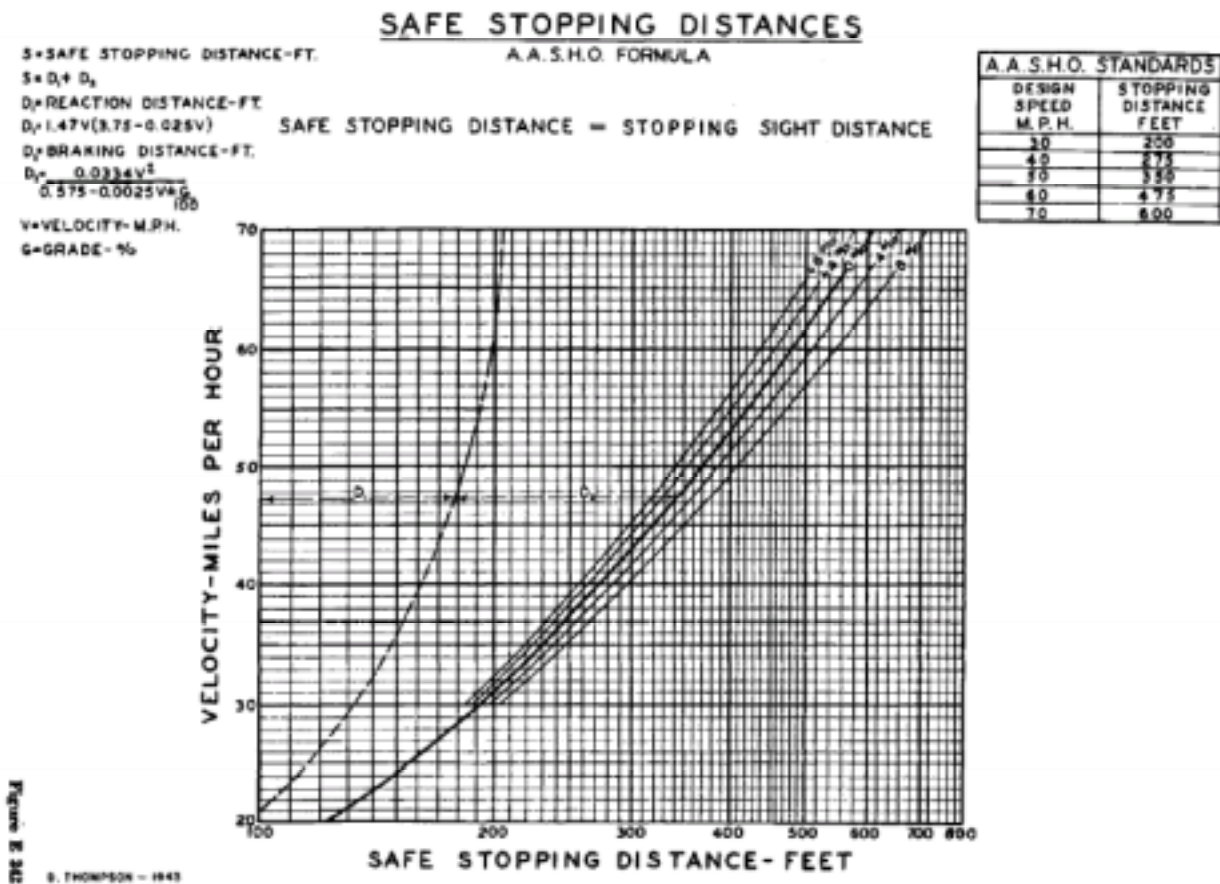

Figure 2.4.4.1. Safe Stopping Distance, AASHO (now ASASHTO) formula calculated by D. Thompson, 1943.

driver reaction time. It is possible using the same approach to calculate the speed of impact of the potential rear-end collision that would occur if the initial vehicle speed is exceeds the maximum speed permissible for the lesser of the following distance or the sight distance. Impact velocity has a physical relationship with both the severity of the potential crash, and the instantaneous level of danger assumed by the driver of each vehicle (danger considers both the potential consequences of a collision are the ability of the driver to avoid it if necessary). We will therefore use potential collision speed (PCS) as an

indicator of *relative* safety, useful for comparison of individual vehicles in a traffic flow. We assume that a driver will react to a disturbance ahead as soon as they can see it, and within a fixed reaction time, initiate braking and decelerate at the limit allowed by the coefficient of friction. If the potential collision speed is zero, this implies (subject to above assumptions) that the vehicle can stop completely prior to impacting the vehicle ahead of it. This would represent maximum safety and minimum risk of the collision. At the other extreme, a following distance or visibility distance less than the driver reaction distance represents the maximum collision severity and risk. In any given situation, the actual collision speed is dependent upon a range of possible emergency braking scenarios. The two extreme cases are explored below. Potential collision speed is not intended to be a proportional indicator of collision severity; this would be better approximated by the square of the PCS that is proportional to the kinetic energy release in the inelastic collision. It is also not intended to be a complete or proportional indicator of risk, which involves many other physical considerations. But as a supplement to speed and speed variance, it is expected to be a useful surrogate indicator of the relative level of “danger” in a traffic flow that includes provision for visibility-limited situations. However, until a definitive relationship has been established between collision rate and PCS based on long-term collision data, we must leave any such inference at the discretion of the reader.

We consider the dynamic relationship between consecutive vehicles in the same lane, and consider two extremal accident scenarios. The first scenario may be generally associated with the reaction distance D_1 curve in Figure 2.4.4.1, and second scenario includes both D_1 and the braking distance D_2 .

2.4.4.1 Scenario 1 – Isolated rear-end collision, or first collision in a multi-car chain collision

This scenario applies to the first vehicle behind another vehicle that brakes normally to a stop. The lead vehicle brakes aggressively but within the limits of the time-to-pavement coefficient of friction, either to decrease speed or to come to a stop. The following distance is inadequate for the trailing vehicle to brake aggressively to a stop without impacting the lead vehicle. The vehicle does not abruptly change lanes during the braking maneuver. This scenario is the most forgiving extreme case, allowing the shortest following distance or sight distance.

Regarding the no-lane-change assumption for this scenario: While an evasive lane change may be possible, the greatly reduced lateral control of a vehicle during maximum braking makes this unlikely to execute safely. If maximum braking is not actually required, then there is no advantage to an evasive lane change in this scenario since there would be no collision if the driver stayed in the original lane. If an evasive action lane change occurs, the scenario becomes different, possibly more severe for traffic in the destination lane.

Defining terms, the lead vehicle, denoted vehicle $i-1$, initiates a stop and maintains its maximum possible deceleration (braking) rate until it comes to a stop, without impacting any object in its path. The driver of

the following vehicle, denoted vehicle i , reacts as quickly as possible, and decelerates at its maximum possible deceleration rate until it either comes to a stop or impacts the lead vehicle.

Structural assumptions:

- Both vehicles are initially traveling at the same speed, in the same direction, in the same lane.
- Constant coefficient of friction, vehicle tires-to-roadway $k_{\text{fric}} = 0.5$, which is typical of modern automobile tires in good condition on a moist but clean freeway (concrete or asphalt) surface. Wet but not raining. Moisture layer < 1 mm (39). We note that the effective value of k_{fric} can vary widely, from less than 0.05 for icy surfaces, to over 1.0 for tires with very soft/gummy compounds (such as racing tires) on dry pavement. Large trucks are especially limited due to the articulated geometry of the tractor-trailer, and since all wheels do not usually brake evenly, limiting the net braking force to the first wheel to lock up (except for trucks equipped with all-wheel ABS). The use of $k_{\text{fric}} = 0.5$ is a reasonable average for all vehicles, considering that our objective is to specify a consistent metric related to the dynamics of vehicle stopping, but not necessarily a predictor of the exact stopping distance or speed for a particular vehicle.
- Both vehicles decelerate at the same maximum braking rate, just below the coefficient of friction, but do not enter a skid. While this is theoretically true, and may be practically true for newer vehicles with ABS (Automatic Braking Systems), the actual situation during braking is often that of an uncontrolled skid, during which the effective coefficient of friction drops to well below the value assumed above, and lateral control is lost.
- Driver total reaction time = $t_{\text{react}} = 0.75$ second. This includes perception time, decision time, time required to move the driver's foot from the accelerator to the brake pedal and depress the brake, and any mechanical or hydraulic lags in the response of vehicle braking system. This number varies widely, and has been reported as low as 0.3 seconds for recognition time (40) and as high as 2.0 for complete recognition to braking action (41). We elect to use an optimistic value of .75 in our analysis, so that when the metric achieves a maximum possible value equal to the speed of the vehicle, it is a nearly certain predictor of an impending collision given a traffic disturbance.

When the following distance $x_{\text{separation},i}$ is less than the sight distance $x_{\text{vis},i}$ we can assume that vehicle i starts to brake t_{react} after vehicle $i - 1$ starts to brake and its brake lights come on. This provides a starting point for both deceleration calculations, with both vehicles assumed to be initially traveling the same speed. However, if $x_{\text{separation},i} > x_{\text{vis},i}$ then vehicle $i - 1$ could have been braking for some time before vehicle i can see the taillights and start to react. The speed of the lead vehicle could therefore be anything from its initial speed $v_{0,i-1}$ to zero depending on when it can first be seen by the driver of the trail

vehicle i . The most that can be stated is that in the best case condition in which $x_{separation,i} < x_{vis,i}$ the driver of the trail vehicle could begin to react as soon as the lead vehicle start to brake. In the worst case, the lead vehicle has come to a complete stop (either by braking or collision with the vehicle ahead of it) before it can be seen by the driver of the trail vehicle. This latter case is the Scenario 2, to be discussed next.

Assuming the best case $x_{separation,i} < x_{vis,i}$, vehicle i starts to brake t_{react} after vehicle $i-1$ starts to brake, and both vehicles decelerate at the limits of the tire-to-pavement coefficient of friction. The stopping time for vehicle i may be divided into two periods: reaction time t_{react} and braking time t_{brake} . During the reaction time, the vehicle continues at its initial velocity, $v_{0,i}$ for a distance $x_{react,i} = t_{react} v_{0,i}$. The vehicle then decelerates at a rate of $k_{fric} g$ where g = acceleration of gravity, 32.2 ft/sec² (9.8 m/s²). If $x_{separation,i} > x_{react}$, since the trail vehicle i can see the lead vehicle $i-1$ start to brake, and it will initiate braking vehicle t_{react} after vehicle $i-1$ starts to brake, it will initiate braking before traveling the separation distance $x_{separation,i}$ between the vehicles. There will be no collision since both vehicle will follow the same deceleration curve. Vehicle i will reduce its speed to the final speed (or full stop) of vehicle $i-1$ a distance $x_{separation,i} - x_{react}$ behind vehicle $i-1$. If, however, $x_{separation,i} < x_{react}$ then a collision will occur. The differential velocity between the two vehicles at the moment of impact is found by determining the time of the collision from the overlaid position-vs-time plots of both vehicles, substituting this time into the velocity vs time relationship of each vehicle, and taking the difference:

This represents the most benign traffic situation: identical vehicles in a platoon braking uniformly with only the driver reaction time determining the minimum safe vehicle separation. Visibility is not a limiting factor.

2.4.4.2 Scenario 2 - Collision with stopped vehicle, or later collisions in a multi-car chain collision

This scenario applies to the later vehicles involved in a multi-car chain collision. A stationary obstruction or existing pile-up ahead becomes suddenly visible to each successive driver at a distance too short to brake to a complete stop. The mass of the trailing vehicle prohibits an abrupt lane change to avoid the blockage, or the blockage extends across multiple lanes, preventing evasive action by a lane change. This scenario is the least-forgiving extreme case, requiring the longest safe following distance or sight distance. It is, however, the situation that exists for all but the first collision pair in a multi-car pileup in fog.

The lead vehicle, denoted vehicle $i+1$, impacts a stopped vehicle or previous accident on the roadway, coming to a complete stop instantly. We focus though, on the situation faced by the third or later vehicle

involved in a linear chain collision, or the unexpected encounter of a driver with a stationary object in the roadway. The driver of the following vehicle, denoted vehicle *i*, reacts as quickly as possible, and decelerates at the maximum possible braking rate until it either comes to a stop or impacts vehicle *i*+1.

Structural assumptions, (same as Scenario 1, but Assumption 3 pertains only to vehicle *i*):

- Both vehicles are initially traveling at the same speed, in the same direction, in the same lane.
- Constant coefficient of friction, vehicle tires-to-roadway $k_{fric} = 0.5$.
- Vehicle *i* decelerates at the maximum braking rate, just below the coefficient of friction, but do not enter a skid.
- Driver total reaction time = $t_{react} = 0.75$ second.

In this scenario, vehicle *i* must come to a complete stop within its following distance to avoid a collision. If $x_{separation,i} < x_{react,i}$ then a collision will occur with an impact velocity of $v_{0,i}$. This is a far more demanding scenario than that of Scenario 1, requiring that the separation distance $x_{separation,i} > x_{react,i} + x_{brake}$ in order to avoid a collision. After initiation of braking, the remaining distance between the two vehicles determines the velocity at the time of impact. The relationship between the impact velocity and the required separation distance is given by equation (1) below.

$$v_{impact,i} = \begin{cases} v_{0,i} \sqrt{1 - \frac{\min\{x_{vis}, x_{separation,i}\} - x_{react,i}}{x_{brake,i}}} , & \min\{x_{vis}, x_{separation,i}\} \geq x_{react,i} \\ v_{0,i} , & \min\{x_{vis}, x_{separation,i}\} < x_{react,i} \end{cases} \quad (1)$$

$v_{0,i}$ = initial velocity of following vehicle

x_{vis} = visibility site distance

$x_{react,i} = t_{react} v_{0,i}$ = reaction distance of vehicle *i*, t_{react} = driver reaction time

$x_{separation,i} = (t_{0,i} - t_{0,i-1}) v_{0,i-1}$ = separation between vehicle *i* and *i* - 1

$t_{0,i}$ and $t_{0,i-1}$ are the detection times for each vehicle

$$x_{brake,i} = \frac{v_{0,i}^2}{2gk_{friction}} = \text{braking distance of vehicle } i$$

The relationship between the impact velocity and the initial separation distance is shown graphically in Figure 2.4.4.2.

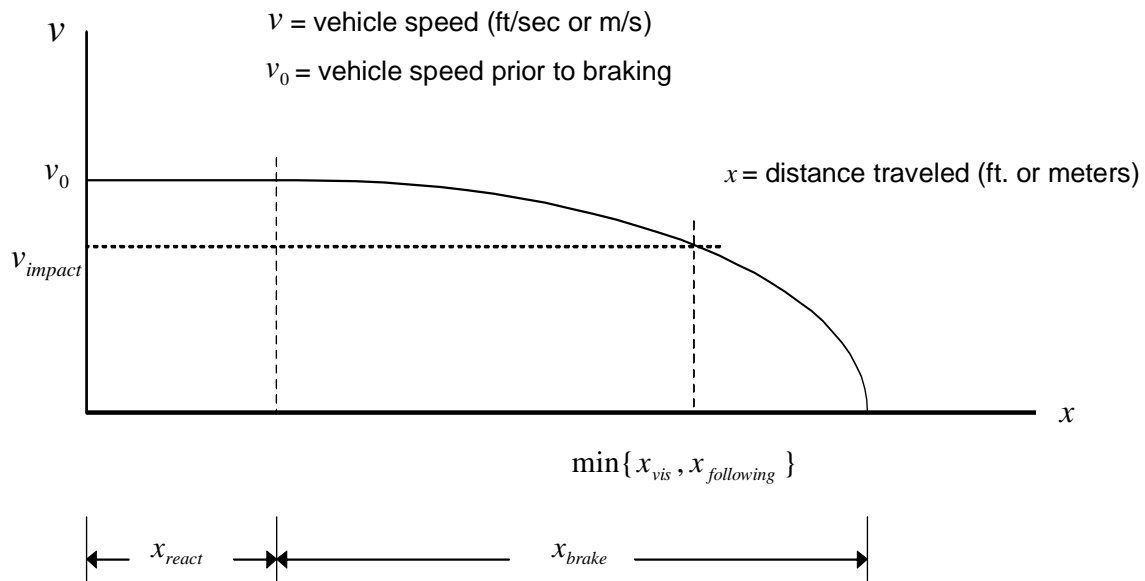

Figure 2.4.4.2. Impact velocity v.s. total car following distance for Scenario 2: Multi-car Collision.

During conditions of limited visibility, the driver of vehicle i cannot react until they can see the brake lights of the preceding vehicle or the obstruction ahead. Following distances greater than the sight distance x_{vis} add no incremental margin of safety. For this reason, it is necessary to use the smaller of the following distance $x_{separation}$ and the sight distance x_{vis} to determine the maximum initial velocity at which the vehicle is capable of stopping to avoid a stopped vehicle or collision ahead.

The condition necessary to avoid a collision is therefore

$$\min(x_{separation,i}, x_{vis}) \geq x_{brake,i} + x_{react} = \frac{v_{0,i}^2}{2gk_{friction}} + t_{react} v_{0,i}$$

From our examination of reports of most recent nationally reported multi-car collisions in fog, the latter scenario is applicable both to the trigger event and to the subsequent collisions: The first collision most often involves a collision between a large truck and a slow or stopped smaller vehicle. Subsequent collisions involve vehicles colliding with the growing pile-up. For this reason, we have elected to use the potential collision speed (PCS) in this extreme scenario as a continuous measure under limited visibility conditions.

A possibly more relevant version of this metric might be the square of the potential impact velocity, since it is proportional to the kinetic energy release in the collision, and therefore is a mass-normalized indicator of the severity of the collision. We elected to not use $v_{impact,i}^2$ after a number of trials using it, since the

square effect tended to accentuate the higher values in a way that tended to obscure the more subtle changes for less extreme values. This was an arbitrary decision based on graphics legibility.

The inference is that this “real-time” metric can be used to help reveal changes in driver behavior indicative of positive or negative changes in the relative safety of the traffic. As with other evaluations, we leave this interpretation to the discretion of the reader.

2.5 Description of Data Collected

For each vehicle detected at the two “before” and two “after” sites, we measure and record the following raw values:

1. Lane of detection. (Lane 1 = fast lane, Lane 3 = slow lane.)
2. Vehicle time of arrival, referenced to the moment of inductive detection at the second loop of the duplex loop pair. Measured with precision of .000020 seconds, and recorded with precision of 0.010 seconds, but considered accurate to only 0.02 seconds due to ambiguity in the relationship between the point of inductive detection and the actual front end of the vehicle, and the sample period of the loop detector card.
3. Time of flight between duplex loop detectors. Measured with time resolution of 0.000020 second but considered accurate to only 0.04 seconds due to ambiguity in the relationship between the point of inductive detection and the actual front end of the vehicle, and the finite sampling period of the loop detector card.
4. Lane of detection
5. (For sites equipped with visibility sensors) the current visibility reported as the extinction coefficient (m^{-1}).

After these raw measurements from the field data acquisition systems are transferred to the central server and recorded in the central database, the following metrics are calculated:

1. Vehicle occupancy time above each of the two duplex loops in the lane. Measured and recorded with precision of .000020 seconds, but considered accurate to only 0.04 seconds due to ambiguity in the relationship between the point of inductive detection and the actual front end of the vehicle, and the sample period of the loop detector card.

2. Vehicle speed derived from the time of flight between duplex loop detectors with known separation. Recorded to a precision of 0.1 mph but considered accurate on to 1 mph due to precision of time measurements limited by loop detectors, as described above.
3. Vehicle length derived from the product of the vehicle speed and the average of the two occupancy time measurements above each of the duplex loops in the lane. Recorded with precision of 0.1 foot, but considered accurate to only 2 feet due to loop detector limitations described above.
4. Vehicle headway, calculated as the time difference between the detection of a vehicle and the vehicle the preceded it, assuming that the preceding vehicle maintains a constant speed during this period (isoveloxic assumption). Recorded with precision of 0.1 foot, but considered accurate to only 2 feet due to loop detector limitations described above.
5. Vehicle separation, calculated by subtracting the length of the preceding vehicle from the present vehicle headway. Recorded with precision of 0.1 foot, but considered accurate to only 3 feet due to loop detector limitations described above.

Space on the time-history plots of traffic events to follow limit the number of real-time metrics to those few, which we feel best illustrate changes in driver behavior indicative of relative safety. In later discussion we consider other indicators that were not appropriate to add to the already-busy plots. As discussed previously, we use a reasonably short observation period for the “real-time” plots of event time histories. In addition to the relevancy considerations described previously, the use of a short moving period of observation avoid blurring abrupt transients in the traffic conditions which can reveal small levels of driver reaction to the CMS warning message.

Over the course of each event, we calculate the following time histories:

Moving average vehicle speed is calculated and reported every 15 seconds, based on the 45 seconds preceding the time of reporting. It is calculated for each lane, and the site result is calculated as the lane-volume-weighted average. Values on the plots labeled as “before-CMS” and “after-CMS” are the traffic volume-weighted average of the results from the two “before” sites or the two “after” sites respectively. Units are miles per hour.

Proximate speed standard deviation with respect to the mean is calculated and reported every 15 seconds, based on the 45 seconds preceding the time of reporting. It is calculated for each lane, and the site result is calculated as the lane-volume-weighted average. Values on the plots labeled as “before-CMS” and “after-CMS” are the traffic volume-weighted average of the results from the two “before” sites or the two “after” sites respectively. Units are miles per hour.

Potential Collision Speed (PCS) is calculated based on the velocity and frontal separation of each vehicle. It is reported updated every 15 seconds based on the 45 seconds preceding the time of reporting. It is calculated for all vehicles arriving in any lane during the 45 second window. Values on the plots labeled as “before-CMS” (BCMS) and “after-CMS” (ACMS) are the traffic volume-weighted average of the results from the two “before” sites or the two “after” sites respectively. Units are in mph. The maximum possible value of PCS is the individual vehicle speed. Therefore, the maximum possible value of the moving average PCS is approximately the mean traffic speed determined over this same 45 second window.

The average real-time Traffic Volume is also reported in vehicles/minute. It is reported as the total flow rate in all three lanes at each site in vehicles per minute. It is measured over the period of 45 seconds preceding each 15-second update. It is reported as *vehicles per minute* in order to scale it to fit within the range of the common ordinate on the plots. A single measurement is reported to represent average volume at all sites, which is the vehicle-count-weighted average from the before-CMS and after-CMS sites (total of four sites). This aggregation is justified because we have observed very little difference in traffic volume other than transport lag between the sites, since they lie in close proximity on the same highway, with only one opportunity to exit or enter the highway between the before-CMS and after-CMS points of observation. This reduced the clutter on the busy time-history plots. Averaging was done for display purposes only, not for normalization of the metrics above.

The current Visibility reading from the Before-CMS and After-CMS visibility sensors are also reported as extinction coefficients (ft^{-1}). Higher values imply denser fog and worse visibility. The translation between daylight visibility distance in feet and the extinction coefficient was described in Subsection 2.4.2. Three visibility thresholds are of particular relevance since they represent the CAWS message trigger levels (QCMS alarm settings) in effect during the first year (2003-04) of the study:

Table 2.4.4.1. Visibility distances and corresponding extinction coefficients, alarm levels and CAWS warning messages.

Visibility Distance (ft.)	Extinction Coefficient (ft^{-1})	Alarms level	CMS Message* (2003 – 2004)	CMS Message* (2004 – 2005)
500	31.68	1 (200<.< 500 ft.)	DENSE FOG AHEAD, ADVISE 45 MPH	DENSE FOG AHEAD, ADVISE 45 MPH
200	79.2	2 (100<.<200 ft)	DENSE FOG AHEAD, ADVISE 30 MPH	DENSE FOG AHEAD, ADVISE 45 MPH
100	158.4	3 (<.100 ft.)	<blank>**	DENSE FOG AHEAD, ADVISE 45 MPH

* Messages changed in summer of 2004 prior to the 2004-05 fog season.

** No message was displayed when visibility drops below 100 ft. due to an error in the Signview software.

Our data connections to the QCMS visibility sensors update every 30 seconds. The CAWS system used a visibility polling period that was initially to 5 minutes. We understand that this was changed by District staff to 15 minutes in order to decrease the density of routine entries in the weather log files.

Inadvertently, this change also seems to have increased the system response lag time due to the lengthened polling period.

The CMS Warning Message displayed on the CMS over the course of an event is indicated by a light blue line that assumes three levels, indicative of alarm levels 1, 2 and no alarm (no messages). The messages operative during most of the fog season of 2003-04 are shown in Table 2.4.4.1.

2.5.1 Event Case Studies

In subsection 2.7 we present selected time-history plots for events in which the CAWS CMS 1 activated in response to fog, traffic, wind or combinations thereof. We feel that this graphical approach provides a unique perspective on relative affect that supplements and goes beyond the tabular data that follow the plots for each event. From the inspection of the subsequent event plots, it is possible to observe in “re-play real-time”, the reaction of drivers:

1. On the sections of roadway immediately prior to and following exposure to a CMS advisory message. In this case, we seek to find a difference between these metrics measure at the two locations, which might imply that the drivers have responded to the advisory in a positive way.
2. On the same section of road comparing the time period immediately before and immediately after the CMS is activated. In this case, we seek to find a discontinuity in the above metrics that indicates a positive effect.

We also calculate cumulative values of each metric over periods during which a particular combination of conditions and/or interventions was present, such as foggy periods during which a CMS message was displayed as opposed to foggy periods in which a message was not displayed (due to system malfunction or programming).

2.6 Cited References

1. Hauer, E. "Observational Before-After Studies in Road Safety," Pergamon Press, Elsevier Science Ltd., Oxford, U.K. 1997.
2. Cochran, W.G. "Planning and analysis of observational studies." Edited by Moses, L.E. and Nosteller, F. John Wiley & Sons, 1983.
3. Hogema, J.H., Van der Horst, A.R.A., Van Nifterick, W., Stoop, J. "Evaluation of an automatic fog-warning system." J. Traffic Engineering and Control, 37, No. 11, p 629-632, Nov. 1996.
4. Martin, P.T., Perrin, J., Cottrell, W., Coleman, B. "Adverse Visibility Information System Evaluation (ADVISE)," Final Report to the Utah Dept. of Transportation, Research Division, UTL-0300-28/02, June 2002.
5. Garber, N.J. Gadiraju, R. "Factors Affecting Speed Variance and Its Influence on Accidents," Transportation Research Record 1213, Transportation Research Board, National Academy of Sciences, Washington DC., pp. 64-71, 1989.
6. George, L., Hofstetter, Wagner, D. "Variable Message Fog Hazard Warning Signs to Control Vehicle Operating Characteristics," Report No. FHWA/OR-79/3, Oregon DOT, Federal Highways Administration, Washington, DC., 1979.
7. Shepard, F. "Traffic Flow Evaluation of Pavement Inset Lights for Use During Fog," Report No. VHTRC 78-R25, Virginia Highway and Transportation Research Council, 1977.
8. Shepard, F. and others, "Synthesis of Highway Practice 228, Reduced Visibility Due to Fog on the Highway," National Cooperative Highway Research Program, Transportation Research Board, National Academy Press, Washington, DC., 1996.
9. Hirst, W.M., Mountain, L.J., Maher, M.J., "Sources of error in road safety scheme evaluation: a quantified comparison of current methods," Accident Analysis and Prevention, accepted for publication May 23, 2003.
10. Perrin, J., Martin, P., Coleman, B., Hansen, B. "Testing the Adverse Visibility Information System Evaluation (ADVISE)," University of Utah Draft preprint of paper submitted June 2000 for publication in the Transportation Research Record, Transportation Research Board, National Academy of Sciences, Washington DC.
11. Elvik, R. Assessing the validity of road safety evaluation studies by analyzing causal chains," Accident Analysis and Prevention, V.35, 2003, pp.741-748.
12. Golob, TF, Recker, WW, Alvarez, VM, "Freeway safety as a function of traffic flow," Accident Analysis & Prevention, article in press September, 2003.
13. Sivak, M. "How common sense fails us on the road; contribution of bounded rationality to the annual worldwide toll of one million fatalities," Transportation Research, Part F- Traffic Psychology and Behavior, V 5, pp. 259-269, 2002.
14. Hogema, J.H., Van der Horst, A.R.A, "Driving Behaviour in Fog: Analysis of Inductive Loop Data," TNO Report TM 1994 C-6. Ministry of Transport, Public Works, and Water Management, Rijkswaterstaat, P.O. Box 1031 3000 BA Rotterdam, 1994.
15. Jorgensen, F. Wentzel-Larsen, T. "Optimal use of warning signs in traffic," Accident Analysis and Prevention, V. 31, No. 5, pp 729-738, Nov 1999.
16. Darell, J.E.P., Johnston, J.E., Transeau, T.E., and Wiley, C.C "What About Speed Limits?" Proc. Institute of Traffic Engineers, 1950, p. 42.
17. Canadian Ministry of Transport and Communications, "Speed and Accidents: A Preliminary Report." Ministry of Transport and Communications, Ontario, Canada, 1974.
18. Solomon, D., "Accidents on Main Rural Highways Related to Speed, Driver, and Vehicle," U.S. Dept of Transportation Federal Highway Administration, Washington DC, July 1964, reprinted 1974.
19. Pisarski, AE, "Deep-Six 55." Reason Foundation, Vol. 17. No. 6, Nov. 1986, pp. 32-35.
20. US Dept. of Transportation, Federal Highway Administration, "Synthesis of Safety Research related to Speed," Publication No. FHWA-RD-98-154, August, 2002.
21. National Cooperative Highway Research Project (NCHRP) Synthesis, Report No. 228 (first release). National Academy of Science Transportation Research Board, 1967.

-
22. Davis, G.A., "Is the claim that 'variance kills' an ecological fallacy?" *Accident Analysis and Prevention*, V 34, No. 3, pp. 343-346, May 2002.
 23. Hauer, E. "Cause and Effect in Observational Cross-section Studies On Road Safety," available on-line at <http://ca.geocities.com/hauer@rogers.com/download.htm> Feb. 2005.
 24. Hauer, E. "Speed and Crash Risk: An Opinion," Report 04/02 of the Royal Automobile Club of Victoria May 2004.
 25. Hauer, E., Review comments submitted as a member of the CAWS Evaluation External Panel of Experts, August, 2005.
 26. *Traffic Control Systems Handbook*, US Dept. of Transportation Federal Highway Administration, FHWA-IP-85-11, 1985 and FHWA-SA-95-032 1998.
 27. Sullivan, EC "Estimating accident benefits of reduced freeway congestion," *Journal of Transportation Engineering*, V 116, pp. 167-180, 1990.
 28. Van der Horst, A.R.A., Hogema, J. "Time-To_Collision and Collision Avoidance Systems," Proc. 6th ICTCT Workshop Safety Evaluation of Traffic Systems; Traffic Conflicts and other Measures," Salzburg, pp. 109-121, Oct. 1993. (available from TNO Institute for Human Factors, P.O. Box 23, 3769 ZG Soesterberg, Netherlands.)
 29. Minderhoud, M.M., Bovy, P.H., "Extended time-to-collision measures for road traffic safety assessment," *Accident Analysis and Prevention*, V 33(1), Jan 2001, pp. 89-97.
 30. Hayward, J.Ch. "Near miss determination through use of a scale of danger." Report No. TTSC 7115, The Pennsylvania State University, PA, USA. From reference in (29).
 31. Hirst, S., Graham, R. "The format and presentation of collision warnings," in *Ergonomics and safety of intelligent driver Interfaces*, Noy, Y.I. editor, 1997.
 32. Van der Horst, A.R.A. Personal interview, Washington D.C., January 2005.
 33. Bendix, J. "A case study on the determination of fog optical depth and liquid water path using AVHRR data and relationships to fog liquid water content and horizontal visibility," *Int. Journal Remote Sensing*, Vol. 16, No. 3, pp. 515-530, 1995.
 34. Qualimetrics Inc. (now All Weather Inc.), "Caltrans Meteorological System Manual, Section 1. pp.2-3, Caltrans Contract No. 10-442204, All Weather Inc., Sacramento California, 1996.
 35. Cobbs, J. "Roadside survey of vehicle lighting 1998," TRRL Digest RR290.
 36. ECE "Agreement concerning the adoption of uniform conditions of approval and reciprocal recognition of approval for motor vehicle equipment and parts," Addendum 6, Supplement 3, Geneva, FRS, July 2 1987.
 37. White, M.E., Jeffery, D.J. "Some aspects of motorway traffic behavior in fog. Transport and Road Research Laboratory, TRRL laboratory report 958, Crowthorne, UK.
 38. Heijer, T., Wiersma, E., Polak, P.H. "Proposed Safety Criteria for Traffic Control on Motorways," *Safety Science* Vol. 26 No. 1 / 2, Pergamon Press, pp. 141-154, 1997.
 39. Robert Bosch GmbH, "Automotive Handbook, 5th ed." p. 343, 2000
 40. Naatanen, R., Summala, H. "Road-user behavior and traffic accidents," North Holland/American Elsevier, New York, 1976, Ch. 4.
 41. "Vehicle Stopping Distance and Time," <http://www.csgnetwork.com/stopdistinfo.html> 2005.

2.7 Data Presentation and Analysis

We report here data from selected event case histories, with all quantities plotted with respect to time, as well as in tabular form. The complete set of 87 major event cases histories are contained in the CD appendix to this section of the report.

For fog-related activations, CMS 1, which we were monitoring, is actuated solely by the Mathews Road Weather Station (WS1), which is the same as our evaluation monitoring Site 2. The data set covers Fall 2003 through Spring 2005, including the complete fog seasons 2003-04 and 2004-05.

During the first complete fog season (2003-04), the CAWS was configured to automatically display two warning messages: "DENSE FOG AHEAD, ADVISE 45 MPH" when fog-visibility dropped below 500 ft., and "DENSE FOG AHEAD, ADVISE 30 MPH" when fog-visibility was between 100 and 200 ft. When fog-visibility dropped below 100 ft., no message is displayed.

During the second complete fog season (2004-05), the CAWS was configured to automatically display a single warning message for all fog visibilities less than 500 ft.: "DENSE FOG AHEAD, ADVISE 45 MPH".

Only fog-related visibility is used to actuate CAWS, which requires that relative humidity (RH) be greater than 75%. No actuation occurs if RH is less than 75% regardless of the visibility reading.

Speed-related actuations of CMS 1 were controlled by speed measurements from the Mathews road weather stations/speed monitoring site, and traffic monitoring sites 1B, 1C 2A, and 2B. These stations are immediately down-road of the CMS at distances of 0.5 and 1.1 miles respectively. Three messages are possible: When speeds below 35 mph are detected in at least one lane, but no lanes exceed 50 mph, SLOW TRAFFIC AHEAD is displayed. When speeds below 11 mph but no lanes over 50 mph are detected, STOPPED TRAFFIC AHEAD is displayed. And the CMS immediately prior to the one displaying the warning message will display "HIGHWAY ADVISORY AHEAD" as an advanced notice to drivers to watch for the actual warning message on the following CMS.

Traffic warning messages on CMS 1 can be triggered by the following CAWS speed monitoring sites:

Warning messages: 1A (Mathews Road), 1B (El Dorado OC), 1C (Roth Road), 2A and 2B

Highway advisory ahead messages: 2C, 2D, 3A, 3B

The locations of these sites are shown in Figure 2.5.1.1, a map of the CAWS study area in which we have overlaid the connection paths that we have determined to be operative from analysis of the Signview and TMS software (more on this in the Operational Assessment section of this report).

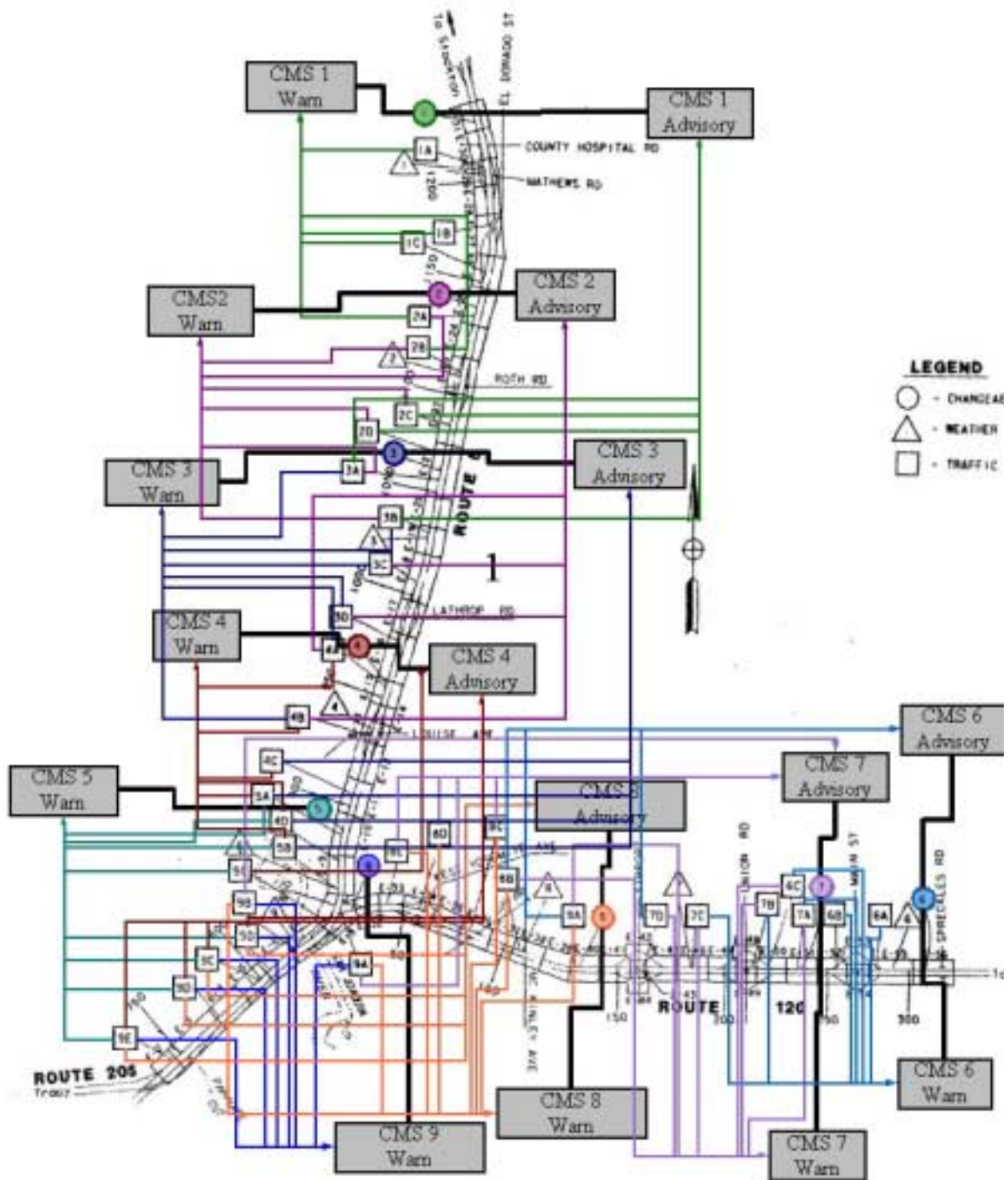

Figure 2.5.1.1. Current activation mapping between speed monitoring sites and CMSs.

A considerable lag occurs between the time that the conditions for detection are met and the time that the corresponding message(s) are displayed, usually between 3 and 9 minutes, averaging slightly over 7 minutes over all transitions, as discussed in the Operational Assessment section of this report. These delays can be clearly seen in the time histories.

Two plots and two tables are presented for each event. The content and interpretation of each are described below:

1. Short-period moving average plot

The abscissa is clock time in 24-hour format. BCMS = 'Before the CMS'. ACMS = 'After the CMS'. Readings are reported as the volume-weighted average of the two BCMS and the two ACMS sites, respectively. Centered 45-second moving averages are used to establish trend lines through the data cloud (individual points are suppressed for clarity) for PCS and mean speed on the lower part of the plot, and proximate standard deviation of speed on an expanded scale in the upper part of the plot, with the scale on the right.

Visibility is reported on the upper part of the plot. An equivalent visibility distance scale is provided on the left. Dashed lines indicate the visibility thresholds for CMS messages at 500, 200 and 100 feet. Visibility is plotted for 30-second intervals measured at the second BCMS (French Camp Slough) site in green and at the first ACMS (Mathews Road) site in violet. Visibility is reported as the extinction coefficient, although visibility distance lines have been overlaid and scaled on the left of the upper part of the plots. Larger values indicate denser fog. As discussed previously, the relationship between the extinction coefficient and actual practical driver visibility is highly dependent on other factors, including the ambient illumination level and target contrast, but the approximate relationship is given in Table 2.4.4.1 for average daylight conditions on the highway.

The state of the warning message is indicated by a light blue line in the upper part of the plot: 0 ⇒ no message, 4 ⇒ ADVISE 45 MPH, 6 ⇒ ADVISE 30 MPH from Table 2.4.4.1 unless otherwise noted.

Traffic volume is shown in yellow on the lower part of all plots, with the scale on the left in vehicles per minute. A single yellow trace indicates the average traffic volume at all sites, since volumes differed very little between sites.

For mean speed, proximate speed standard deviation, and PCS, BCMS measurements are in red and ACMS measurements are in blue. Individual data points are suppressed for clarity; only windowed averages are shown.

For alignment purposes, note that vehicles detected at the BCMS sites are detected at the ACMS sites 105 seconds later at 70 mph, or on average for all speeds, approximately two minutes later. The CMS is controlled by the visibility sensor at the first ACMS site.

Due to the scatter in all data, trend lines are overlaid on each data type to assist in before-CMS and after-CMS comparisons. For all trend lines, we use traffic-volume-weighted 9-cycle centered moving averages. Since each cycle is 15 seconds, the trend lines may be considered to be averages over the data one minute prior to and one minute following any point on the trend line. The trend lines are therefore subject to a smoothing lag of approximately two minutes maximum and one-minute mean. The choice of centered moving averages was elected so that inflections in the trend line are correctly aligned with possible causal events, such as a change in the CMS message.

2. Differential moving average plot

To better examine the small differences between data from the before and after sites, the differences between the data from each site, time-aligned, are plotted. This presentation format makes clear the relative differences between mean speeds, speed standard deviations, and PCS, between the two before-CMS and the two after-CMS sites. Other than the change in the method of presentation, no additional information is provided by these plots compared with the short-period moving average plots.

The state of the warning message is indicated by a light blue line at the bottom of the plot: 0 \Rightarrow no message, 20 \Rightarrow ADVISE 45 MPH, 30 \Rightarrow ADVISE 30 MPH.

3. Constant-message average table

This table is derived from the same data of the previous short-period moving average and differential moving average plots, except that it reports the average of each metric over the entirety of each period that a particular CMS message was displayed, up to one hour in duration. From these tables, it is easier to discern the average reaction of drivers before and after viewing a message, over the period in which each message level was displayed.

The table also includes the percent difference between the after-CMS sites and the before-CMS sites, for each metric measured over the constant message period. Positive values represent a larger value of each metric (mean speed, speed standard deviation, or PCS) at the after-CMS site compared with the before-CMS site.

On these tables and the transient response tables, PCS is reported normalized to the vehicle speed as a percentage. A PCS value equal to the vehicle speed would be 100%. A 0 % would imply that all vehicles were maintaining a PCS of zero mph. Since period means are reported, a 100% mean value was reported during any constant period, this would imply that all vehicles were driving with following distances so short that they could not avoid a rear-end collision in the event of almost any type of traffic disturbance.

This presentation supports numeric comparison of driver behavior over the duration of each message period. While the long duration of the examination periods helps to generate well-averaged numeric

results, other factors, especially visibility, can vary significantly between the sites. Therefore, conclusions drawn from this data presentation must be considered against the direct influence of local visibility on driver behavior at each site.

4. Transient response table

This table presents the differential response of drivers immediately prior to and after a message is displayed as an indicator of response under nearly invariant external conditions. Metrics are normalized between sites to focus on transient effects. For example, the average mean speed is measured at the before-CMS and after-CMS sites over the 5-minute periods prior to and after activation of a CMS. The values from the after-CMS site are divided by the values from the before-CMS site. One is subtracted from this value, and the result is multiplied by 100% so that the result is reported as a normalized percentage:

During 5-minute period immediately prior to a change in CMS message:

$$\text{Pre-result} = \left(\frac{\text{afterCMS}}{\text{beforeCMS}} - 1 \right) 100\%$$

During 5-minute period immediately following change in CMS message:

$$\text{Post-result} = \left(\frac{\text{afterCMS}}{\text{beforeCMS}} - 1 \right) 100\%$$

The difference between these is taken as an indication of the changes that occurred immediately before and after the warning message was displayed by the CMS:

$$\text{Immediate Change} = \text{Post-result} - \text{Pre-result}$$

These subtracted normalized values from immediately prior to and immediately following the activation of the CMS message are reported for each transition between CMS message states (e.g., blank to 45 mph, or 45 mph to 30 mph, or 30 mph to blank). A typical fog-related event has between two and seven such transitions.

This presentation of data best isolates the CMS message as the sole variable influencing driver response, since the measurements are taken over the 15 minute periods immediately prior to (PRE) and immediately following (POST) the transition of the message. In cases where the CMS message was constant for a period less than 15 minutes, the period (PRE or POST) is shortened to the period that the message was constant, down to a limit of 3 minutes, below which we felt that an insufficient number of vehicles could be recorded to yield a representative mean, STD, or PCS value. The after-CMS to before-CMS normalization helps to reject external factors that may have an effect on the metric, for example, different levels of visibility at each site or natural differences in mean speed due to geometric factors. The

resultant numeric difference values are, however, susceptible to scatter and amplified measurement error (data noise) due the brief periods of observation.

A typical entry, i.e., for mean speed, in the “transition table” looks like:

CMS TRANSITION			Speed (mph)		
Time of Transition	CMS Message		BCMS	ACMS	%chg
11/1/2003 2:59	PRE	BLANK MESSAGE	64.25	64.23	-0.03
	POST	DENSE FOG/ADVISE 45 MPH	68.36	64.28	-5.97
	Period Size: 300s		6.4	0.08	-5.94

It is interpreted as follows:

On 11/1/2003 and 2:59 AM the CMS message changed from BLANK to “DENSE FOG/ADVISE 45 MPH”. The message was displayed for a total of 300 seconds or five minutes.

During the 15-minute period immediately prior to (PRE) this transition, mean speed measured at the two Before-CMS sites was 64.25 mph, and mean speed measured at the two After-CMS sites was 64.23 mph.

During the 5-minute period immediately following (POST) this transition, mean speed measured at the two Before-CMS sites was 68.36 mph, and mean speed measured at the two After-CMS sites was 64.28 mph. A 5-minute period was used rather than 15 minutes because this message was only displayed for 5 minutes before changing again.

The normalized percent difference in mean speed between the two After-CMS and the two Before-CMS sites during the period 15 minutes prior to (PRE) the message transition was –0.03 percent.

The normalized percent difference in mean speed between the two After-CMS and the two Before-CMS sites during the period 5 minutes following (POST) to the message transition was –5.97 percent.

The normalized percent change in mean speed at the two Before-CMS sites between the periods 15 minutes prior to (PRE) and 5 minutes following (POST) the message transition the was 6.4 percent.

The normalized percent change in mean speed at the two After-CMS sites between the periods 15 minutes prior to (PRE) and 5 minutes following (POST) the message transition the was 0.08 percent.

The difference (in percent) between the After-CMS-to-Before-CMS normalized mean speed difference measured in the 5-minute period following (POST) the transition, and the After-CMS-to-Before-CMS mean speed difference measured in the 15 minute period prior to (PRE) the message transition was – 5.94 percent. This negative value indicates that drivers reduced their speed between the Before and After CMS sites more following (POST) the activation of the message than they did prior to (PRE) the message. This suggests that the CMS message was having an effect on driver behavior greater than the behavior of drivers without the message. In this case, traffic mean speed was reduced 5.94% more than

the natural speed reduction of the drivers between the sites immediately following the activation of the CMS than immediately prior to the activation.

As with the constant period tables, on these tables, PCS is reported normalized to the vehicle speed as a percentage. A PCS value equal to the vehicle speed would be 100%. A 0 % would imply that all vehicles were maintaining a PCS of zero mph.

2.8 CAWS Activation Events

During the fog seasons of 2003-04 and 2004-05, CMS 1 was automatically actuated by the CAWS a total of 87 times. Photographs from our surveillance cameras taken during each event are included, showing both pages of the CMS message and a sample view of the traffic. A complete description and Excel-formatted data for all 87 major events that occurred during this two-year period are included in the Appendix CD for this section of the report.

Below we present a subset of these events; a selection of complete event histories during which the CAWS activated or should have activated the CMS for reasons of fog, speed, wind or manual message placement. The selected events are considered representative of the full range of conditions for each type of actuation. One of the criteria for selection was the consistency of conditions before and after the CMS (BCMS and ACMS) over the duration of the event, which best allowed us to examine the effect of the warning message (stimulus) isolated as best as possible from other influences on the traffic. Events are classified by type of actuation.

Notes on Data Presentation:

Traffic, visibility and CMS actuation time records are exact since they were measured by our evaluation system, which are network synchronized to within 0.5 seconds at all times.

For **fog events**, the level of the CMS fog warning message is indicated by a light blue line on the top part of each graph. Three levels are possible. On the short-period moving average plot at the top of each page:

- Blue line value '0' = no message.
- Blue line value '4' = DENSE FOG/ADVISE 45 MPH
- Blue line value '6' = DENSE FOG/ADVISE 30 MPH

On the differential moving average plots (lower graph on each page):

- Blue line value '0' = no message.

- Blue line value '20' = DENSE FOG/ADVISE 45 MPH
- Blue line value '30' = DENSE FOG/ADVISE 30 MPH

For **traffic events**, the level of the CMS traffic (speed) warning message is indicated by a light blue line at the bottom of each graph. Three levels are possible. On the short-period moving average plot at the top of each page:

- Blue line value '0' = no message.
- Blue line value '10' = SLOW TRAFFIC AHEAD
- Blue line value '12' = STOPPED TRAFFIC AHEAD

On the differential moving average plots (lower graph on each page):

- Blue line value '0' = no message.
- Blue line value '50' = SLOW TRAFFIC AHEAD
- Blue line value '60' = STOPPED TRAFFIC AHEAD

Special acronyms:

BCMS = Before Changeable Message Sign. Volume-weighted mean of measurements made at the two monitoring sites Before the CMS, at Downing Road (1.3 miles before CMS) and French Camp Slough (1.2 miles before CMS).

ACMS = After Changeable Message Sign. Volume-weighted mean of measurements made at the two monitoring sites After the CMS, as Mathews Road (.6 miles after CMS) and Ed Dorado O.C. (1.1 miles after the CMS).

Site = Reference to a "site" will usually mean either the two Before-CMS sites or the two After-CMS sites, with data presented as the volume-weighted averages between each pair.

Vis = Visibility measured as an extinction coefficient, in units of miles⁻¹

Vol = Short-period mean traffic Volume, in units of vehicles/minute.

STD = Short-period Standard Deviation of vehicle speeds with respect to the mean, in units of miles/hr.

PCS = Potential Collision Speed, in units of miles per hour.

CMS # = Changeable Message Sign number #. For the present analysis, assume CMS 1 unless otherwise stated.

WS # = Weather Station number #. For the present analysis, assume WS 1 unless otherwise stated, since it activates CMS 1.

2.8.1 Fog Events

Presented below are selected typical events in which CMS 1 actuated or should have actuated due to fog detected at the Mathews Road weather station (WS 1).

2.8.1.1 November 1, 2003, Time: 12am-10am

Synopsis:

Normal actuation except for delayed response and incorrect cutoff of fog warning due to drop in relative humidity.

Files:

2003-11-01-fog-event.xls, 2003-11-01-constant-message-intervals.xls, 2003-11-01-message-transitions.xls

Narrative:

Below are a series of time-history plots covering the duration of this event, broken into two-hour increments per page. The upper plot on each page shows short-period moving window mean speed, speed standard deviation, and PCS at Before-CMS and After-CMS sites. Also visibility extinction coefficient before and after the CMS, and traffic volume moving average at all sites. The lower plot on each page shows the difference in each of these metrics between the After-CMS and Before-CMS site.

Following the onset of fog at approximately 1:22 AM, there is a abrupt but small drop in mean speed ACMS relative to BCMS, probably because visibility was initially worse ACMS than BCMS. During the period from 2:00 AM – 2:15 AM, visibility was much worse at Mathews Road. Drivers slowed from 3-5 MPH, despite the cut-off of the warning message due to a low RH reading. This reaction is the same as that during periods in which the message was properly displayed. During the period from 2:20 AM – 2:50 AM, visibility became more severe at French Camp Slough, and vehicles BCMS slowed 3-5 mph relative to the ACMS sites. At 2:38 AM visibility at both sites was equally poor and all metrics BCMS and ACMS were about equal. This period showed that drivers equalized their speeds and PCS at the two sites when visibility was almost equally low, without a message on the CMS. Drivers clearly respond to their own perceptions rather than a warning message.

Mean speeds remained slightly lower while PCS increased and STD remained relatively unaffected at whichever site had lower visibility until CMS activation eventually occurred at 3:00 AM. Figure 2.8.1.1 shows the 2-page warning message displayed at approximately 3:30 AM, and a view of the traffic in dense fog conditions, taken by the evaluation video cameras at the CMS site. At 1:58 AM the CMS should have activated with a dense fog message because visibility < 500 ft. We have no definitive explanation for the nearly two-hour delay in the activation of the CMS, which was warranted by visibility conditions at Mathews Road, the site of WS1. We verified that the QCMS computer did receive valid data for fog-related visibility during this time. Possibly Signview was stopped or being backed up, communications to the CMS were down, or the serial link between Signview and the QCMS computer failed.

From 3:00 AM to 4:00 AM, Signview operated normally, displaying 45 and 30 mph advisory messages. Visibility was notably worse ACMS, and traffic speeds ACMS were about 3-5 mph lower than BCMS. It is noteworthy, however, that traffic continued at mean speeds between 60 and 65 mph ACMS when advised to go 30 mph. Between 4:14 AM and 4:18 AM, Signview sent a blank message to the French Camp CMS. This occurred because the QCMS computer reported visibility as non-fog related due to a drop in the relative humidity from 77% to 75% reported at the Mathews Road Weather Station. The QCMS only interprets low visibility as fog if the RH is 75% or greater.

While the CMS was activated with either 45 mph or 30 mph warning messages during this period, mean speed decreased slightly but PCS increased significantly ACMS. But note that visibility was worse ACMS for most of this period. This suggests that drivers slowed down, but not nearly enough to compensate for the reduced visibility; traffic was less safe ACMS. Between 4:00 and 5:00 visibility improved and the CMS was extinguished twice. All metrics approximately equalized during this period.

Signview blanked the CMS between 4:35 AM and 5:03 AM. The first 10 minutes of this period occurred when visibility rose above 500 Feet. However, the last 18 minutes of this period occurred when visibility was below 500 Feet. This time, the Mathews Road Weather Station reported a gradual drop in the relative humidity reading from 77% to 72%. The QCMS computer generated a Level 1 non-fog visibility warning flag during this time, which does did not activate a warning message.

At 5:00 AM, visibility worsened again, and the CMS activated until 7:40 AM. Mean speed was slightly lower and PCS was higher at the site with worse visibility, which was ACMS for most of this period. Between 7:00 and 7:30 AM visibility became much worse ACMS, and PCS became very high compared with BCMS. Following CMS deactivation at 7:40, mean speed stabilized at approximately 70 mph, and all metrics equalized between BCMS and ACMS, as traffic volume increased through the morning rush hour.

Figure 2.8.1.1. Time history of event in two-hour increments (series of plots below).

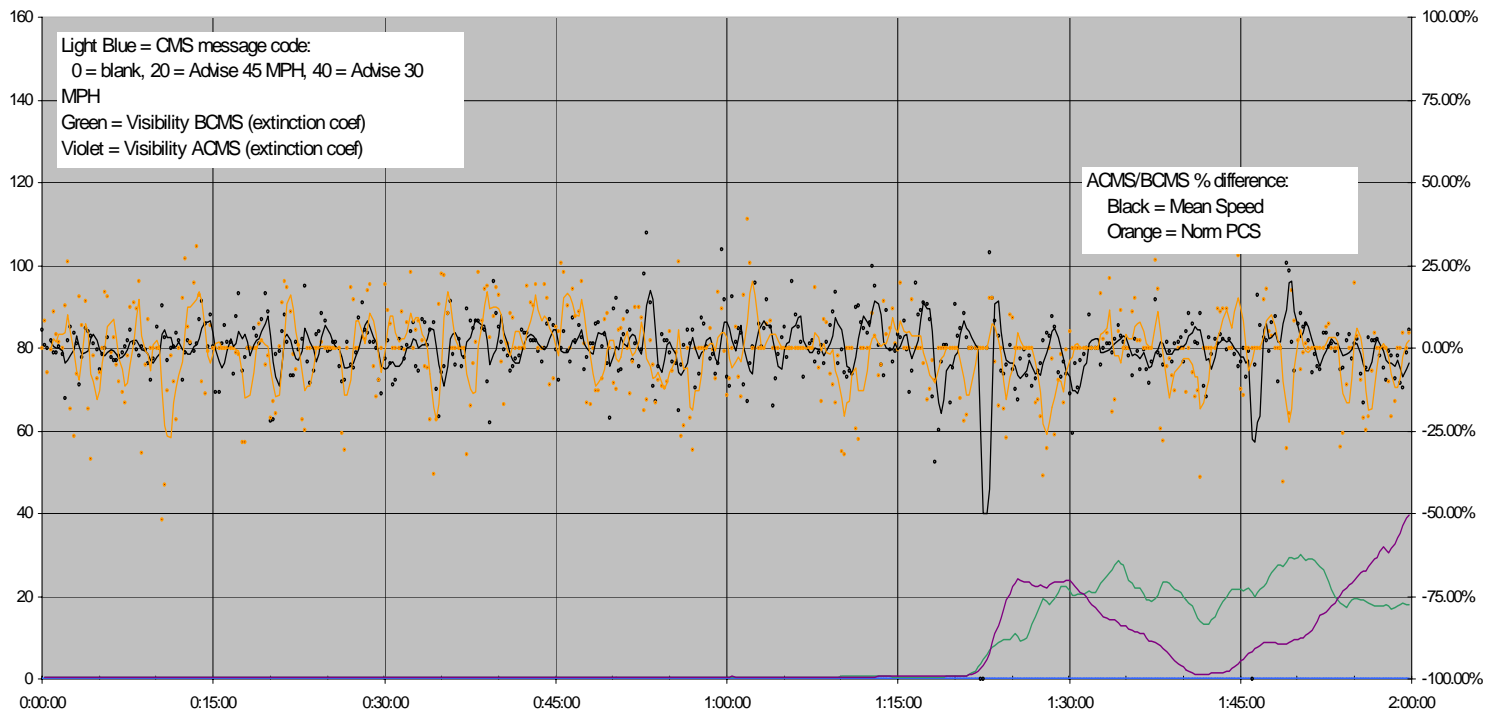
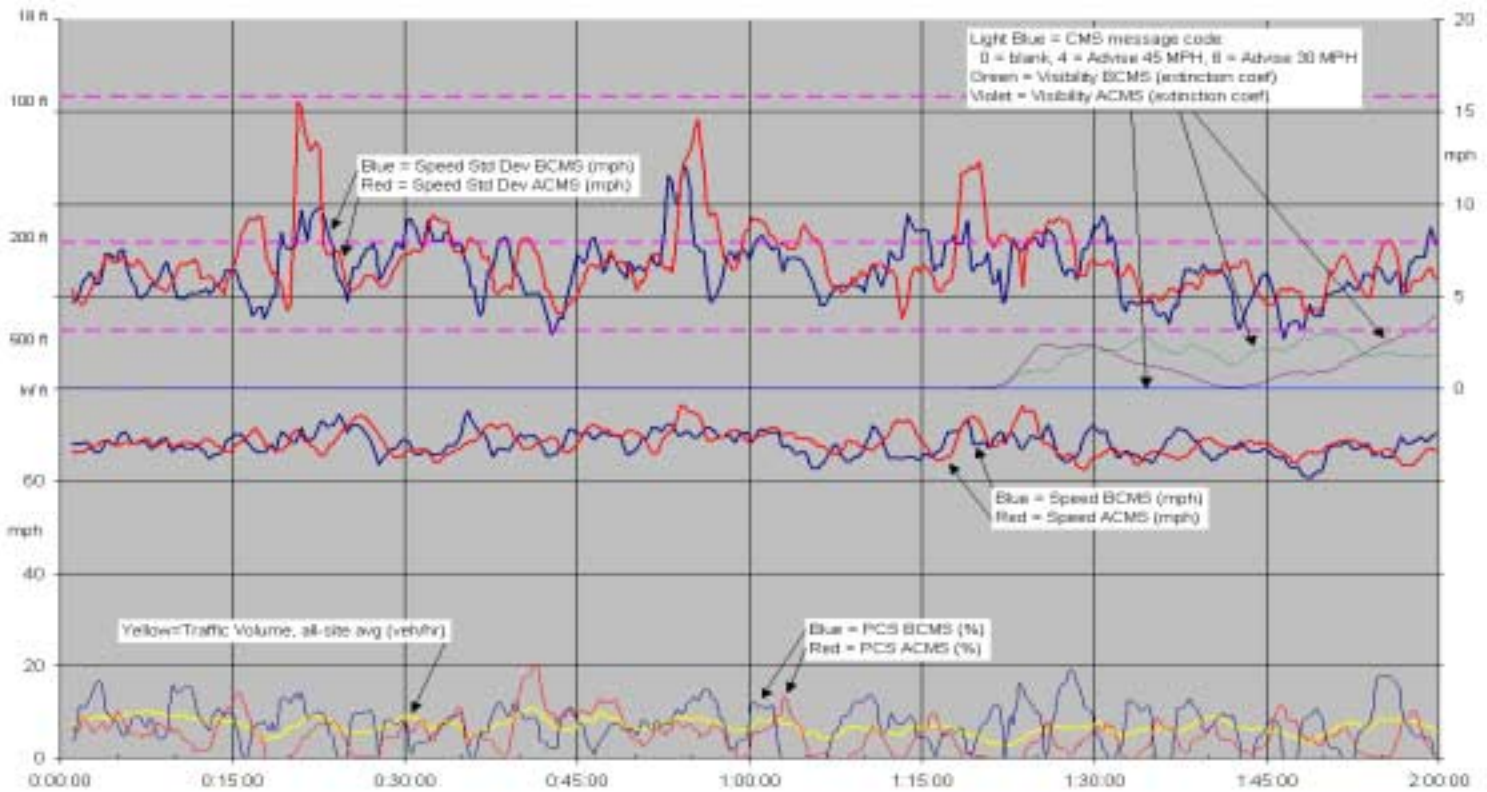

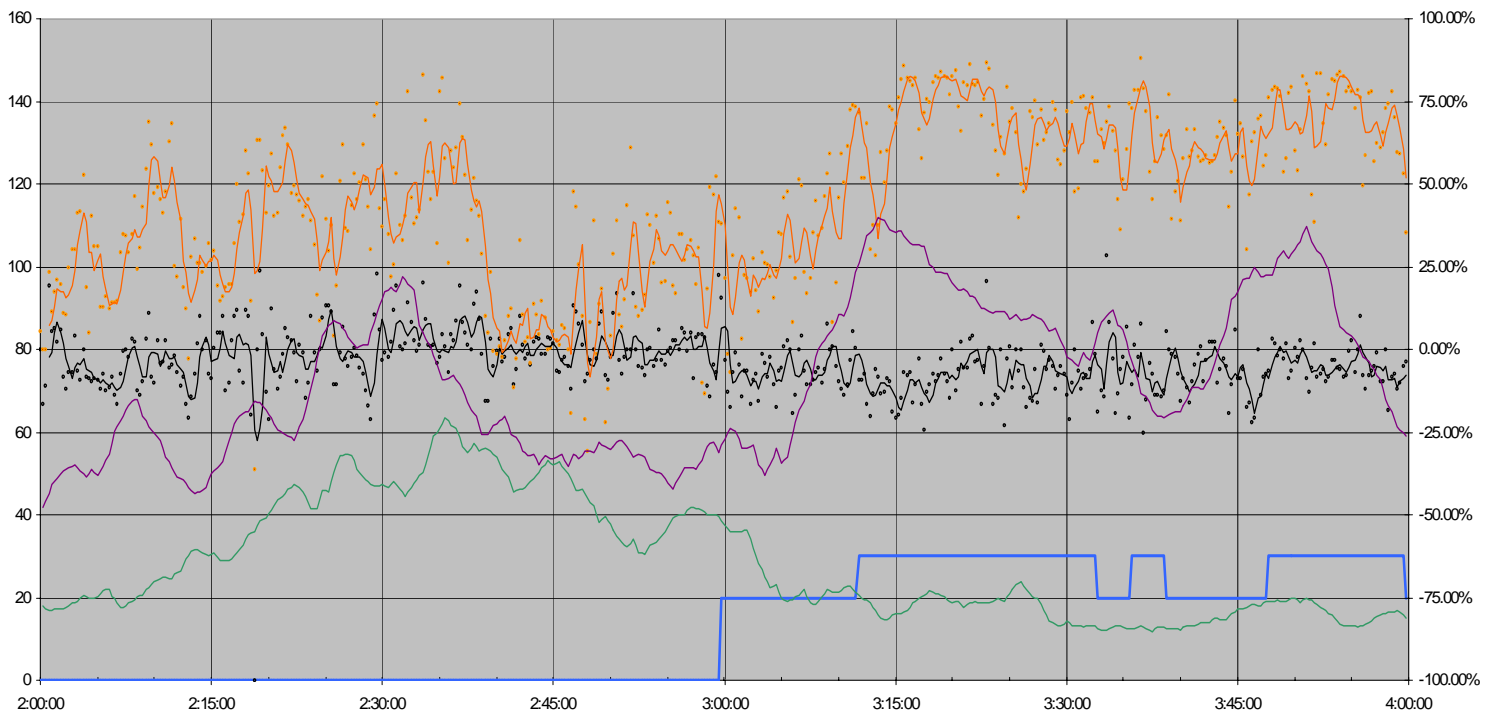
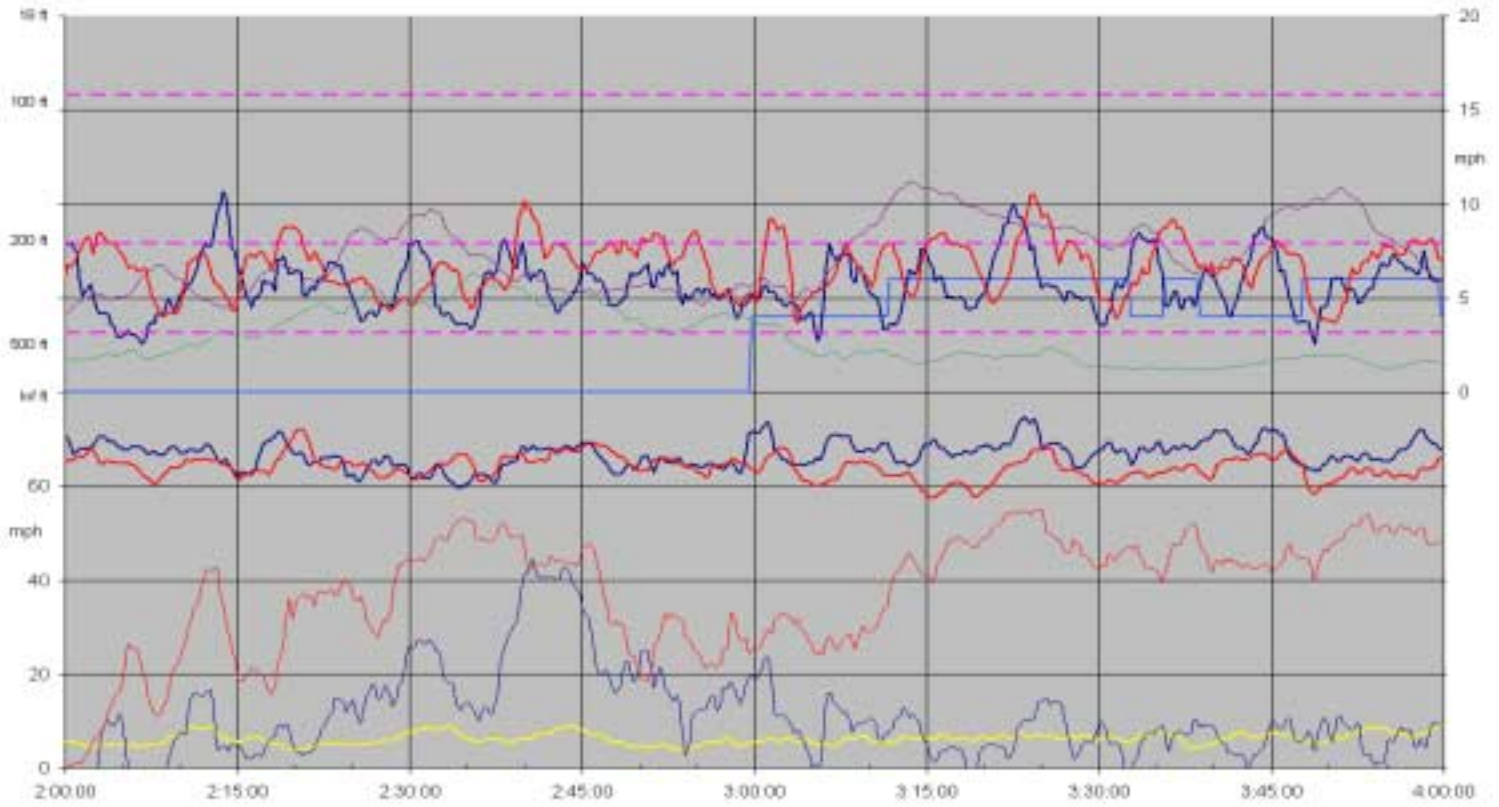

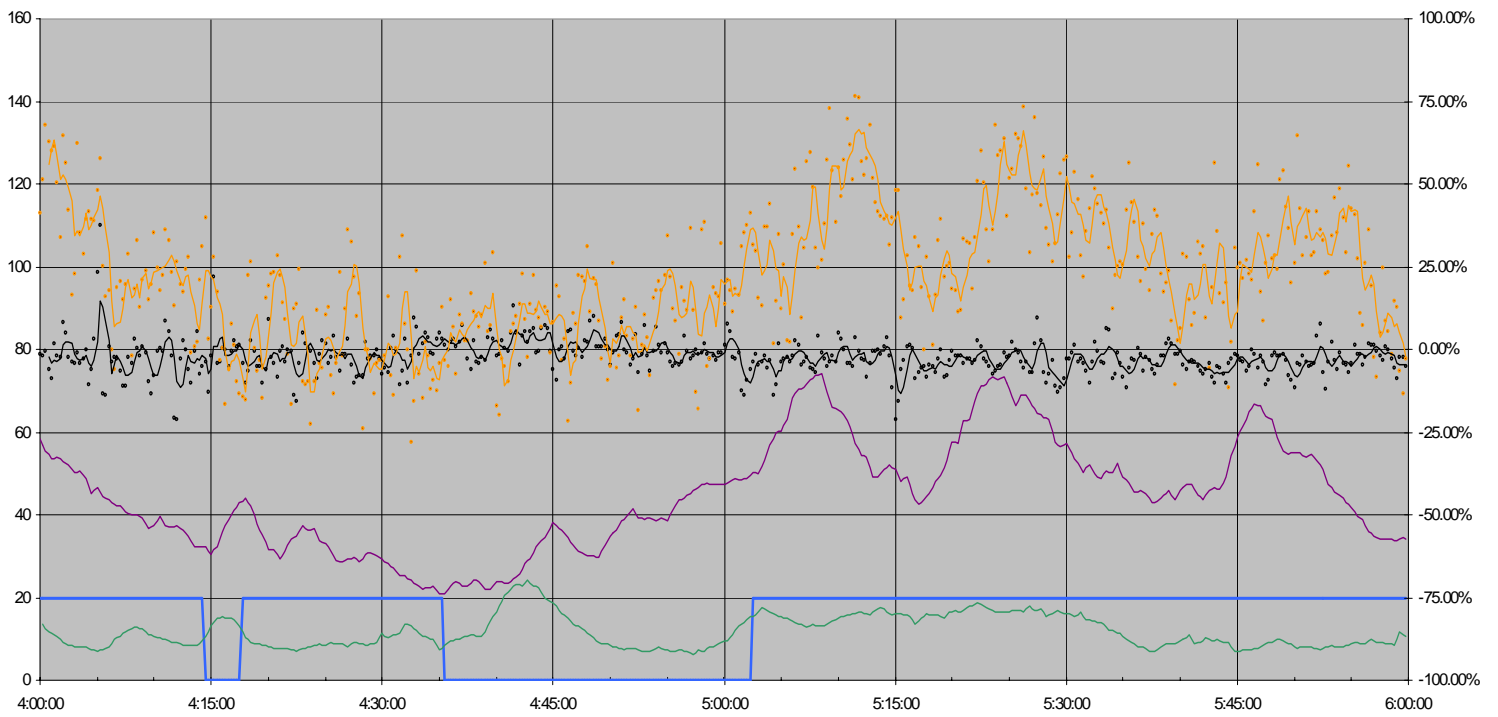
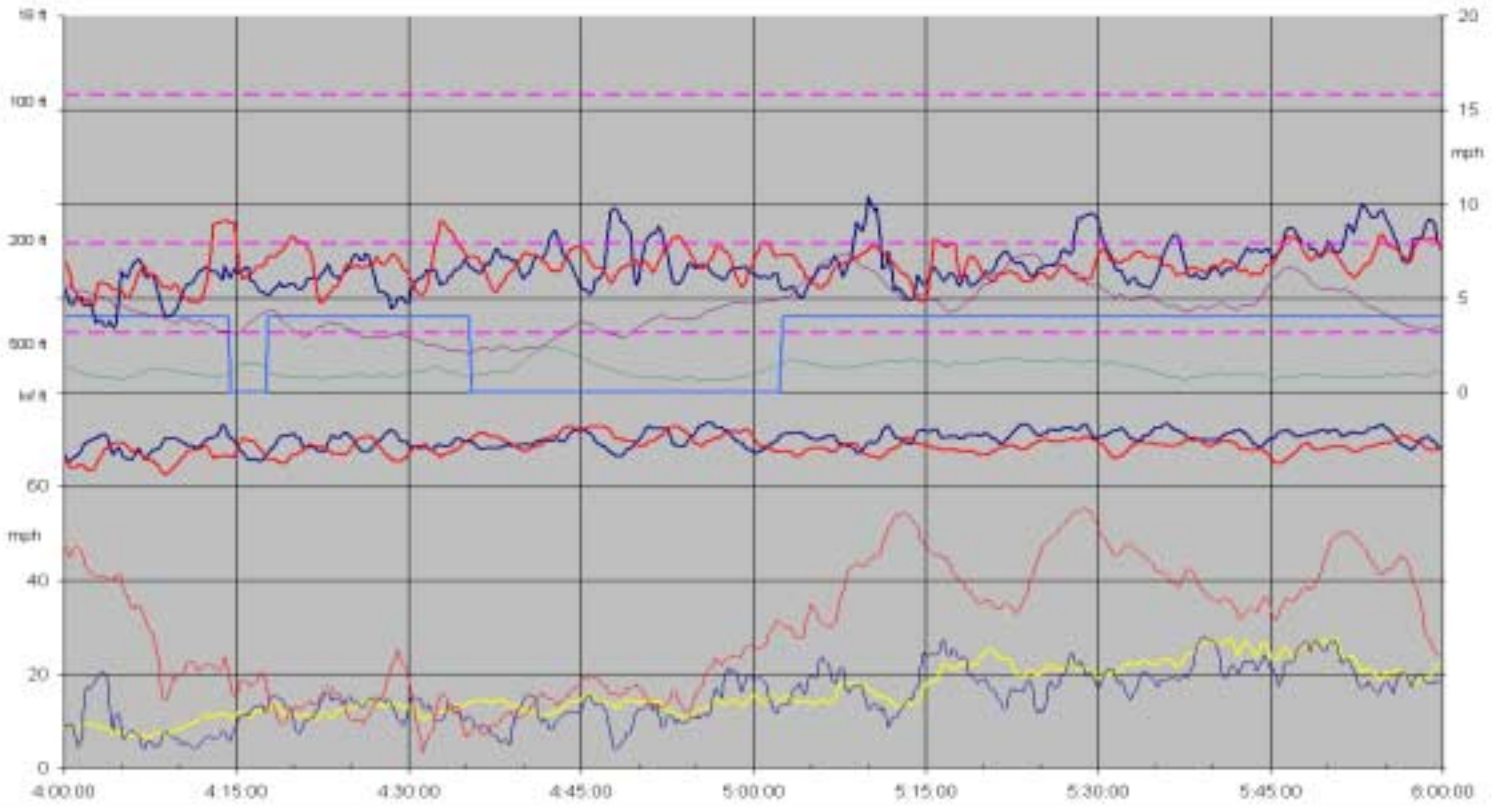

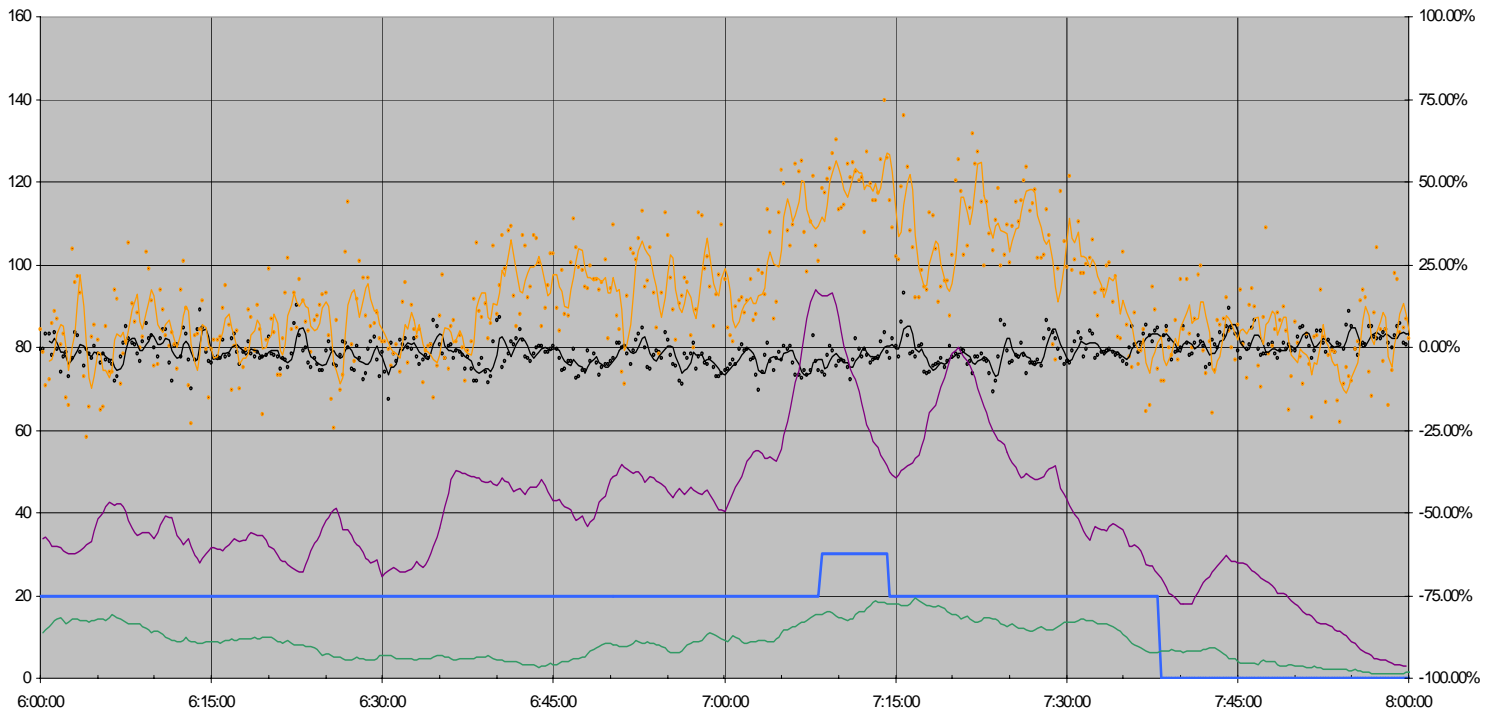
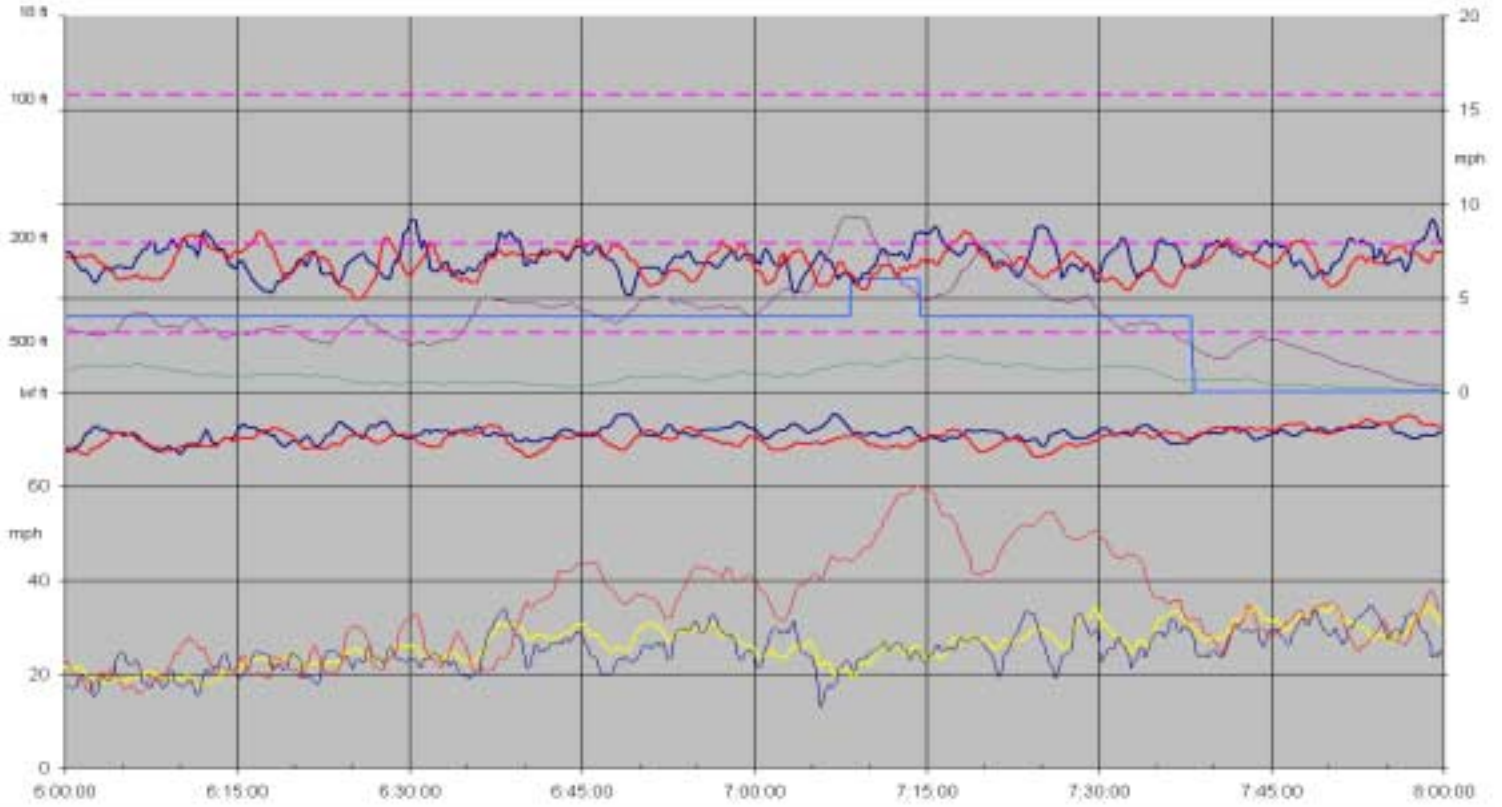

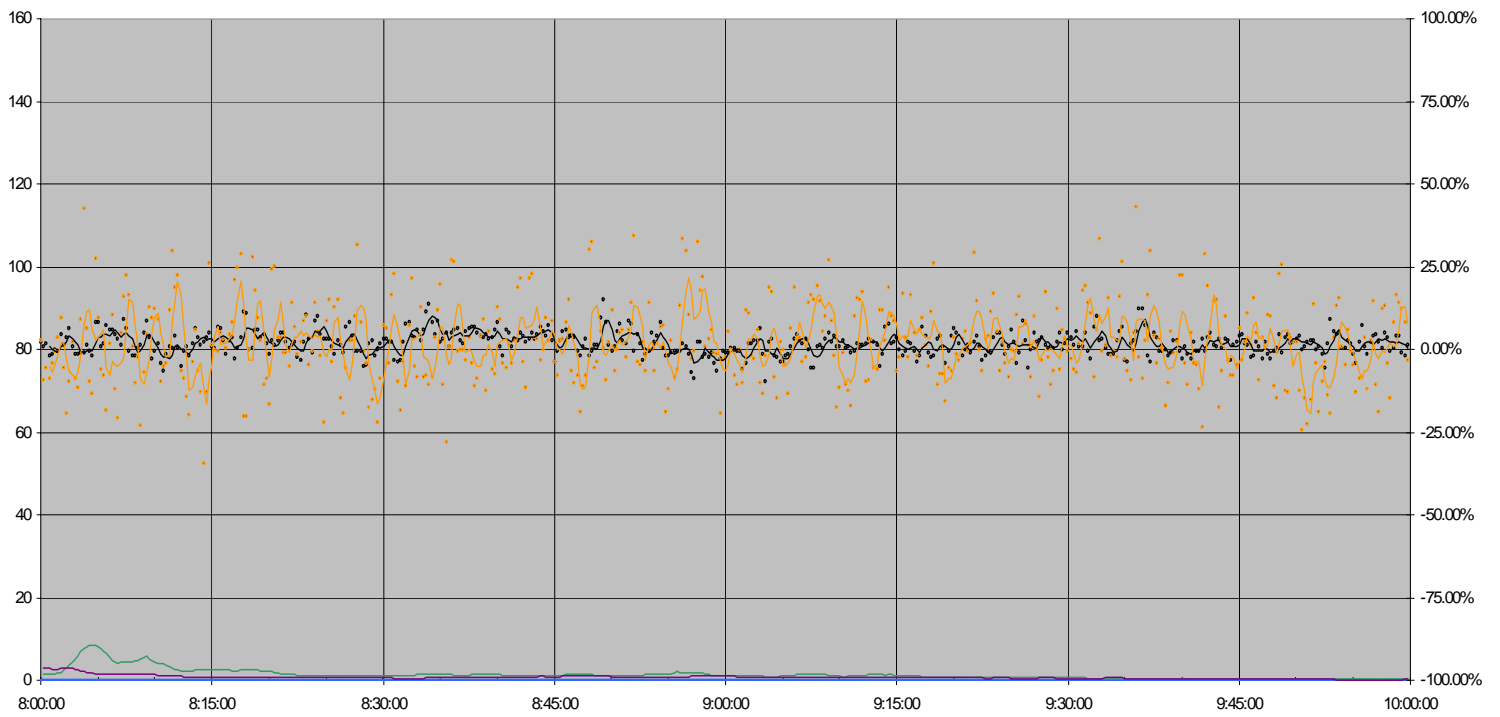
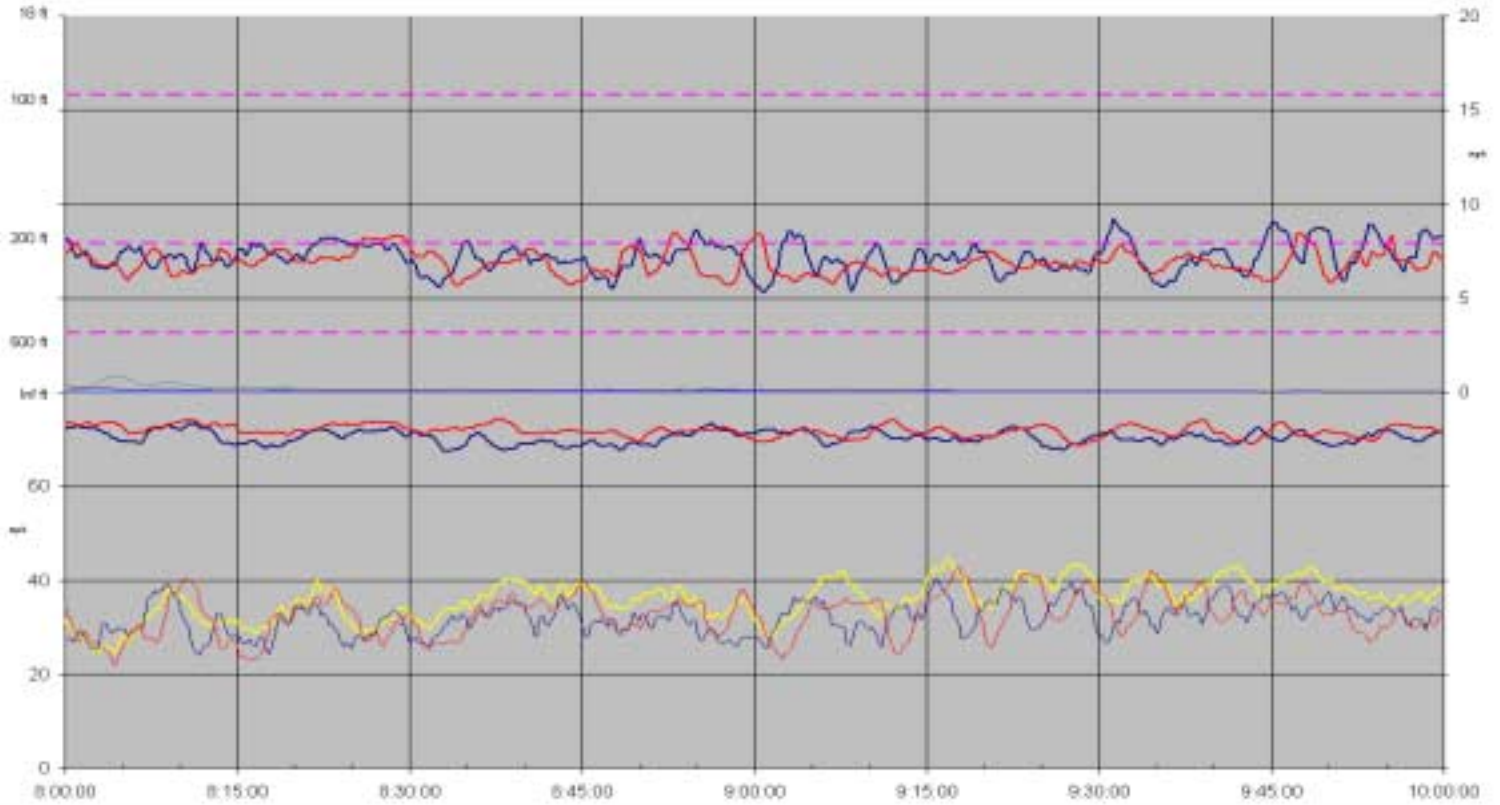



Page 1 of CMS message



Page 2 of CMS message



Sample traffic image

Figure 2.8.1.2. CMS 2-page message and sample traffic during event, from evaluation video camera

Table 2.8.1.1. Normalized differences, After-CMS sites VS Before-CMS sites, during constant message periods.

Start Time (mo/day/yr hr:min)	Period (sec)	CMS Messages	Speed (mph)			Stddev (mph)			Norm PCS(%)			Volume (Veh/Hr)			Vis (Extinction Coef)		
			BCMS	ACMS	%chg	BCMS	ACMS	%chg	BCMS	ACMS	%chg	BCMS	ACMS	%chg	BCMS	ACMS	%chg
11/1/2003 2:59	719	DENSE FOG/ADVISE 45 MPH	68.43	63.86	-6.68	7.78	7.98	2.57	16.58	44.6	169	666	746	12.03	26.55	71.51	169.34
11/1/2003 3:11	719	DENSE FOG/ADVISE 30 MPH	67.47	61.55	-8.77	7.74	8.87	14.6	8.89	78.04	777.84	731	816	11.64	18.72	99.74	432.8
11/1/2003 3:32	180	DENSE FOG/ADVISE 45 MPH	67.18	62.73	-6.62	10.57	9.02	-14.66	7.1	66.7	839.44	880	1100	25	12.78	80.56	530.36
11/1/2003 3:35	180	DENSE FOG/ADVISE 30 MPH	67.3	63.46	-5.71	6.84	8.42	23.1	12.74	73.39	476.06	480	580	20.83	12.57	65.11	417.98
11/1/2003 3:38	180	DENSE FOG/ADVISE 45 MPH	70.09	64.86	-7.46	6.99	8.18	17.02	9.92	65.84	563.71	520	820	57.69	12.61	69.58	451.78
11/1/2003 3:47	540	DENSE FOG/ADVISE 30 MPH	65.32	62.18	-4.81	6.4	7.21	12.66	10.17	79.54	682.1	813	900	10.66	17.33	92.5	433.76
11/1/2003 3:59	719	DENSE FOG/ADVISE 45 MPH	68.36	66.08	-3.34	7.28	6.34	-12.91	15.03	47.83	218.23	911	1061	16.48	10.64	43.65	310.24
11/1/2003 4:14	190	BLANK MESSAGE	67.86	67.14	-1.06	8.6	7.85	-8.72	17.12	22.83	33.35	1364	1440	5.56	12.97	40.9	215.34
11/1/2003 4:17	190	DENSE FOG/ADVISE 45 MPH	68.71	67.13	-2.3	6.38	8.57	34.33	22.18	19.39	-12.58	1137	1478	30	10.4	32.73	214.71
11/1/2003 4:35	1070	BLANK MESSAGE	69.53	70.65	1.61	8.42	7.39	-12.23	16.17	21.45	32.65	1464	1787	22.07	13.77	31.25	126.94
11/1/2003 5:02	1629	DENSE FOG/ADVISE 45 MPH	70.81	68.41	-3.39	7.75	7.17	-7.48	27.83	62.35	124.04	2122	2373	11.88	15.9	60.53	280.69
11/1/2003 7:08	359	DENSE FOG/ADVISE 30 MPH	71.44	68.93	-3.51	7.29	6.85	-6.04	36.47	80.72	121.33	2818	3179	12.81	15.83	63.01	298.04
11/1/2003 7:14	359	DENSE FOG/ADVISE 45 MPH	70.69	69.54	-1.63	8.61	8.1	-5.92	38.18	66.61	74.46	2868	3299	15.03	17.88	66.9	274.16
11/1/2003 7:38	1430	BLANK MESSAGE	71.56	72.76	1.68	7.86	7.44	-5.34	42.6	43.99	3.26	3489	3852	10.39	3.64	14.58	300.55

Table 2.8.1.2. Normalized change in metrics measured during period 15 minutes after vs period 15 minutes before each message transition.

CMS TRANSITION			Speed (mph)			Stddev (mph)			Norm PCS (%)			Volume (Veh/Hr)			Vis (Extinction Coef)		
Time of Transition	of	CMS Message	BCMS	ACMS	%chg	BCMS	ACMS	%chg	BCMS	ACMS	%chg	BCMS	ACMS	%chg	BCMS	ACMS	%chg
11/1/2003 2:59	PRE	BLANK MESSAGE	64.25	64.23	-0.03	6.24	6.07	-2.72	23.65	44.97	90.15	624	696	11.54	38.93	54.56	40.15
	POST	DENSE FOG/ADVISE 45 MPH	68.36	64.28	-5.97	8	8.44	5.5	19.27	42.73	121.74	744	756	1.61	34.68	54.61	57.47
	Period Size: 300s			6.4	0.08	-5.94	28.21	39.04	8.45	-18.52	-4.98	16.62	19.23	8.62	-8.9	-10.92	0.09
11/1/2003 3:11	PRE	DENSE FOG/ADVISE 45 MPH	69.6	63.94	-8.13	7.84	7.65	-2.42	17.9	48.46	170.73	648	828	27.78	20.57	90.61	340.5
	POST	DENSE FOG/ADVISE 30 MPH	66.66	59.77	-10.34	7.97	8.04	0.88	13.64	72.36	430.5	708	732	3.39	17.88	108	504.14
	Period Size: 300s			-4.22	-6.52	-2.4	1.66	5.1	3.38	-23.8	49.32	95.95	9.26	-11.59	-19.09	-13.08	19.21
11/1/2003 3:32	PRE	DENSE FOG/ADVISE 30 MPH	68.59	62.55	-8.81	4.85	5.88	21.24	12.6	75.58	499.84	700	800	14.29	13.37	81.43	509.05
	POST	DENSE FOG/ADVISE 45 MPH	67.18	62.73	-6.62	10.57	9.02	-14.66	7.1	66.7	839.44	880	1100	25	12.78	80.56	530.36
	Period Size: 180s			-2.06	0.29	2.39	117.94	53.4	-29.61	-43.65	-11.75	56.61	25.71	37.5	9.38	-4.41	-1.07

Evaluation of Caltrans Automated Warning System

Analysis of Driver Response

11/1/2003 3:35	PRE	DENSE FOG/ADVISE 45 MPH	67.18	62.73	-6.62	10.57	9.02	-14.66	7.1	66.7	839.44	880	1100	25	12.78	80.56	530.36
	POST	DENSE FOG/ADVISE 30 MPH	67.3	63.46	-5.71	6.84	8.42	23.1	12.74	73.39	476.06	480	580	20.83	12.57	65.11	417.98
	Period Size: 180s		0.18	1.16	0.98	-35.29	-6.65	44.25	79.44	10.03	-38.68	-45.45	-47.27	-3.33	-1.64	-19.18	-17.83
11/1/2003 3:38	PRE	DENSE FOG/ADVISE 30 MPH	67.3	63.46	-5.71	6.84	8.42	23.1	12.74	73.39	476.06	480	580	20.83	12.57	65.11	417.98
	POST	DENSE FOG/ADVISE 45 MPH	70.09	64.86	-7.46	6.99	8.18	17.02	9.92	65.84	563.71	520	820	57.69	12.61	69.58	451.78
	Period Size: 180s		4.15	2.21	-1.86	2.19	-2.85	-4.94	-22.14	-10.29	15.22	8.33	41.38	30.5	0.32	6.87	6.53
11/1/2003 3:47	PRE	DENSE FOG/ADVISE 45 MPH	69.47	65.19	-6.16	9.21	9.02	-2.06	7.58	65.74	767.28	756	792	4.76	15.96	96.05	501.82
	POST	DENSE FOG/ADVISE 30 MPH	64.73	61.55	-4.91	6.02	6.4	6.31	14.83	77.77	424.41	828	780	-5.8	19.22	102.8	434.96
	Period Size: 300s		-6.82	-5.58	1.33	-34.64	-29.05	8.55	95.65	18.3	-39.53	9.52	-1.52	-10.08	20.43	7.05	-11.11
11/1/2003 3:59	PRE	DENSE FOG/ADVISE 30 MPH	68.42	64.09	-6.33	8.12	8.27	1.85	6.27	77.27	1132.3	768	900	17.19	14.35	67.11	367.67
	POST	DENSE FOG/ADVISE 45 MPH	68.63	66.24	-3.48	6.64	6.36	-4.22	20.3	64.93	219.85	1176	1188	1.02	11.54	49.82	331.72
	Period Size: 300s		0.31	3.35	3.04	-18.23	-23.1	-5.95	223.76	-15.97	-74.05	53.13	32	-13.8	-19.58	-25.76	-7.69
11/1/2003 4:14	PRE	DENSE FOG/ADVISE 45 MPH	69.33	66.84	-3.59	7.58	9.79	29.16	8.71	30.07	245.24	1307	1611	23.19	8.91	32.99	270.26
	POST	BLANK MESSAGE	67.86	67.14	-1.06	8.6	7.85	-8.72	17.12	22.83	33.35	1364	1440	5.56	12.97	40.9	215.34
	Period Size: 190s		-2.12	0.45	2.62	13.46	-19.82	-29.33	96.56	-24.08	-61.37	4.35	-10.59	-14.31	45.57	23.98	-14.83
11/1/2003 4:17	PRE	BLANK MESSAGE	67.86	67.14	-1.06	8.6	7.85	-8.72	17.12	22.83	33.35	1364	1440	5.56	12.97	40.9	215.34
	POST	DENSE FOG/ADVISE 45 MPH	68.71	67.13	-2.3	6.38	8.57	34.33	22.18	19.39	-12.58	1137	1478	30	10.4	32.73	214.71
	Period Size: 190s		1.25	-0.01	-1.25	-25.81	9.17	47.16	29.56	-15.07	-34.44	-16.67	2.63	23.16	-19.81	-19.98	-0.2
11/1/2003 4:35	PRE	DENSE FOG/ADVISE 45 MPH	68.58	68.55	-0.04	6.75	8.55	26.67	20.14	18.55	-7.89	1464	1500	2.46	11.37	22.8	100.53
	POST	BLANK MESSAGE	68.67	69.15	0.7	7.28	6.87	-5.63	14.06	17.54	24.75	1512	1872	23.81	10.06	23.31	131.71
	Period Size: 300s		0.13	0.88	0.74	7.85	-19.65	-25.5	-30.19	-5.44	35.44	3.28	24.8	20.84	-11.52	2.24	15.55
11/1/2003 5:02	PRE	BLANK MESSAGE	69.32	68.77	-0.79	7.12	7.69	8.01	28.02	39.3	40.26	1596	1824	14.29	9.41	48.97	420.4
	POST	DENSE FOG/ADVISE 45 MPH	70.82	68.35	-3.49	6.46	6.85	6.04	25.01	50.6	102.32	1620	1980	22.22	15.39	66.98	335.22
	Period Size: 300s		2.16	-0.61	-2.72	-9.27	-10.92	-1.82	-10.74	28.75	44.25	1.5	8.55	6.94	63.55	36.78	-16.37
11/1/2003 7:08	PRE	DENSE FOG/ADVISE 45 MPH	73.27	69.79	-4.75	7.27	6.38	-12.24	29.54	60.54	104.94	2412	2724	12.94	11.6	80.66	595.34
	POST	DENSE FOG/ADVISE 30 MPH	70.92	68.53	-3.37	7.09	6.79	-4.23	35.8	80.21	124.05	2748	3204	16.59	15.54	65.74	323.04
	Period Size: 300s		-3.21	-1.81	1.45	-2.48	6.43	9.13	21.19	32.49	9.32	13.93	17.62	3.24	33.97	-18.5	-39.16
11/1/2003 7:14	PRE	DENSE FOG/ADVISE 30 MPH	71.3	68.92	-3.34	7.47	7.03	-5.89	36.77	82.84	125.29	2784	3180	14.22	15.87	58.86	270.89
	POST	DENSE FOG/ADVISE 45 MPH	70.45	69.79	-0.94	8.33	8.29	-0.48	35.9	67.73	88.66	2724	3264	19.82	18.02	64.94	260.38
	Period Size: 300s		-1.19	1.26	2.48	11.51	17.92	5.75	-2.37	-18.24	-16.26	-2.16	2.64	4.9	13.55	10.33	-2.83
11/1/2003 7:38	PRE	DENSE FOG/ADVISE 45 MPH	70.97	70.96	-0.01	7.67	6.64	-13.43	42.57	48.75	14.52	3432	3960	15.38	10.2	27.38	168.43
	POST	BLANK MESSAGE	71.68	72.18	0.7	7.96	7.8	-2.01	37.83	42.49	12.32	3252	3864	18.82	6.66	23.47	252.4
	Period Size: 300s		1	1.72	0.71	3.78	17.47	13.19	-11.13	-12.84	-1.92	-5.24	-2.42	2.98	-34.71	-14.28	31.28

2.8.1.2 November 16, 2003, Time: 12am-10am

Synopsis:

Fog event in which the system failed to actuate. Reference case for observing the natural response of drivers to fog at ACMS sites.

Files:

2003-11-16-fog-event.xls, 2003-11-16-constant-message-intervals.xls, 2003-11-16-message-transitions.xls

Narrative:

This event is interesting as a baseline case, for observation of the response of drivers to dense fog in the absence of any warning message.

Dense fog was detected at Mathews Road, but Signview did not actuate the CMS. The QCMS computer log recorded missing data entries for the Mathews Road Weather Station. Problem was eventually found to be due to a failed communications link between the Mathews Road weather station and the QCMS for unknown reasons, although the weather station was powered and fully operational, according to our monitoring equipment at the site.

At approximately 1:30 AM, a rapid decrease in visibility occurred at the Mathews Road site while the visibility at the French Camp Slough site remained high. Drivers decreased speed at the 'after' sites by 8-10 MPH from approximately 71 MPH to 62 MPH due to the decrease in visibility. Between 2:15 and 2:45 AM, visibility became much better at the Mathews Road site. Correspondingly, speeds at the 'after' sites begin to increase and almost equalize with the 'before' sites at approximately 71 MPH. Between 2:45 and 3:30 AM, visibility became much worse at the Mathews Road site, again. Traffic at the sites slowed by approximately 5-8 MPH from 67 MPH to 61 MPH. At 3:30 AM, the visibility at French Camp Slough became extremely poor. At 3:27 AM, visibility was less than 100 ft., yet mean speeds at both sites were approximately 70 mph. PCS peaked at 100% of the mean traffic speed, or nearly 70 mph. And between 4:30 and 5:30 AM, visibility ACMS was particularly poor, and PCS averaged 90%. This means that, at 3:27 AM, if there had been a traffic disturbance of any kind, which lead to a traffic stoppage, *every vehicle on the highway would collide with the stoppage before the driver had a chance to brake.*

At 3:33 AM, visibility became significantly worse at French Camp Slough than at Mathews Road. This resulted in a reversal of speeds at the sites. Drivers accelerated approximately 10 MPH from the 'before' sites to the 'after' sites from 56 MPH to 66 MPH. Between 4:15 and 4:30 AM, both visibility stations reported a rapid increase in visibility. Driver speeds at the 'before' sites increased from 57 MPH to 69 MPH and momentarily equalized with the 'after' sites around 4:22 AM. Mathews Road visibility decreased significantly from 4:40 to 5:25 AM when compared to the visibility at French Camp Slough. Vehicles slowed down approximately 3-5 MPH. At 6:30 AM, vehicles were traveling 3 MPH quicker at the 'after' sites. This changed briefly during the last fog bank. Visibility became worse

at the Mathews Road station, but there was no change in mean speed at the 'after' sites. However, mean speeds increased at the BCMS sites as fog BCMS decreased.

Again, speed standard deviation appeared only minimally affected by any of the conditions. Overall, the responses observed during this event were the same as those observed when the CMS was operational.

Figure 2.8.1.3. Time history of event in two-hour increments (series of plots below).

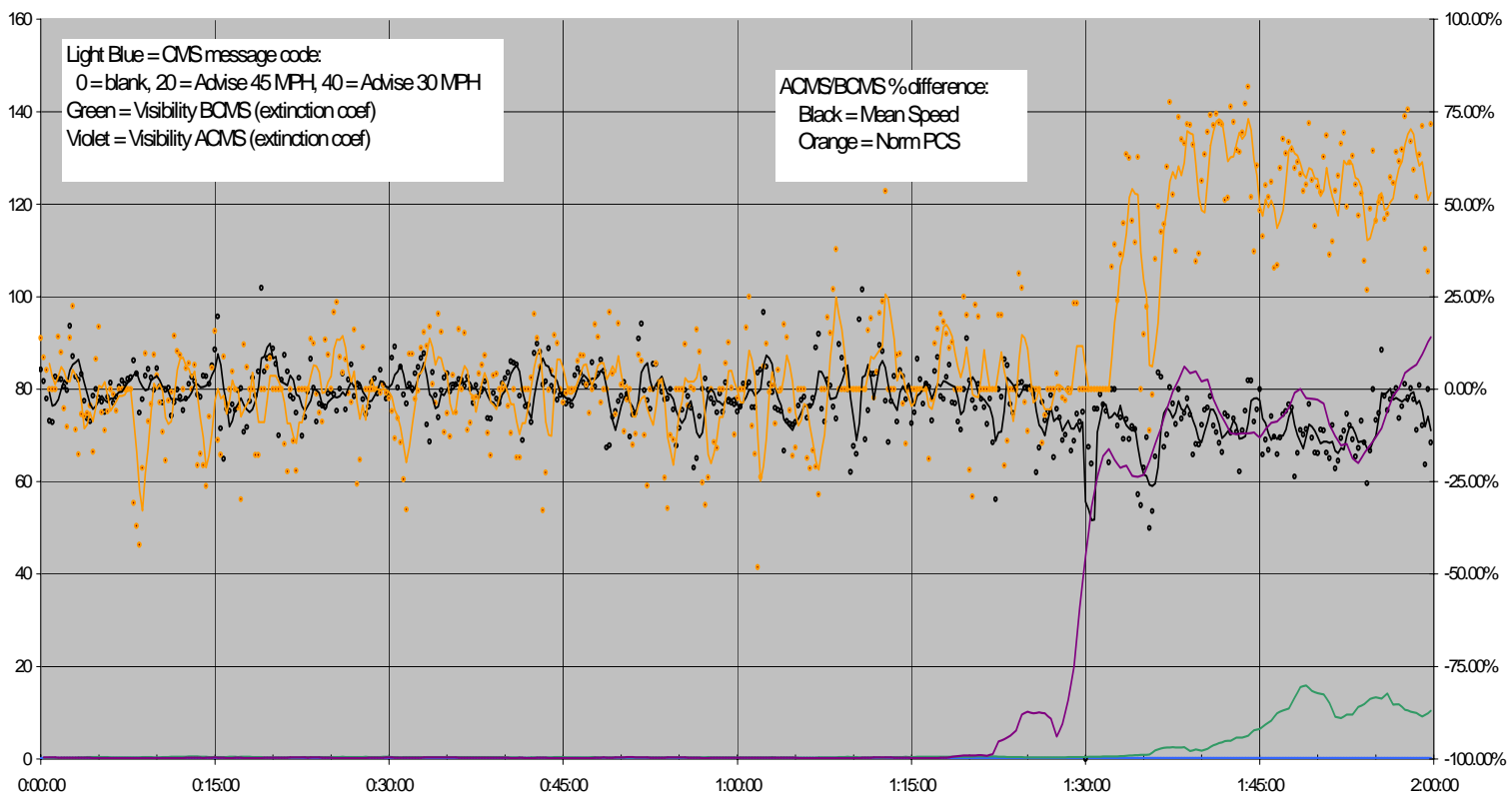
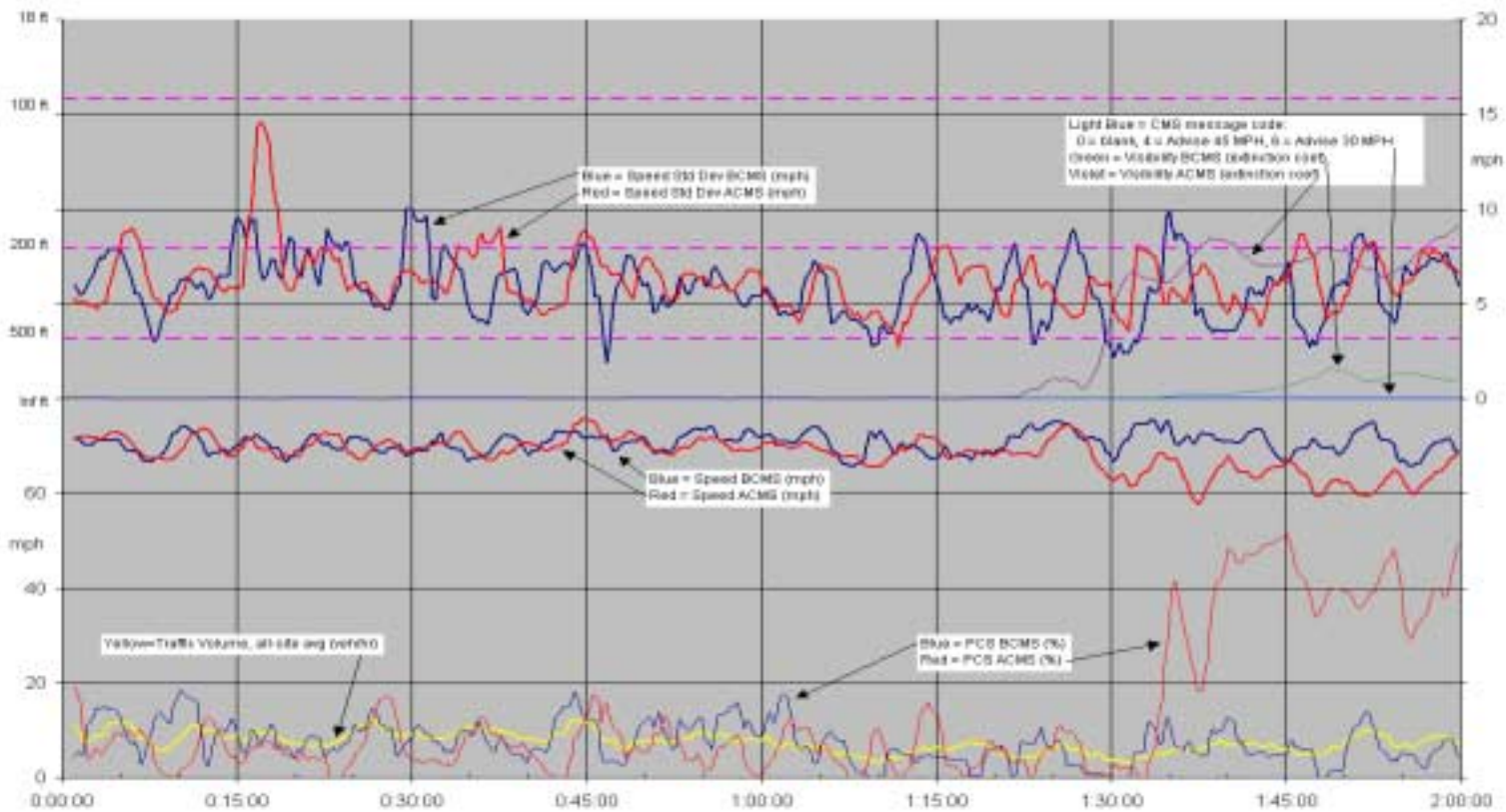

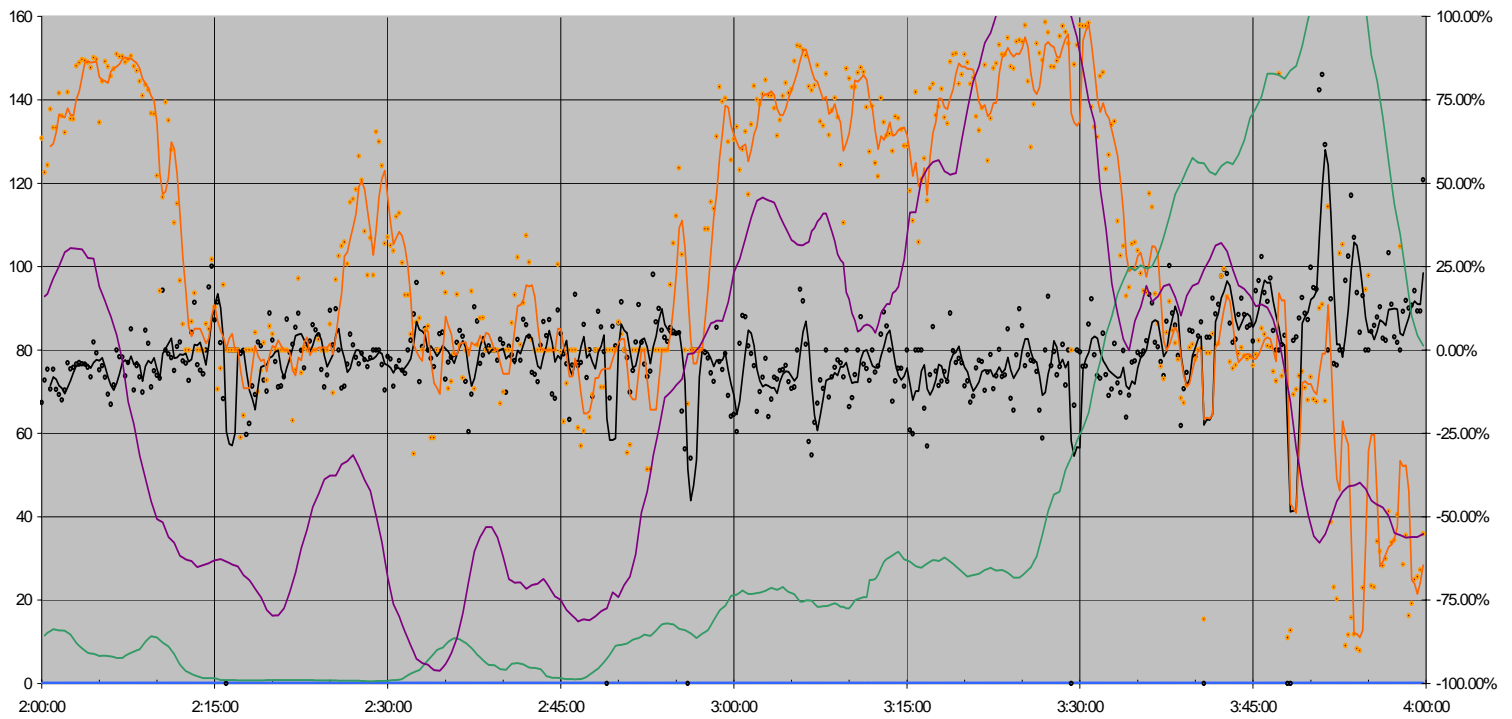

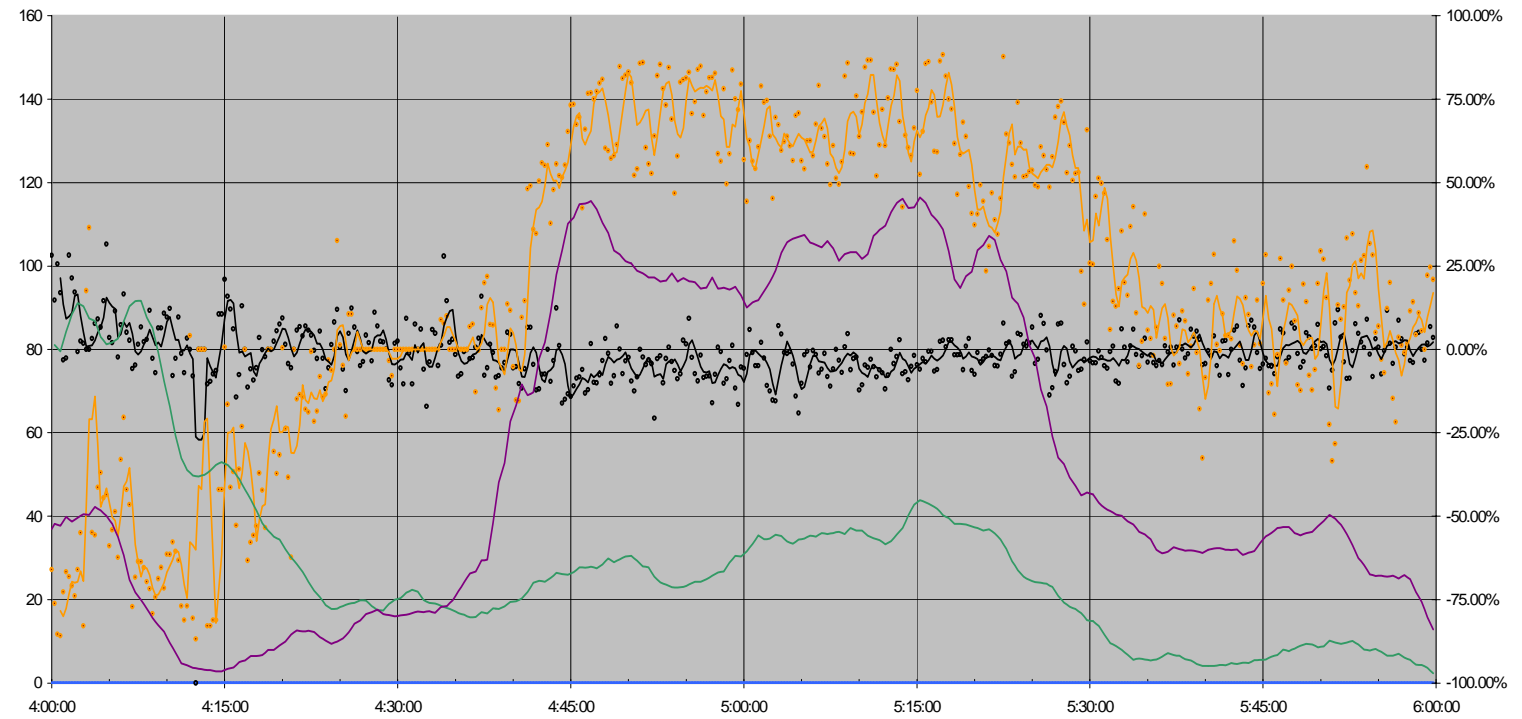
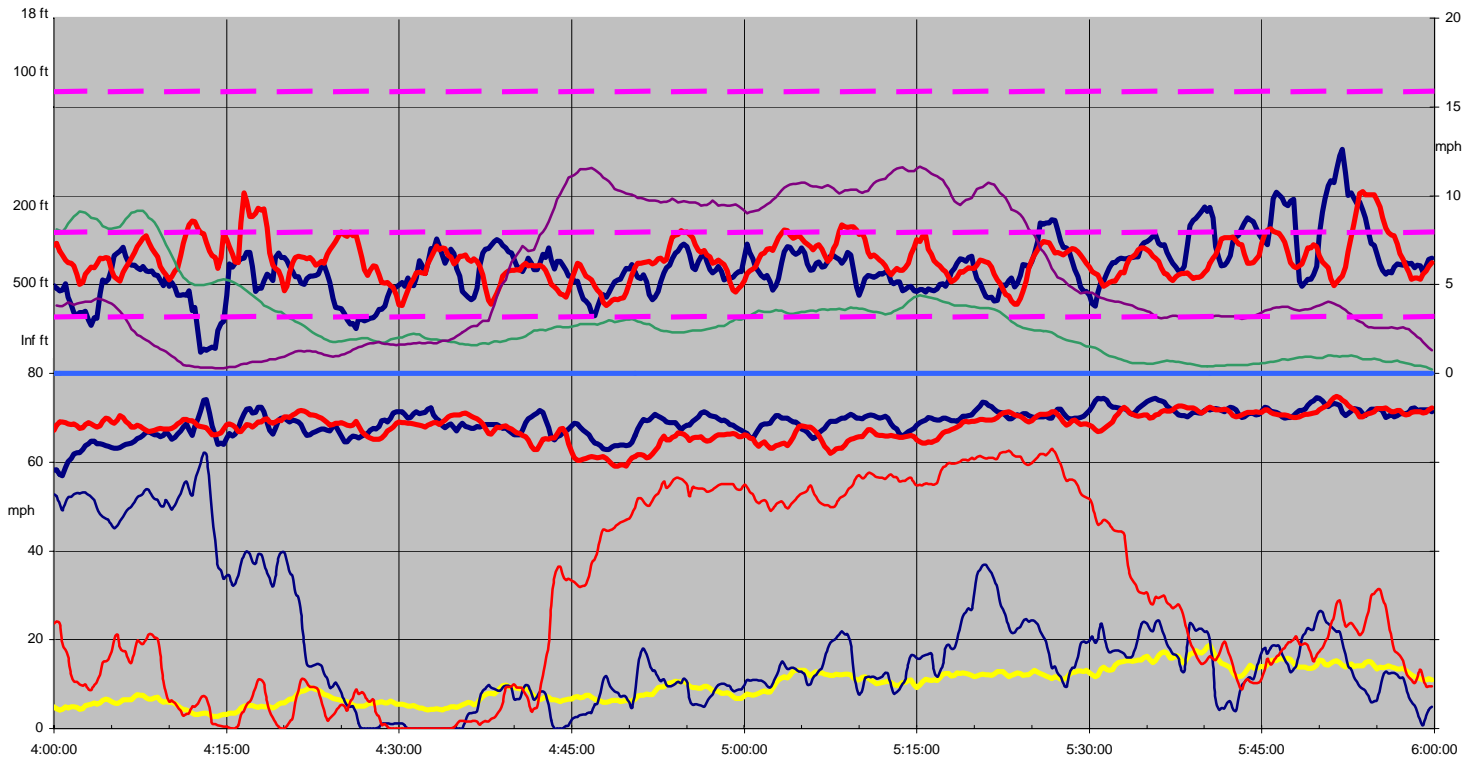

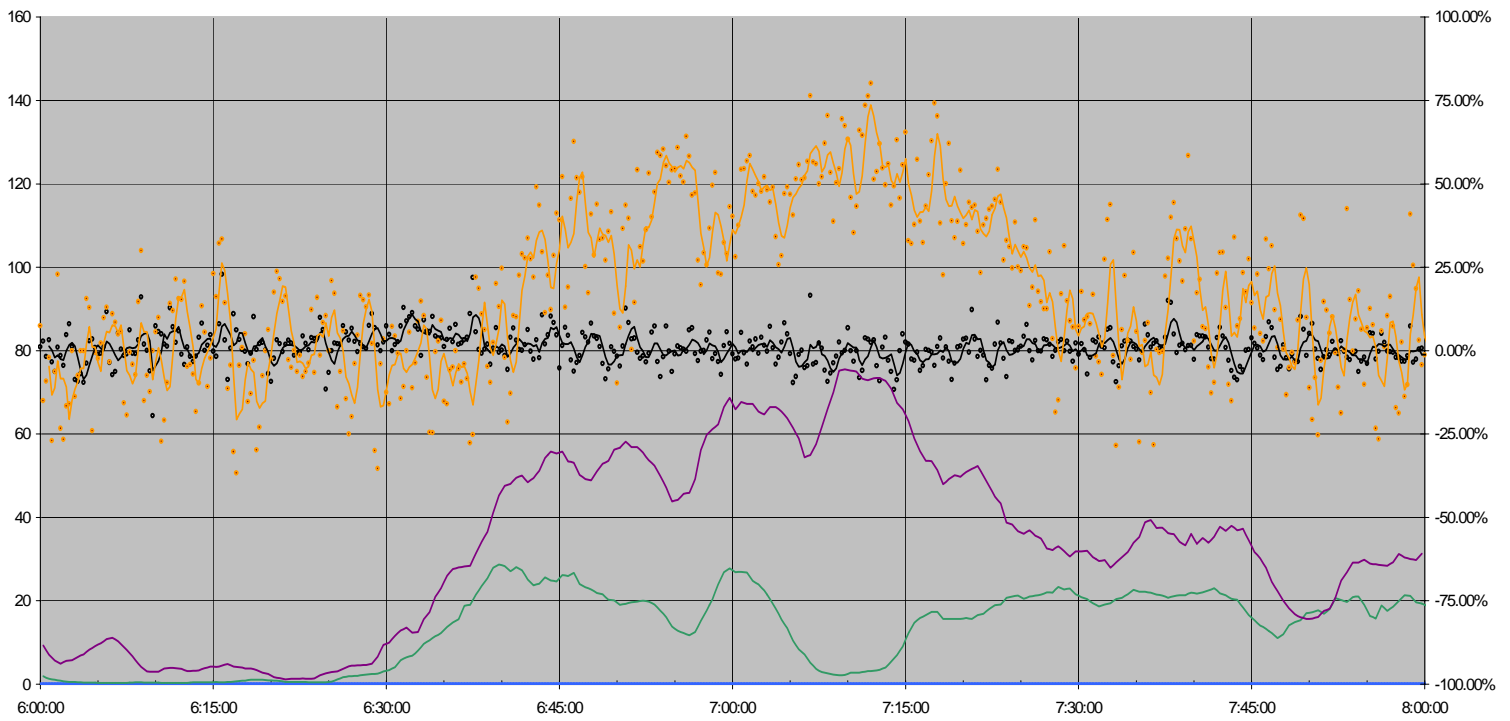

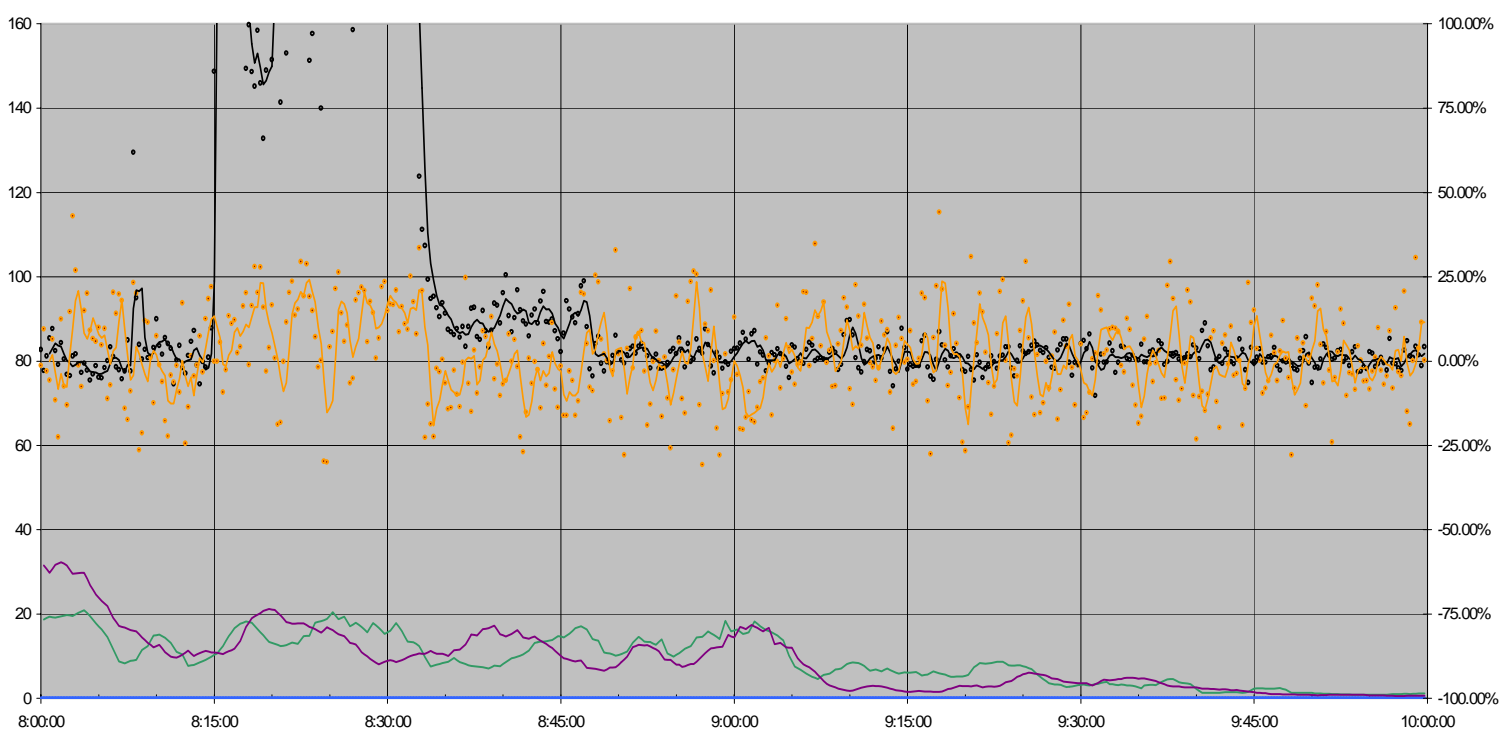
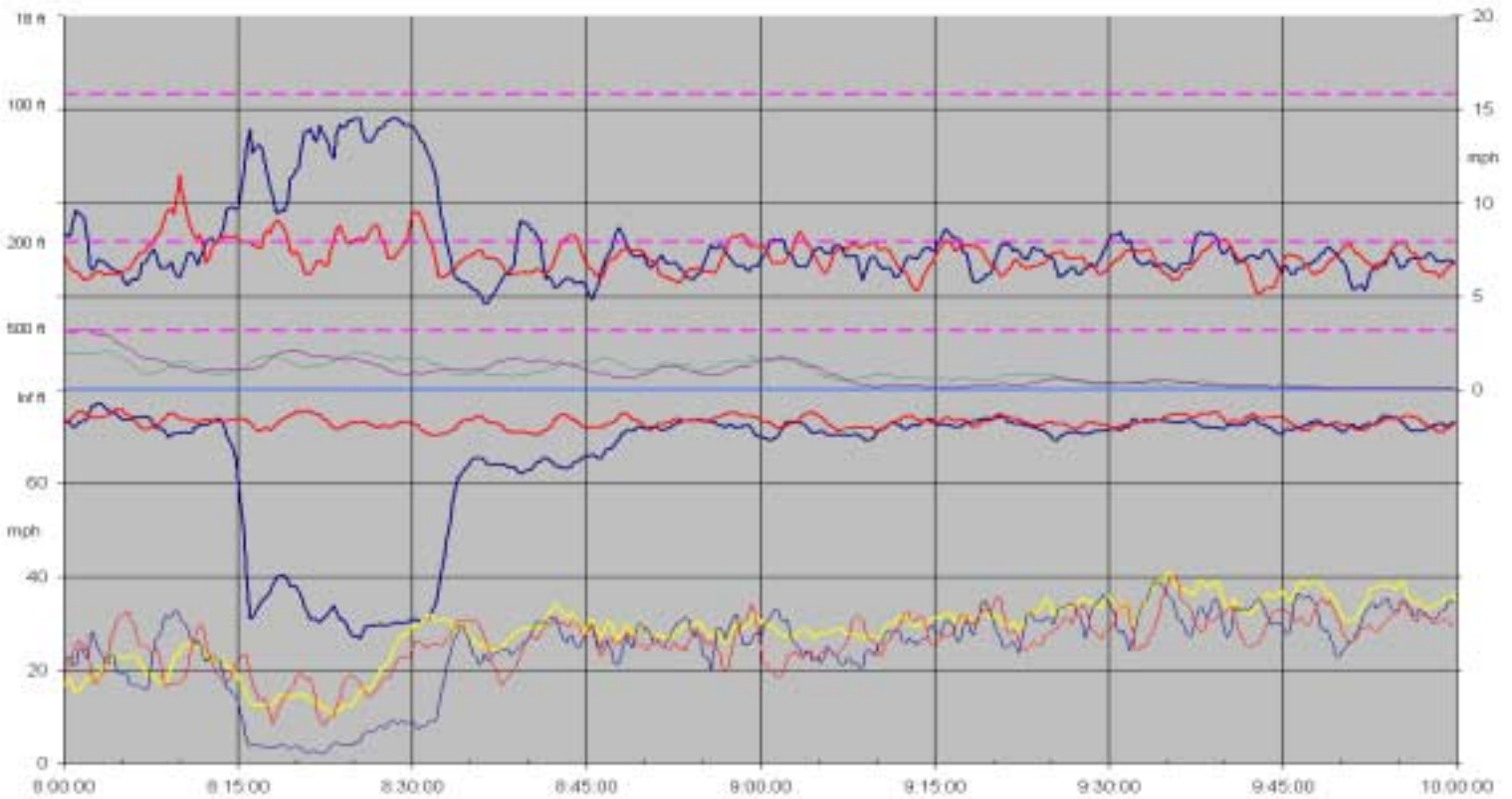



Sample traffic image

Figure 2.8.1.4. Sample traffic camera image during event. No CMS images since CMS did not actuate.

Table 2.8.1.3. Normalized differences, After-CMS sites VS Before-CMS sites, during constant message periods.

Start Time (mo/day/yr hr:min)	Period (sec)	CMS Messages	Speed (mph)			Stddev (mph)			Norm PCS (%)			Volume (Veh/Hr)			Vis (Extinction Coef)		
			BCMS	ACMS	%chg	BCMS	ACMS	%chg	BCMS	ACMS	%chg	BCMS	ACMS	%chg	BCMS	ACMS	%chg
11/16/2004 22:59	1248	DENSE FOG/ADVISE 45 MPH	67.53	65.05	-3.67	7.2	6.9	-4.17	14.91	27.85	86.79	1382	1243	-10.02	22.43	35.2	56.93
11/16/2004 23:20	1248	BLANK MESSAGE	65.36	67.17	2.77	7.76	7.88	1.55	19.78	13.4	-32.25	1021	1018	-0.28	31.04	4.04	-86.98
11/17/2004 0:38	3600	DENSE FOG/ADVISE 45 MPH	65.04	63.03	-3.09	7.36	7.08	-3.8	10.75	21.79	102.7	715	685	-4.2	19.65	39.25	99.75
11/17/2004 7:59	3600	BLANK MESSAGE	68.49	69.44	1.39	7.18	7.12	-0.84	62.56	58.64	-6.27	6803	6010	-11.66	11.88	20.36	71.38

Table 2.8.1.4. Normalized change in metrics measured during period 15 minutes after vs period 15 minutes before each message transition.

CMS TRANSITION			Speed (mph)			Stddev (mph)			Norm PCS (%)			Volume (Veh/Hr)			Vis (Extinction Coef)		
Time of Transition		CMS Message	BCMS	ACMS	%chg	BCMS	ACMS	%chg	BCMS	ACMS	%chg	BCMS	ACMS	%chg	BCMS	ACMS	%chg
11/16/2004 22:59	PRE	BLANK MESSAGE	68.98	64.62	-6.32	7.33	6.84	-6.68	23.56	19.18	-18.59	1596	1212	-24.06	5.45	46.09	745.69
	POST	DENSE FOG/ADVISE 45 MPH	67.46	62.35	-7.57	7.57	6.5	-14.13	13.24	27.64	108.76	1464	1284	-12.3	11.05	52.8	377.83
		Period Size: 300s		-2.2	-3.51	-1.34	3.27	-4.97	-7.98	-43.8	44.11	156.43	-8.27	5.94	15.49	102.75	14.56
11/16/2004 23:20	PRE	DENSE FOG/ADVISE 45 MPH	67.23	67.35	0.18	7.25	7.4	2.07	19.48	14.44	-25.87	1428	1392	-2.52	33.57	14.58	-56.57
	POST	BLANK MESSAGE	65.9	67.75	2.81	7.51	7.69	2.4	13	11.38	-12.46	1044	1164	11.49	22.37	5.19	-76.8
		Period Size: 300s		-1.98	0.59	2.62	3.59	3.92	0.32	-33.26	-21.19	18.09	-26.89	-16.38	14.38	-33.36	-64.4
11/17/2004 0:38	PRE	BLANK MESSAGE	66.75	64.19	-3.84	11.98	11.57	-3.42	12.42	5.02	-59.58	600	516	-14	6.02	45.24	651.5
	POST	DENSE FOG/ADVISE 45 MPH	63.63	63.38	-0.39	7.45	7.83	5.1	22.43	27.73	23.63	912	948	3.95	10.07	61.98	515.49
		Period Size: 300s		-4.67	-1.26	3.58	-37.81	-32.32	8.83	80.6	452.39	205.87	52	83.72	20.87	67.28	37
11/17/2004 7:59	PRE	DENSE FOG/ADVISE 45 MPH	68.11	68.7	0.87	7.6	7.05	-7.24	62.93	55.07	-12.49	7056	5196	-26.36	18.65	28.07	50.51
	POST	BLANK MESSAGE	67.88	70.15	3.34	6.64	7	5.42	67.54	57.23	-15.27	7548	5952	-21.14	18.7	31.65	69.25
		Period Size: 300s		-0.34	2.11	2.46	-12.63	-0.71	13.65	7.33	3.92	-3.17	6.97	14.55	7.08	0.27	12.75

2.8.1.3 January 08-09, 2004, Time: 10pm-8am

Synopsis:

Night fog event lasting from 10:30 PM to 6:15 AM the following morning. Correct multiple actuations of both alarm levels, except for expected blank messages during periods of visibility below 100 ft.

Files:

2004-01-08-fog-event.xls, 2004-01-08-constant-message-intervals.xls, 2004-01-08-message-transitions.xls

Narrative:

This event was characterized by a quickly moving fog front. Visibility started to degrade at 22:17. A response lag can be seen between the time the visibility fell below 500 feet at 22:27 and the CMS message appeared at 22:32.

Visibility remained very poor over the remainder of the event, and was consistently worse ACMS than BCMS. Mean speeds did not measurably change at the ACMS sites until almost 22:43, when visibility fell below 100 feet, 10 minutes after the CMS message. ACMS speeds reduced to approximately 3 mph lower than BCMS from 22:45 on. But the CMS was blank during 20:53-23:13, 23:17-23:40, and 23:52-23:55 when visibility dropped below 100 feet.

Examination the event history reveals that drivers decreased speed from approximately 70 to 60 mph as they entered the fog bank, although mean speed remained above 60 mph even during visibility below 100 ft. PCS at the ACMS sites increased from initially 10-20 mph, typical for light traffic in clear conditions, to nearly the same as the mean speed at 22:47 as visibility became worse. This implies that if an accident blocking the road was encountered, every vehicle would collide with it before they even had a chance to initiate braking. PCS at BCMS sites remained below 50% for the duration of the event, primarily due to the better visibility BCMS. PCS did not seem to correlate with the CMS message status. Standard deviation fluctuated between 5 and 10 mph BCMS and ACMS, and no obvious difference can be discerned. Focusing on the points of message transitions, the presence or non-presence of either level of CMS message showed only a small potential influence, possibly enhancing the speed reduction but having no apparent effect on standard deviation or PCS.

Figure 2.8.1.5. Time history of event in two-hour increments (series of plots below).

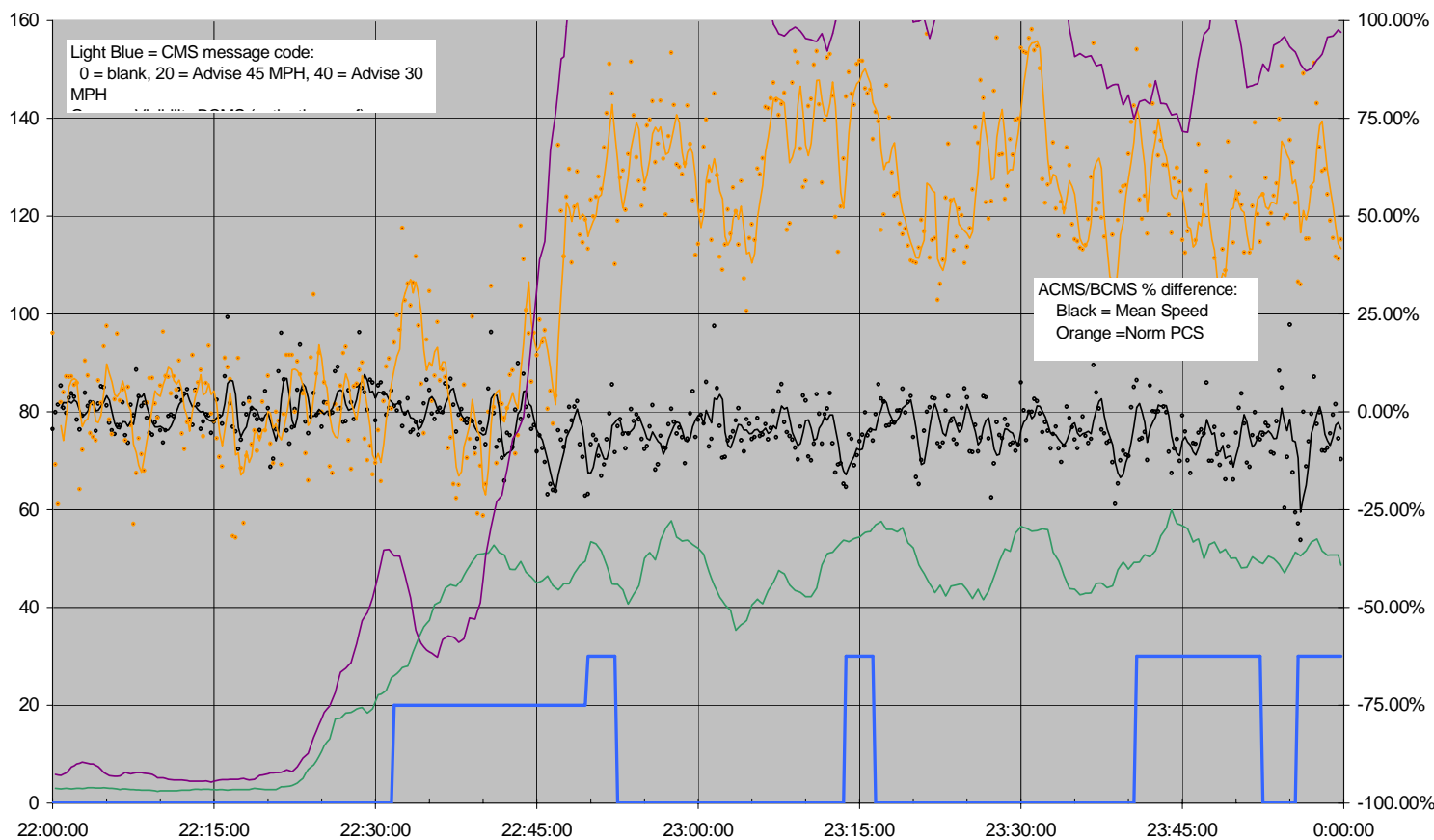
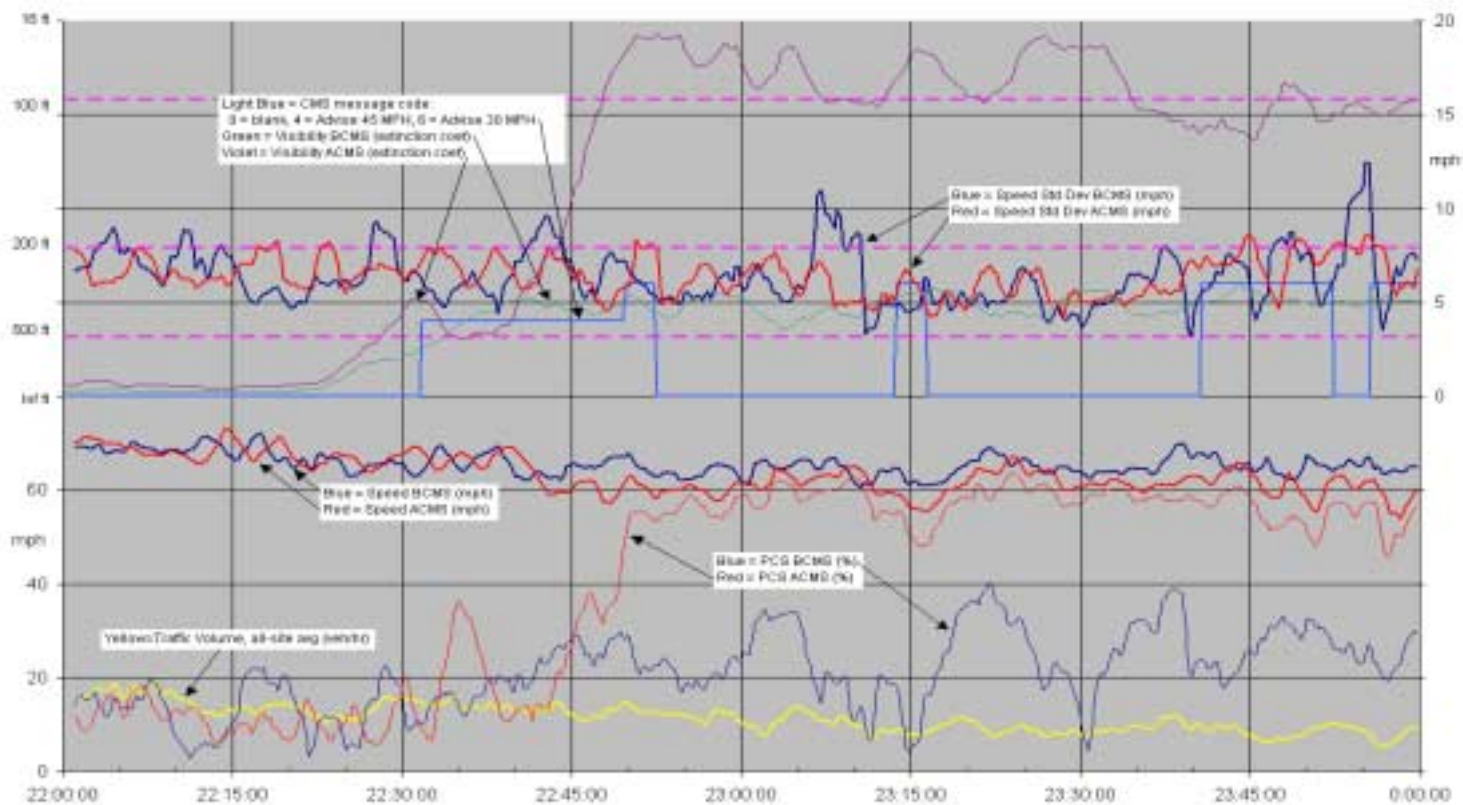

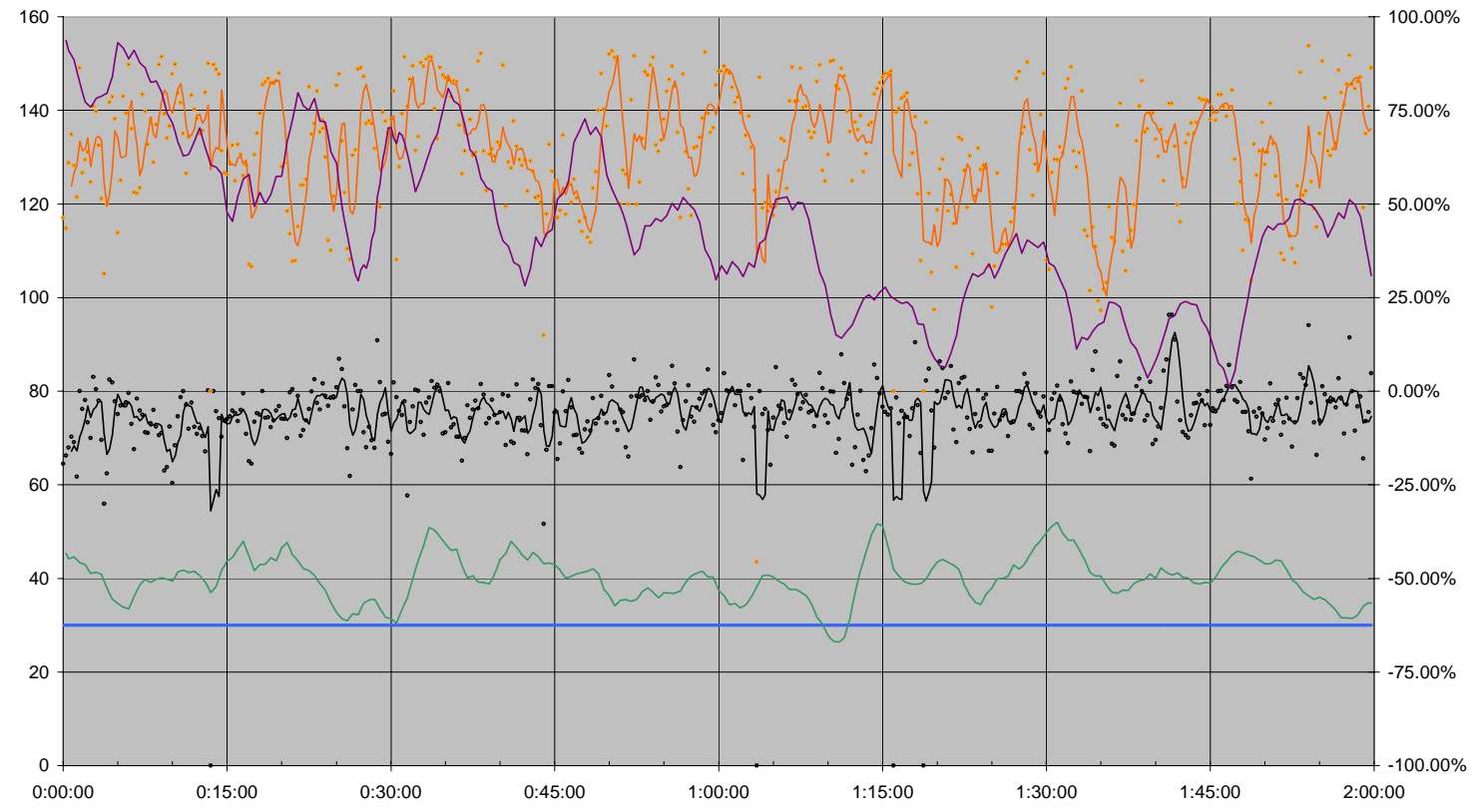
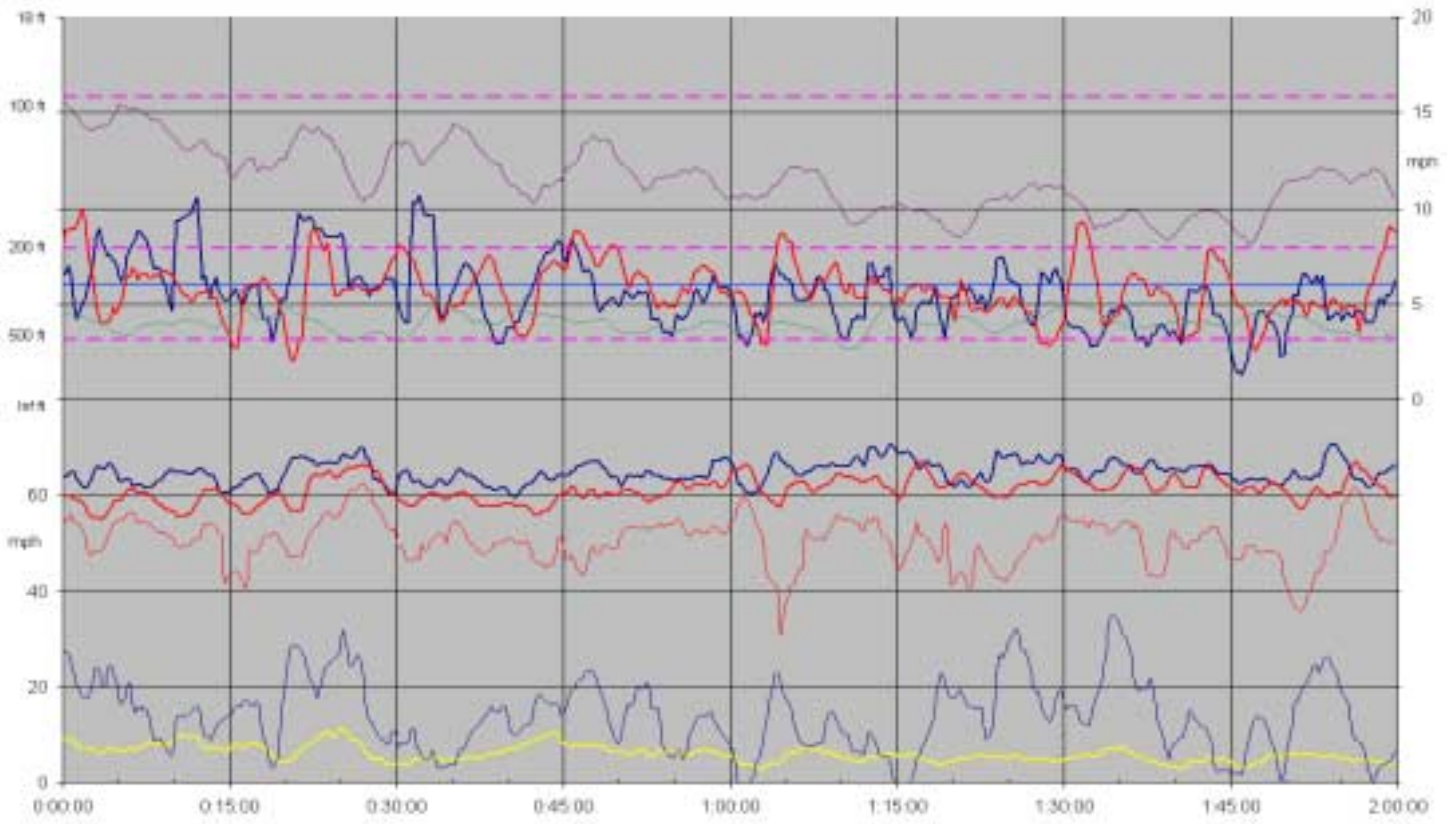

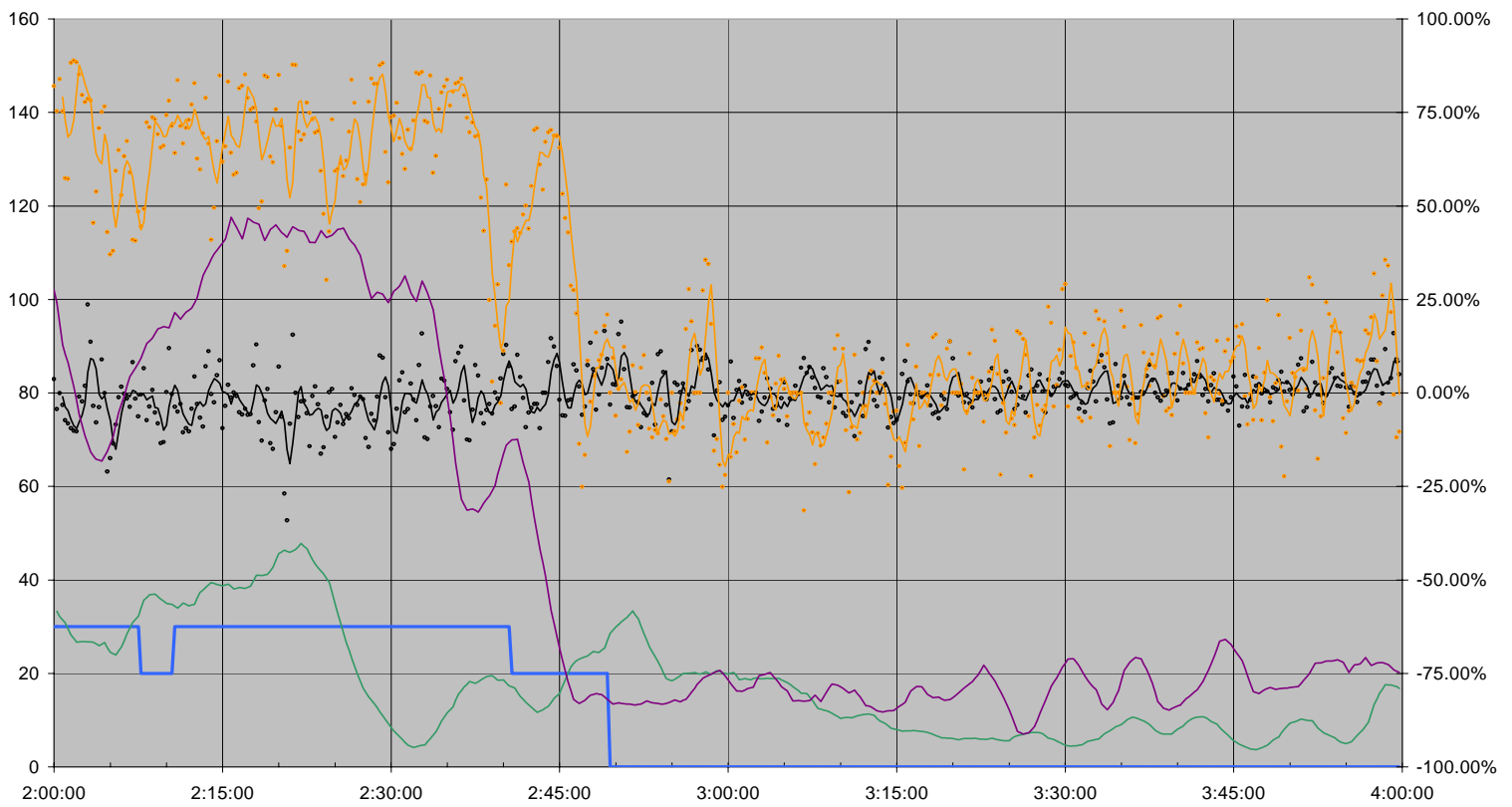

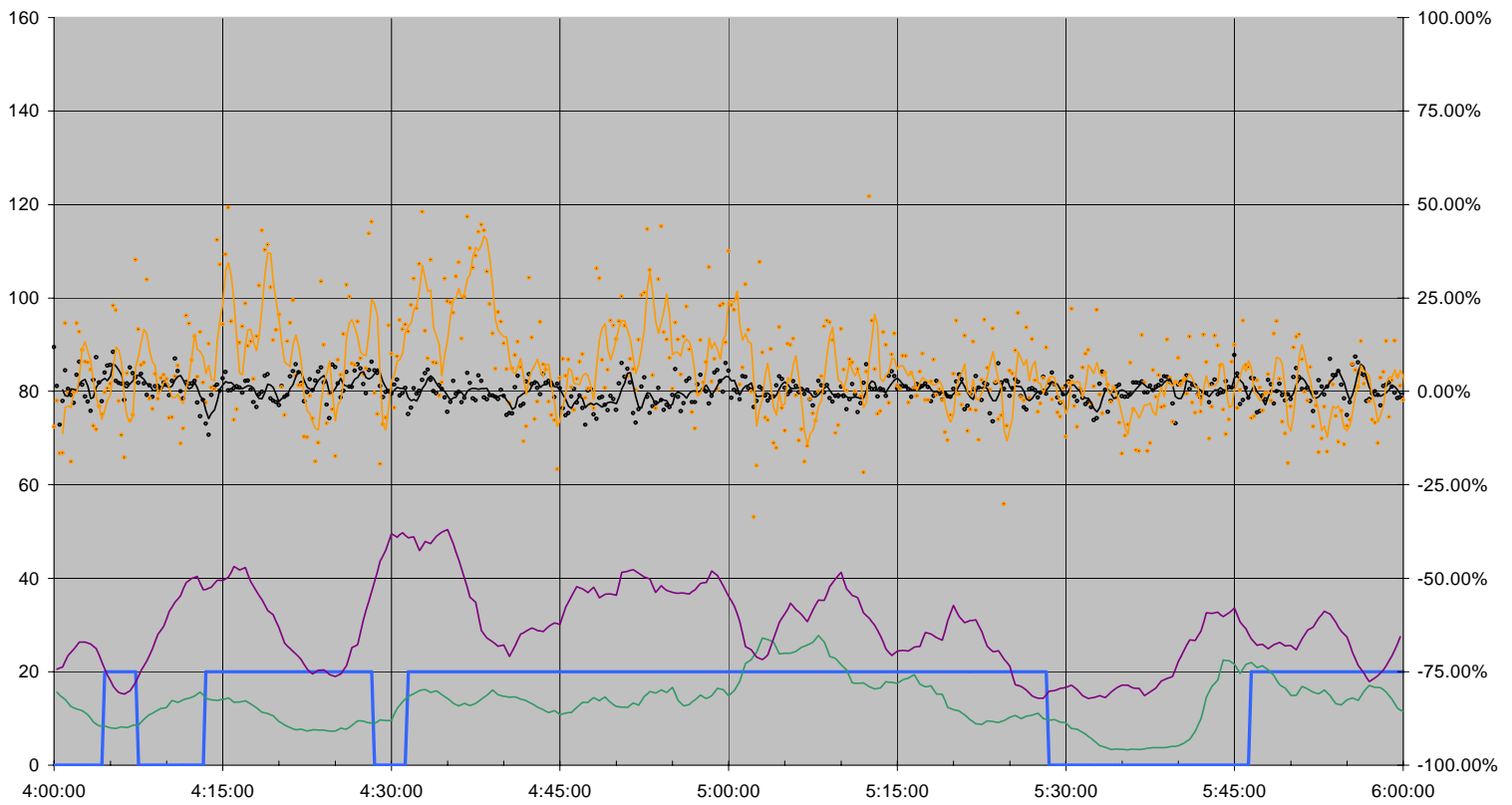
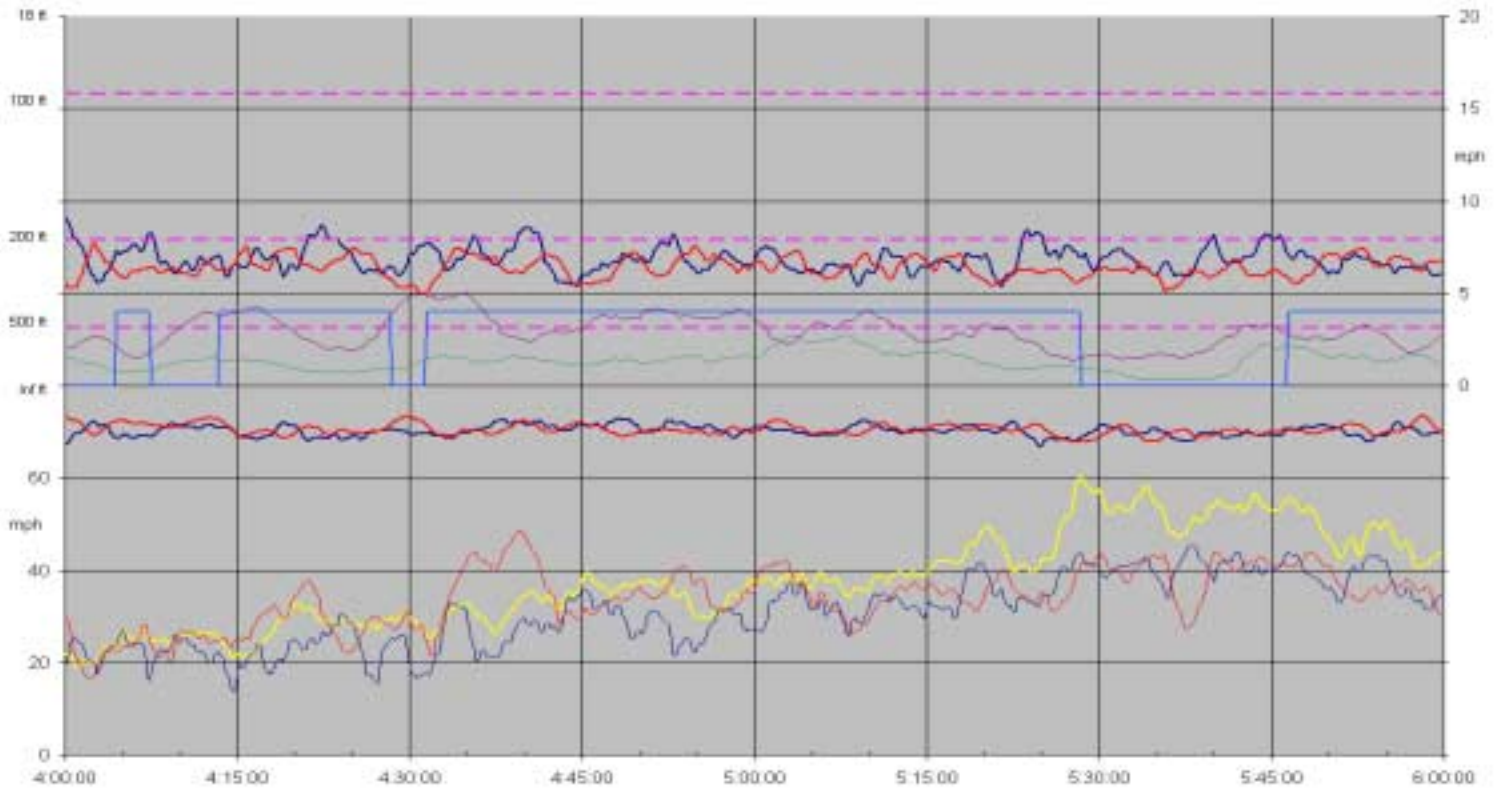

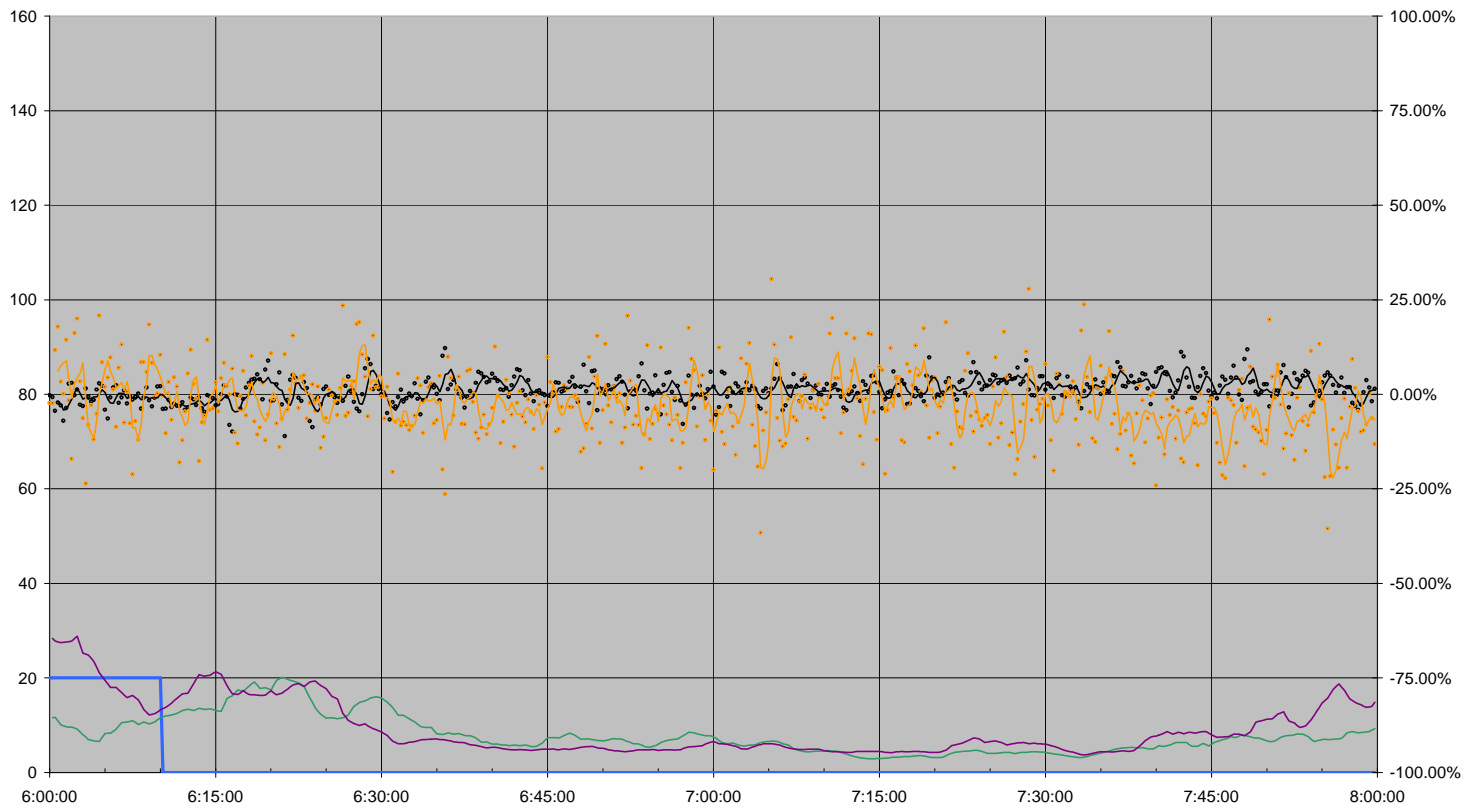
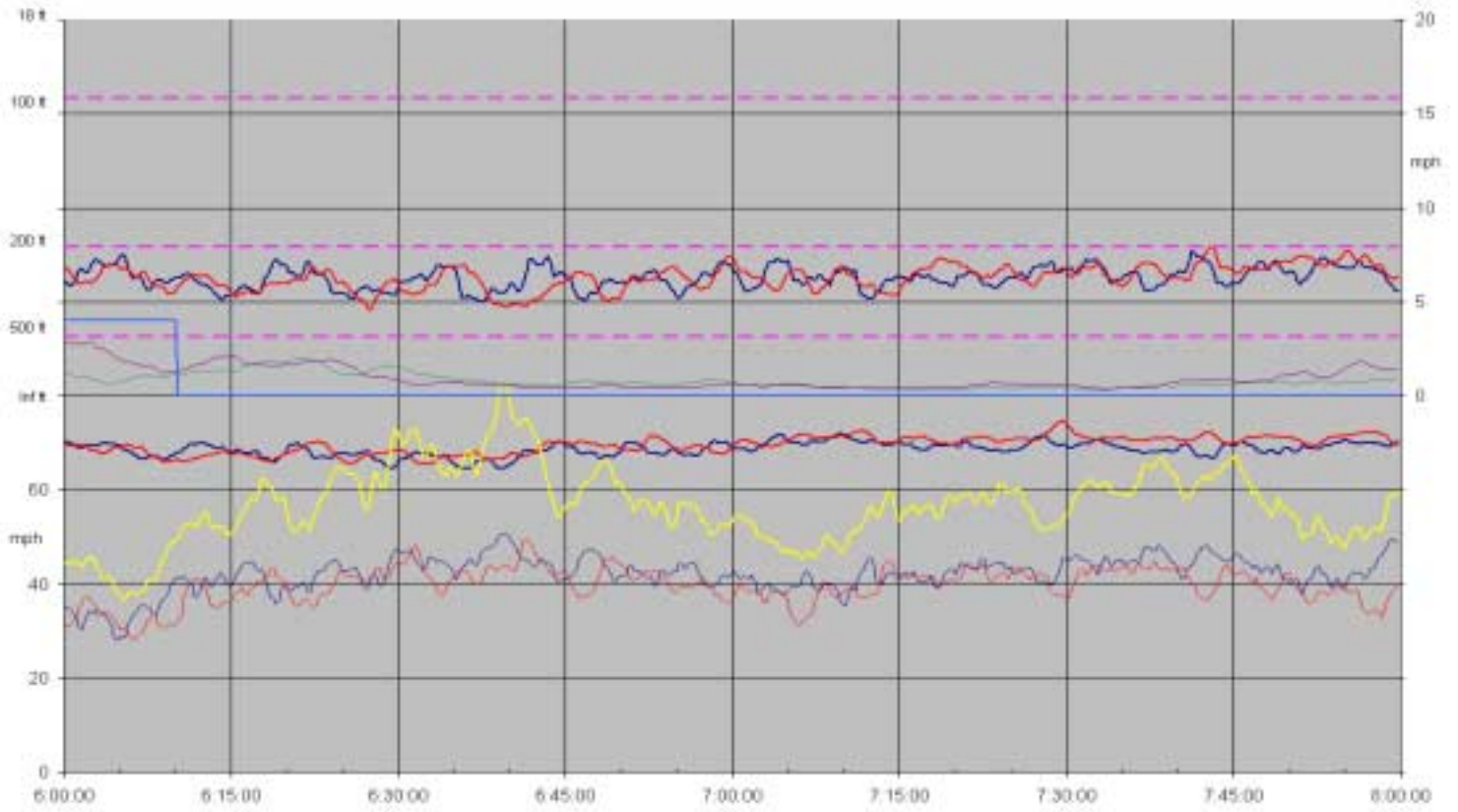



Page 1 of CMS message



Page 2 of CMS message



Sample traffic image

Figure 2.8.1.6. CMS 2-page message and sample traffic during event, from evaluation video cameras.

Table 2.8.1.5. Normalized differences, After-CMS sites VS Before-CMS sites, during constant message periods.

Start Time (mo/day/yr hr:min)	Period (sec)	CMS Messages	Speed (mph)			Stddev (mph)			Norm PCS (%)			Volume (Veh/Hr)			Vis (Extinction Coef)		
			BCMS	ACMS	%chg	BCMS	ACMS	%chg	BCMS	ACMS	%chg	BCMS	ACMS	%chg	BCMS	ACMS	%chg
1/8/2004 22:31	1079	DENSE FOG/ADVISE 45 MPH	65.22	63.84	-2.12	7.95	8.06	1.38	30.32	42.53	40.27	1705	1498	-12.13	42.6	85.63	101.01
1/8/2004 22:49	170	DENSE FOG/ADVISE 30 MPH	66.97	59.09	-11.77	7.27	9.56	31.5	37.64	90.2	139.64	1864	1292	-30.68	50.75	191.1	276.51
1/8/2004 22:52	170	BLANK MESSAGE	63.19	60.83	-3.73	6.01	6.6	9.82	35.56	96.08	170.19	1652	1567	-5.13	43.49	183.5	321.82
1/8/2004 23:13	170	DENSE FOG/ADVISE 30 MPH	63.98	55.49	-13.27	6.2	6.12	-1.29	23.28	88.62	280.67	1376	911	-33.85	53.93	182.3	238.1
1/8/2004 23:16	170	BLANK MESSAGE	61.55	60.64	-1.48	5.62	5.6	-0.36	29.39	94.63	221.98	1207	1144	-5.26	56.21	165.3	194.04
1/8/2004 23:40	710	DENSE FOG/ADVISE 30 MPH	65.08	61.35	-5.73	8.65	9.21	6.47	38.23	90.45	136.59	1009	953	-5.53	52.21	150.6	188.47
1/8/2004 23:52	190	BLANK MESSAGE	65.61	61.24	-6.66	11.58	8.73	-24.61	35.52	91.95	158.87	1232	1042	-15.38	49.13	153.5	212.52
1/8/2004 23:55	190	DENSE FOG/ADVISE 30 MPH	63.32	56.48	-10.8	8.09	8.98	11	29.79	88.38	196.68	663	587	-11.43	51.6	154.9	200.1
1/9/2004 2:07	179	DENSE FOG/ADVISE 45 MPH	65.18	63	-3.34	7.24	6.08	-16.02	6.59	66.66	911.53	804	845	5	34.73	95.33	174.49
1/9/2004 2:10	179	DENSE FOG/ADVISE 30 MPH	66.59	64.48	-3.17	7.13	7.41	3.93	6.53	77.3	1083.77	644	704	9.38	34.67	105.4	203.87
1/9/2004 2:40	530	DENSE FOG/ADVISE 45 MPH	68.75	69.12	0.54	8.72	8.1	-7.11	15.48	51.9	235.27	897	890	-0.76	17.8	24.85	39.61
1/9/2004 2:49	530	BLANK MESSAGE	68.31	68.81	0.73	8.65	9.06	4.74	14.72	14.08	-4.35	863	910	5.51	24.85	15.54	-37.46
1/9/2004 4:04	170	DENSE FOG/ADVISE 45 MPH	69.55	71.9	3.38	7.63	6.23	-18.35	38.21	37.83	-0.99	3219	3452	7.24	8.13	19.38	138.38
1/9/2004 4:07	170	BLANK MESSAGE	69.65	71.37	2.47	7.73	6.27	-18.89	31.38	35.54	13.26	2774	3219	16.03	10.22	32.37	216.73
1/9/2004 4:13	369	DENSE FOG/ADVISE 45 MPH	69.65	69.13	-0.75	7.13	7.51	5.33	29.24	45.02	53.97	2849	3141	10.27	13.43	36.57	172.3
1/9/2004 4:28	190	BLANK MESSAGE	70.33	71.89	2.22	6.6	5.46	-17.27	34.18	39.3	14.98	3373	3600	6.74	9.81	48.58	395.21
1/9/2004 4:31	190	DENSE FOG/ADVISE 45 MPH	69.33	70.17	1.21	7.78	7.53	-3.21	33.8	53.39	57.96	3183	3714	16.67	15.31	48.65	217.77
1/9/2004 5:28	1090	BLANK MESSAGE	69.59	69.77	0.26	7.45	6.34	-14.9	61.78	60.9	-1.42	6612	6199	-6.24	8.32	21.88	162.98
1/9/2004 5:46	1090	DENSE FOG/ADVISE 45 MPH	70.05	70.17	0.17	7	7.04	0.57	55.9	54.38	-2.72	5955	5202	-12.65	14.69	25.4	72.91
1/9/2004 6:10	1428	BLANK MESSAGE	67.65	67.42	-0.34	6.52	6.31	-3.22	65.85	63.64	-3.36	7528	6807	-9.58	14.65	14.23	-2.87

Table 2.8.1.6. Normalized change in metrics measured during period 15 minutes after vs period 15 minutes before each message transition.

CMS TRANSITION			Speed (mph)			Stddev (mph)			Norm PCS (%)			Volume (Veh/Hr)			Vis (Extinction Coef)		
Time of Transition	CMS Message		BCMS	ACMS	%chg	BCMS	ACMS	%chg	BCMS	ACMS	%chg	BCMS	ACMS	%chg	BCMS	ACMS	%chg
1/8/2004 22:31	PRE	BLANK MESSAGE	65.22	67.62	3.68	9.28	7.52	-18.97	25.72	23.44	-8.86	1764	1656	-6.12	19.25	44.82	132.83
	POST	DENSE FOG/ADVISE 45 MPH	65.84	65.9	0.09	7.1	7.37	3.8	21.32	42.33	98.55	1764	1776	0.68	30.94	33.59	8.56
		Period Size: 300s		0.95	-2.54	-3.46	-23.49	-1.99	28.1	-17.11	80.59	117.86	0	7.25	7.25	60.73	-25.06
1/8/2004 22:49	PRE	DENSE FOG/ADVISE 45 MPH	64.68	60.64	-6.25	7.18	7.63	6.27	36.82	76.95	108.99	1715	1376	-19.75	44.96	181.9	304.54
	POST	DENSE FOG/ADVISE 30 MPH	66.97	59.09	-11.77	7.27	9.56	31.5	37.64	90.2	139.64	1864	1292	-30.68	50.75	191.1	276.51
		Period Size: 170s		3.54	-2.56	-5.89	1.25	25.29	23.74	2.23	17.22	14.67	8.64	-6.15	-13.62	12.88	5.06
1/8/2004	PRE	DENSE FOG/ADVISE 30 MPH	66.97	59.09	-11.77	7.27	9.56	31.5	37.64	90.2	139.64	1864	1292	-30.68	50.75	191.1	276.51

22:52	POST	BLANK MESSAGE	63.19	60.83	-3.73	6.01	6.6	9.82	35.56	96.08	170.19	1652	1567	-5.13	43.49	183.5	321.82
	Period Size: 170s		-5.64	2.94	9.1	-17.33	-30.96	-16.49	-5.53	6.52	12.75	-11.36	21.31	36.86	-14.31	-3.99	12.03
1/8/2004 23:13	PRE	BLANK MESSAGE	61.6	58.9	-4.38	4.98	6.1	22.49	11.87	91.29	669.08	741	635	-14.29	47.43	166.8	251.61
	POST	DENSE FOG/ADVISE 30 MPH	63.98	55.49	-13.27	6.2	6.12	-1.29	23.28	88.62	280.67	1376	911	-33.85	53.93	182.3	238.1
	Period Size: 170s		3.86	-5.79	-9.29	24.5	0.33	-19.41	96.12	-2.92	-50.5	85.71	43.33	-22.82	13.7	9.34	-3.84
1/8/2004 23:16	PRE	DENSE FOG/ADVISE 30 MPH	63.98	55.49	-13.27	6.2	6.12	-1.29	23.28	88.62	280.67	1376	911	-33.85	53.93	182.3	238.1
	POST	BLANK MESSAGE	61.55	60.64	-1.48	5.62	5.6	-0.36	29.39	94.63	221.98	1207	1144	-5.26	56.21	165.3	194.04
	Period Size: 170s		-3.8	9.28	13.6	-9.35	-8.5	0.95	26.25	6.78	-15.42	-12.31	25.58	43.21	4.23	-9.36	-13.03
1/8/2004 23:40	PRE	BLANK MESSAGE	66.78	61.84	-7.4	8.03	6.57	-18.18	50.01	93.56	87.08	1356	1284	-5.31	44.73	145.6	225.6
	POST	DENSE FOG/ADVISE 30 MPH	65.8	62.98	-4.29	8.04	8.46	5.22	29.36	91.04	210.08	1128	996	-11.7	52.69	142.9	171.21
	Period Size: 300s		-1.47	1.84	3.36	0.12	28.77	28.61	-41.29	-2.69	65.75	-16.81	-22.43	-6.75	17.8	-1.88	-16.7
1/8/2004 23:52	PRE	DENSE FOG/ADVISE 30 MPH	65.21	60.62	-7.04	8.99	9.5	5.67	43.4	91.64	111.15	928	1118	20.41	49.76	149.3	200.06
	POST	BLANK MESSAGE	65.61	61.24	-6.66	11.58	8.73	-24.61	35.52	91.95	158.87	1232	1042	-15.38	49.13	153.5	212.52
	Period Size: 190s		0.61	1.02	0.41	28.81	-8.11	-28.66	-18.16	0.34	22.6	32.65	-6.78	-29.73	-1.27	2.83	4.15
1/8/2004 23:55	PRE	BLANK MESSAGE	65.61	61.24	-6.66	11.58	8.73	-24.61	35.52	91.95	158.87	1232	1042	-15.38	49.13	153.5	212.52
	POST	DENSE FOG/ADVISE 30 MPH	63.32	56.48	-10.8	8.09	8.98	11	29.79	88.38	196.68	663	587	-11.43	51.6	154.9	200.1
	Period Size: 190s		-3.49	-7.77	-4.44	-30.14	2.86	47.24	-16.13	-3.88	14.61	-46.15	-43.64	4.68	5.03	0.85	-3.97
1/9/2004 2:07	PRE	DENSE FOG/ADVISE 30 MPH	69.07	64.93	-5.99	6.63	6.88	3.77	9.1	67.28	639.34	784	744	-5.13	25.86	86.34	233.87
	POST	DENSE FOG/ADVISE 45 MPH	65.18	63	-3.34	7.24	6.08	-16.02	6.59	66.66	911.53	804	845	5	34.73	95.33	174.49
	Period Size: 179s		-5.63	-2.97	2.82	9.2	-11.63	-19.07	-27.58	-0.92	36.82	2.56	13.51	10.68	34.3	10.41	-17.79
1/9/2004 2:10	PRE	DENSE FOG/ADVISE 45 MPH	65.18	63	-3.34	7.24	6.08	-16.02	6.59	66.66	911.53	804	845	5	34.73	95.33	174.49
	POST	DENSE FOG/ADVISE 30 MPH	66.59	64.48	-3.17	7.13	7.41	3.93	6.53	77.3	1083.77	644	704	9.38	34.67	105.4	203.87
	Period Size: 179s		2.16	2.35	0.18	-1.52	21.88	23.76	-0.91	15.96	17.03	-20	-16.67	4.17	-0.17	10.51	10.7
1/9/2004 2:40	PRE	DENSE FOG/ADVISE 30 MPH	64.79	62.95	-2.84	9.43	6.85	-27.36	6.68	60.92	811.98	708	780	10.17	16.91	62.32	268.54
	POST	DENSE FOG/ADVISE 45 MPH	68.44	69.55	1.62	9.15	8.55	-6.56	18.56	63.11	240.03	996	1032	3.61	14.58	33.17	127.5
	Period Size: 300s		5.63	10.48	4.59	-2.97	24.82	28.64	177.84	3.59	-62.71	40.68	32.31	-5.95	-13.78	-46.77	-38.27
1/9/2004 2:49	PRE	DENSE FOG/ADVISE 45 MPH	68.6	68.76	0.23	7.97	6.95	-12.8	9.15	40.1	338.25	660	720	9.09	20.23	14.37	-28.97
	POST	BLANK MESSAGE	70.44	70.37	-0.1	8.51	9.03	6.11	12.22	13.3	8.84	1020	1080	5.88	28.96	13.69	-52.73
	Period Size: 300s		2.68	2.34	-0.33	6.78	29.93	21.68	33.55	-66.83	-75.17	54.55	50	-2.94	43.15	-4.73	-33.45
1/9/2004 4:04	PRE	BLANK MESSAGE	71.62	71.9	0.39	6.67	6.76	1.35	31.35	35.62	13.62	2435	2795	14.78	11.25	20.74	84.36
	POST	DENSE FOG/ADVISE 45 MPH	69.55	71.9	3.38	7.63	6.23	-18.35	38.21	37.83	-0.99	3219	3452	7.24	8.13	19.38	138.38
	Period Size: 170s		-2.89	0	2.98	14.39	-7.84	-19.44	21.88	6.2	-12.86	32.17	23.48	-6.57	-27.73	-6.56	29.3
1/9/2004 4:07	PRE	DENSE FOG/ADVISE 45 MPH	69.55	71.9	3.38	7.63	6.23	-18.35	38.21	37.83	-0.99	3219	3452	7.24	8.13	19.38	138.38
	POST	BLANK MESSAGE	69.65	71.37	2.47	7.73	6.27	-18.89	31.38	35.54	13.26	2774	3219	16.03	10.22	32.37	216.73
	Period Size: 170s		0.14	-0.74	-0.88	1.31	0.64	-0.66	-17.87	-6.05	14.39	-13.82	-6.75	8.2	25.71	67.03	32.87
1/9/2004	PRE	BLANK MESSAGE	71.08	72.45	1.93	7.02	6.24	-11.11	33.56	37.42	11.5	2952	3480	17.89	12.7	37.64	196.38

Evaluation of Caltrans Automated Warning System

Analysis of Driver Response

4:13	POST	DENSE FOG/ADVISE 45 MPH	69.7	69.21	-0.7	7.38	7.59	2.85	30.54	42.77	40.05	2700	2820	4.44	14	38.33	173.79
	Period Size: 300s		-1.94	-4.47	-2.58	5.13	21.63	15.7	-9	14.3	25.6	-8.54	-18.97	-11.4	10.24	1.83	-7.62
1/9/2004 4:28	PRE	DENSE FOG/ADVISE 45 MPH	68.87	71.21	3.4	7.06	6.2	-12.18	33.77	41.14	21.82	3107	3600	15.85	8.38	35.15	319.45
	POST	BLANK MESSAGE	70.33	71.89	2.22	6.6	5.46	-17.27	34.18	39.3	14.98	3373	3600	6.74	9.81	48.58	395.21
	Period Size: 190s		2.12	0.95	-1.14	-6.52	-11.94	-5.8	1.21	-4.47	-5.62	8.54	0	-7.87	17.06	38.21	18.06
1/9/2004 4:31	PRE	BLANK MESSAGE	70.33	71.89	2.22	6.6	5.46	-17.27	34.18	39.3	14.98	3373	3600	6.74	9.81	48.58	395.21
	POST	DENSE FOG/ADVISE 45 MPH	69.33	70.17	1.21	7.78	7.53	-3.21	33.8	53.39	57.96	3183	3714	16.67	15.31	48.65	217.77
	Period Size: 190s		-1.42	-2.39	-0.98	17.88	37.91	16.99	-1.11	35.85	37.38	-5.62	3.16	9.3	56.07	0.14	-35.83
1/9/2004 5:28	PRE	DENSE FOG/ADVISE 45 MPH	68.83	68.89	0.09	8.27	6.24	-24.55	53.01	56.76	7.07	5676	5496	-3.17	10.07	16.3	61.87
	POST	BLANK MESSAGE	69.97	69.87	-0.14	7.65	6.94	-9.28	60.79	60.09	-1.15	6696	6228	-6.99	8.15	15.49	90.06
	Period Size: 300s		1.66	1.42	-0.23	-7.5	11.22	20.23	14.68	5.87	-7.68	17.97	13.32	-3.94	-19.07	-4.97	17.42
1/9/2004 5:46	PRE	BLANK MESSAGE	69.42	69.93	0.73	7.83	6.08	-22.35	62.98	62.91	-0.11	6720	6324	-5.89	15.83	30.16	90.52
	POST	DENSE FOG/ADVISE 45 MPH	70.83	70.77	-0.08	7.02	7.1	1.14	57.64	58.22	1.01	6288	5568	-11.45	18.88	26.97	42.85
	Period Size: 300s		2.03	1.2	-0.81	-10.34	16.78	30.25	-8.48	-7.46	1.12	-6.43	-11.95	-5.91	19.27	-10.58	-25.02
1/9/2004 6:10	PRE	DENSE FOG/ADVISE 45 MPH	67.65	66.86	-1.17	6.83	6.25	-8.49	50.67	52.31	3.24	5112	4704	-7.98	9.98	14.28	43.09
	POST	BLANK MESSAGE	68.77	67.43	-1.95	6.4	6.12	-4.38	62.22	59.65	-4.13	6708	6120	-8.77	12.82	19.09	48.91
	Period Size: 300s		1.66	0.85	-0.79	-6.3	-2.08	4.5	22.79	14.03	-7.14	31.22	30.1	-0.85	28.46	33.68	4.07

2.8.1.4 March 08, 2004, Time: 6am-8am**Synopsis:**

Light foggy morning, single activation after eight minute delay. Typical of a light fog event.

Files:

2004-03-08-fog-event.xls, 2004-03-08-constant-message-intervals.xls, 2004-03-08-message-transitions.xls

Narrative:

Conditions first met for activation at 6:17 AM. CMS message displayed at 6:25. 1-2 mph decrease in speed during low visibility period at both the BCMS and ACMS sites – no significant difference. PCS was approximately 40 mph for the duration of event, independent of visibility or CMS. Speed standard deviation almost identical ACMS and BCMS at 5-7 mph. CMS advised to reduce speed to 45 mph, drivers continued at 70+ mph mean speed for duration of event. No indication that the CMS had an incremental effect beyond the natural response of the drivers to the visibility reduction.

Figure 2.8.1.7. Time history of event in two-hour increments (series of plots below).

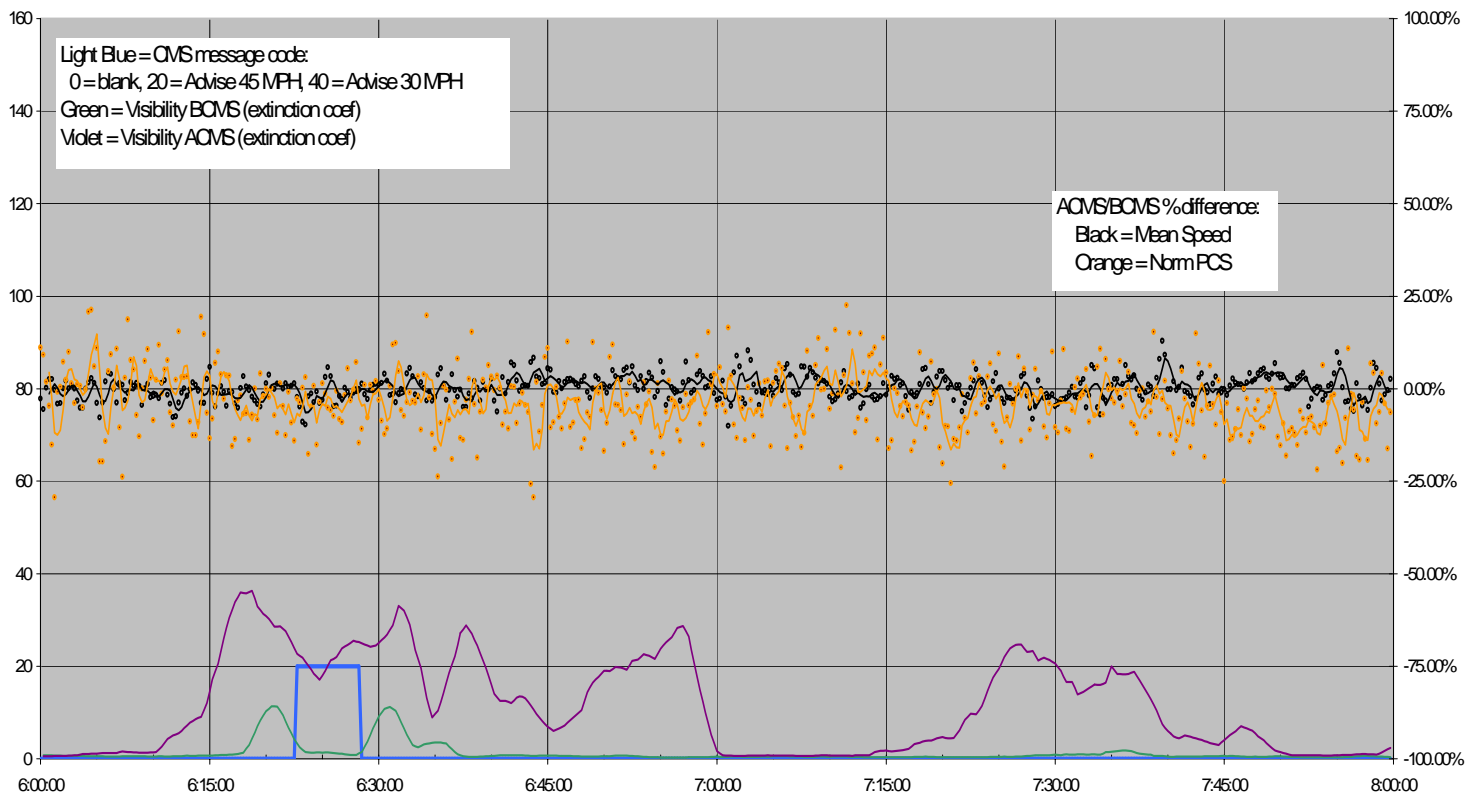
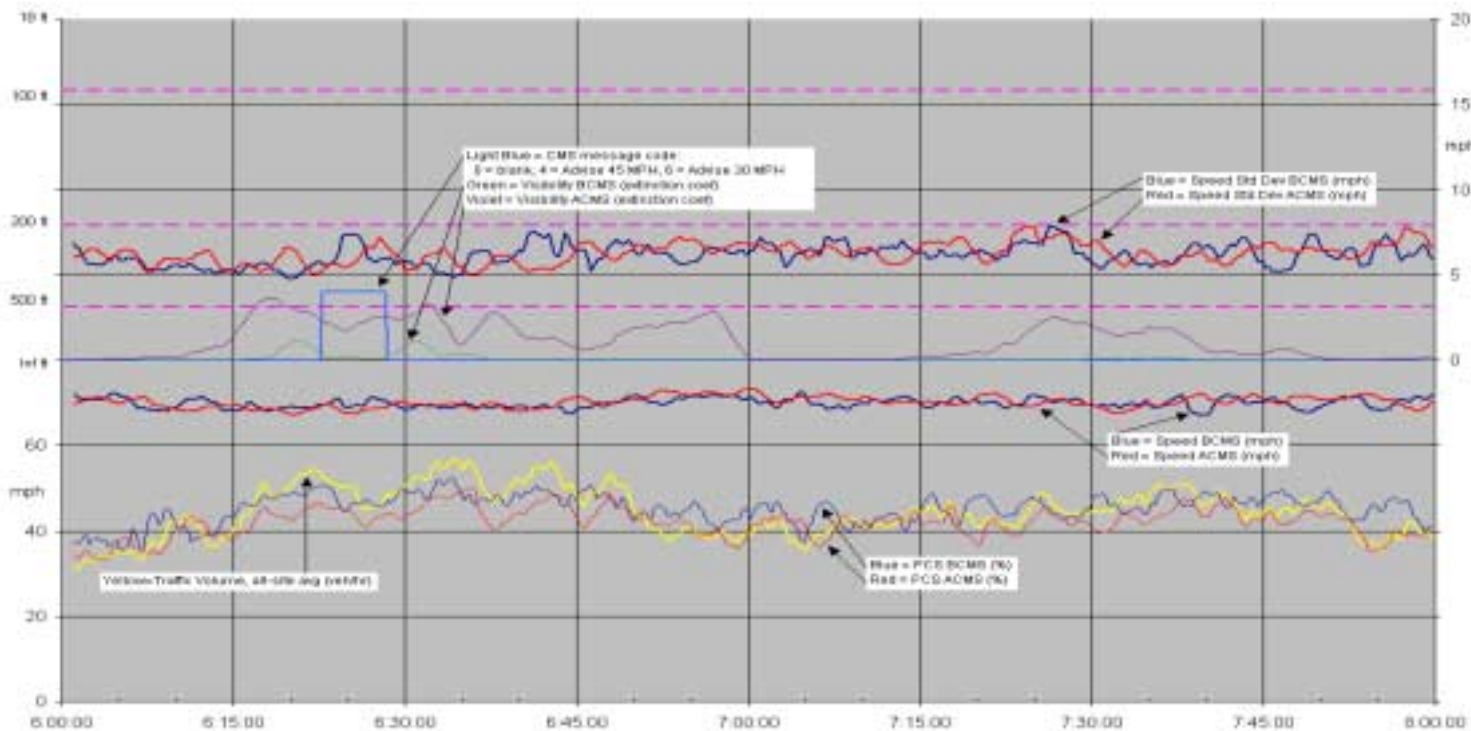



Page 1 of CMS message



Page 2 of CMS message



Sample traffic image

Figure 2.8.1.8. CMS 2-page message and sample traffic during event, from evaluation video cameras.

Table 2.8.1.7. Normalized differences, After-CMS sites VS Before-CMS sites, during constant message periods.

Start Time (mo/day/yr hr:min)	Period (sec)	CMS Messages	Speed (mph)			Stddev (mph)			Norm PCS (%)			Volume (Veh/Hr)			Vis (Extinction Coef)		
			BCMS	ACMS	%chg	BCMS	ACMS	%chg	BCMS	ACMS	%chg	BCMS	ACMS	%chg	BCMS	ACMS	%chg
3/8/2004 6:22	350	DENSE FOG/ADVISE 45 MPH	69.77	68.49	-1.83	6.85	6.45	-5.84	71.99	66.23	-8	4443	7344	65.28	1.65	22.56	1267.27
3/8/2004 6:28	350	BLANK MESSAGE	69.41	69.61	0.29	5.98	6.06	1.34	73.72	69.97	-5.09	4577	8167	78.43	6.08	22.85	275.82

Table 2.8.1.8. Normalized change in metrics measured during period 15 minutes after vs period 15 minutes before each message transition.

CMS TRANSITION			Speed (mph)			Stddev (mph)			Norm PCS (%)			Volume (Veh/Hr)			Vis (Extinction Coef)		
Time of Transition		CMS Message	BCMS	ACMS	%chg	BCMS	ACMS	%chg	BCMS	ACMS	%chg	BCMS	ACMS	%chg	BCMS	ACMS	%chg
3/8/2004 6:22	PRE	BLANK MESSAGE	68.7	68.4	-0.44	5.55	6.03	8.65	72.73	67.29	-7.48	4536	7680	69.31	6.88	26.94	291.57
	POST	DENSE FOG/ADVISE 45 MPH	69.69	68.17	-2.18	7.01	6.56	-6.42	73.08	66.58	-8.89	4500	7344	63.2	1.72	22.2	1190.7
		Period Size: 300s		1.44	-0.34	-1.75	26.31	8.79	-13.87	0.48	-1.06	-1.53	-0.79	-4.38	-3.61	-75	-17.59
3/8/2004 6:28	PRE	DENSE FOG/ADVISE 45 MPH	70.07	68.36	-2.44	6.93	6.54	-5.63	70.8	66.23	-6.45	4368	7332	67.86	1.38	23.52	1604.35
	POST	BLANK MESSAGE	69.75	69.83	0.11	6.03	6.17	2.32	72.01	68.11	-5.42	4404	7872	78.75	6.75	24.1	257.04
		Period Size: 300s		-0.46	2.15	2.62	-12.99	-5.66	8.42	1.71	2.84	1.11	0.82	7.36	6.49	389.13	2.47

2.8.1.5 December 16-17, 2004, Time: 8pm-12pm

Synopsis:

Example of a major fog event spanning night and day. CMS activated continuously from 9:10 PM through 10:53 AM the following morning. Heavy fog conditions with visibility dropping to under 100ft intermittently.

Files:

2004-12-16-fog-event.xls, 2004-12-16-constant-message-intervals.xls, 2004-12-16-message-transitions.xls

Narrative:

Conditions first met for activation at 9:04 PM. CMS message displayed at 9:10PM. From 9:09 to 9:17, visibility dropped below the CMS activation threshold, which resulted in a blank CMS from 9:16-9:22. But fog increased abruptly at 9:17 and by 9:22 visibility was very poor, but the message was still blank. Illustrative of the problems with the system activation lag. Lag problem was apparent during all other CMS transitions during this event.

Period between 10:50 PM and 11:00 PM interesting since it shows the drift of a dense fog bank from the BCMS to the ACMS sites (a distance of 1.2 miles) in approximately six minutes, approximately 12 mph. Volume was still reasonably high (10-20 vehicles per minute) at this time. Speed remained lower throughout at the ACMS sites, probably because the fog was moving generally with the traffic.

2-4 mph decrease in speed at site with lower visibility, independent of CMS activation. Usually this was the ACMS site, but note period 11:15 PM – 11:25 PM, during which visibility at BCMS site was worse than ACMS; speeds ACMS were as much as 20 mph faster, despite display of message.

From midnight to 1:00 AM, visibility was notably worse BCMS. CMS was blank. Speed BCMS dropped to 50-55 mph, while speeds ACMS remained 60-65. As soon as drivers progressed to an area of slightly improved visibility, they increased speed by 10 mph despite encountering the warning message advising 45 mph. PCS was much higher BCMS than ACMS due to the considerably worse visibility. It appears that drivers slow somewhat in fog, but not nearly enough to correct for the increased following and site distance needed to complete a safe emergency stop.

From 3:52 AM to 4:08 AM, and 8:45 AM to 9:10 AM, visibility was below 100 ft (extinction coef > 160). CMS message remained "ADVISE 45 MPH" due to changes for 2004-05 fog season, making this message the standard warning for all levels of fog. Note that for a visibility distance of 100 ft (one second at 66 mph), the required traffic speed to assure PCS = 0 mph is actually 31.3 mph. However, mean speed remained above 60 mph at both sites.

From 4:00 AM to 4:15 AM ACMS speed dropped 10 mph below BCMS but PCS was 55 to 60 mph ACMS, and approximately 10 mph lower BCMS. Traffic volume was very low. Examination of individual vehicle records

verified that under these conditions, infrequent vehicle platoons tended to travel in tightly spaced platoons (probably to keep each other's tail lights in range) but at dangerous speeds for their separation.

PCS prior to and after the event was approximately 10-15 mph, while it increased to nearly the mean speed for duration of event. Speed standard deviation remained at approximately 6 mph for the duration of the event, and never left the range of 5-10 mph before, during or after the event, independent of the CMS status. As with most other events, mean speeds remained 60-65 mph even during dense fog, with no clear evidence of influence by CMS message.

Figure 2.8.1.9. Time history of event in two-hour increments (series of plots below).

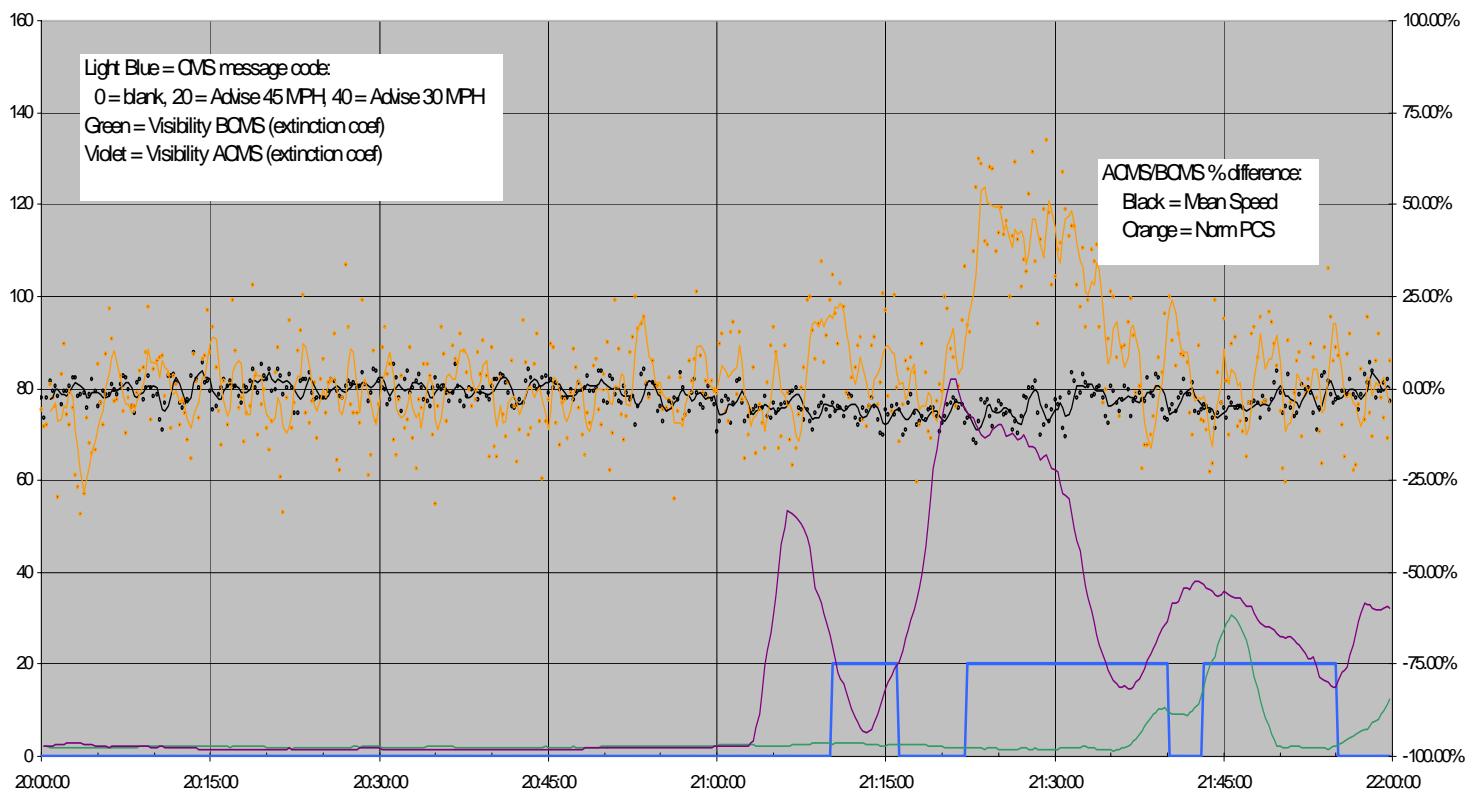
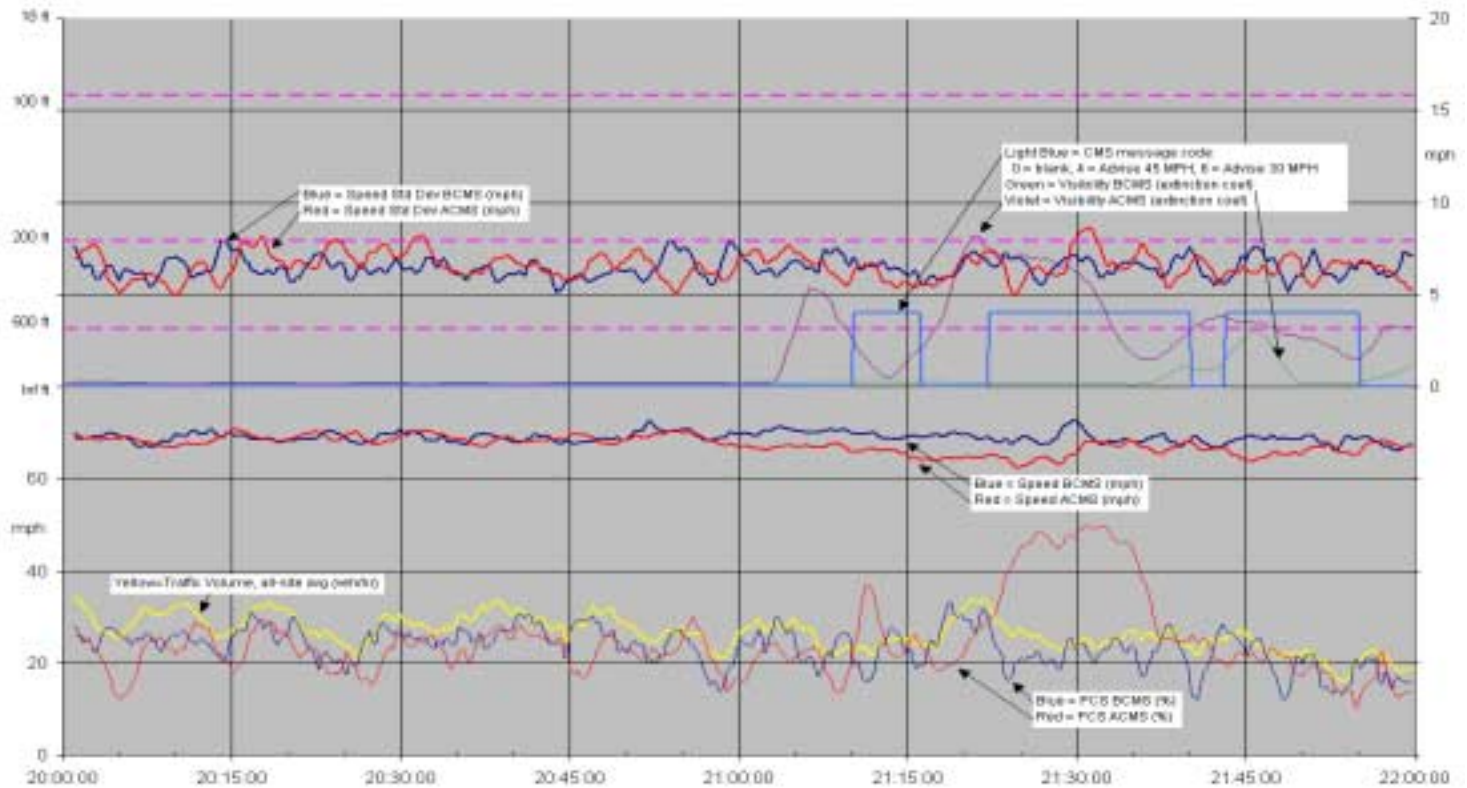

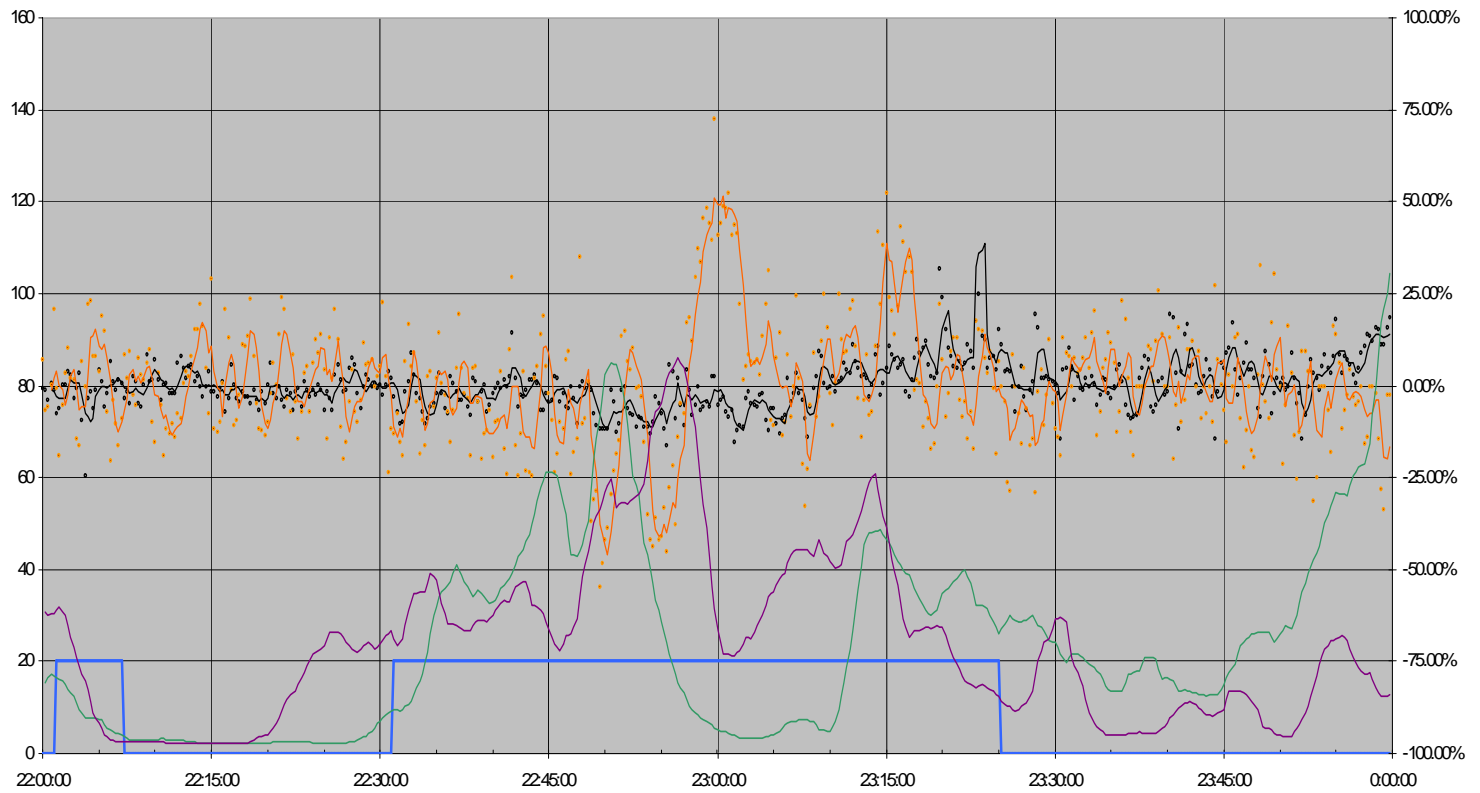
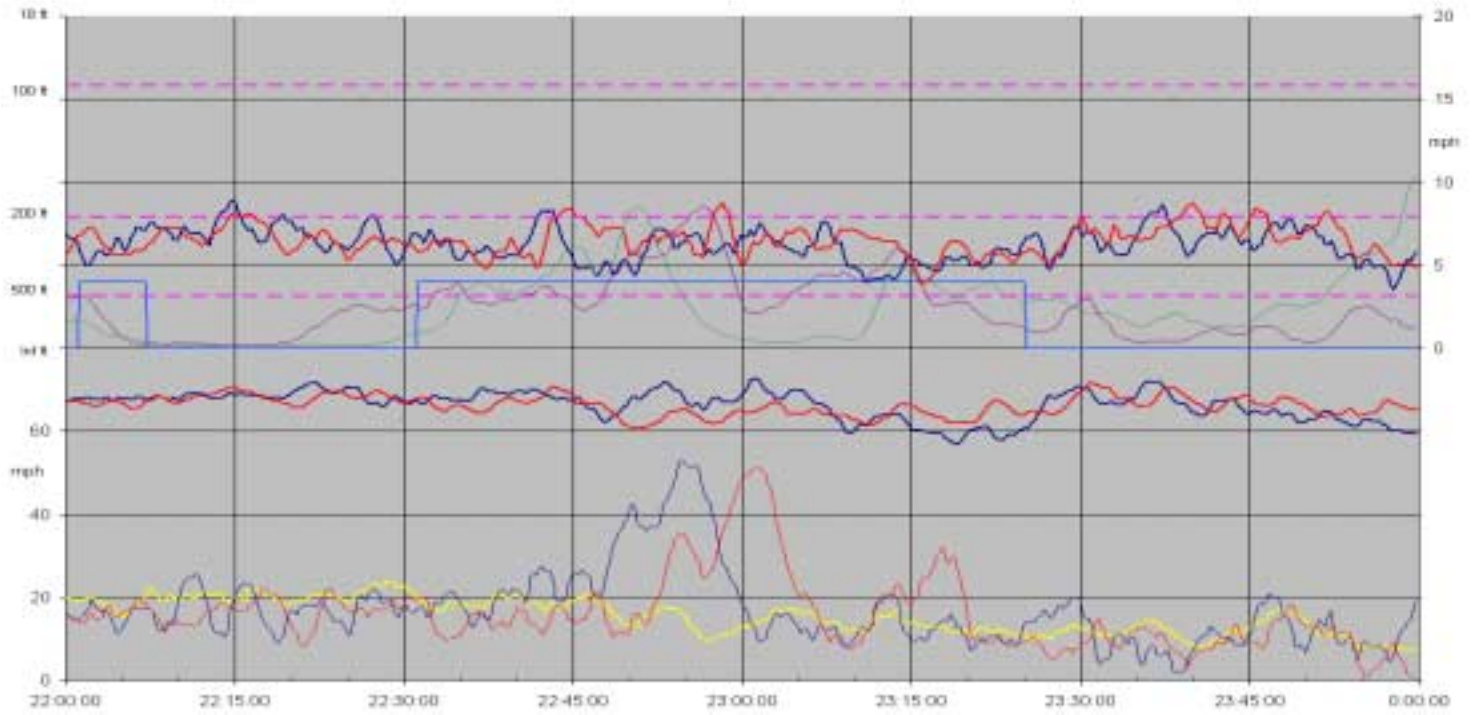

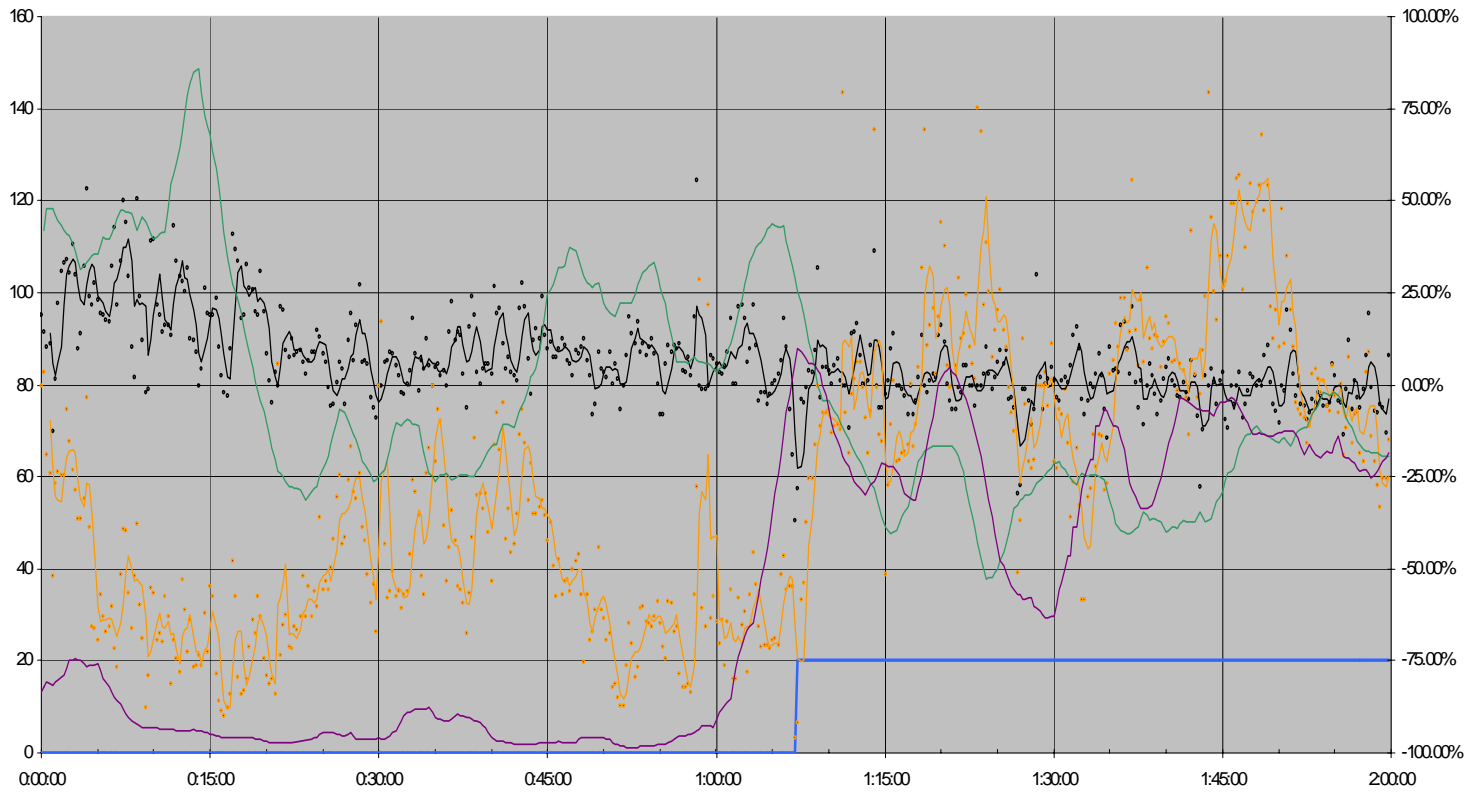

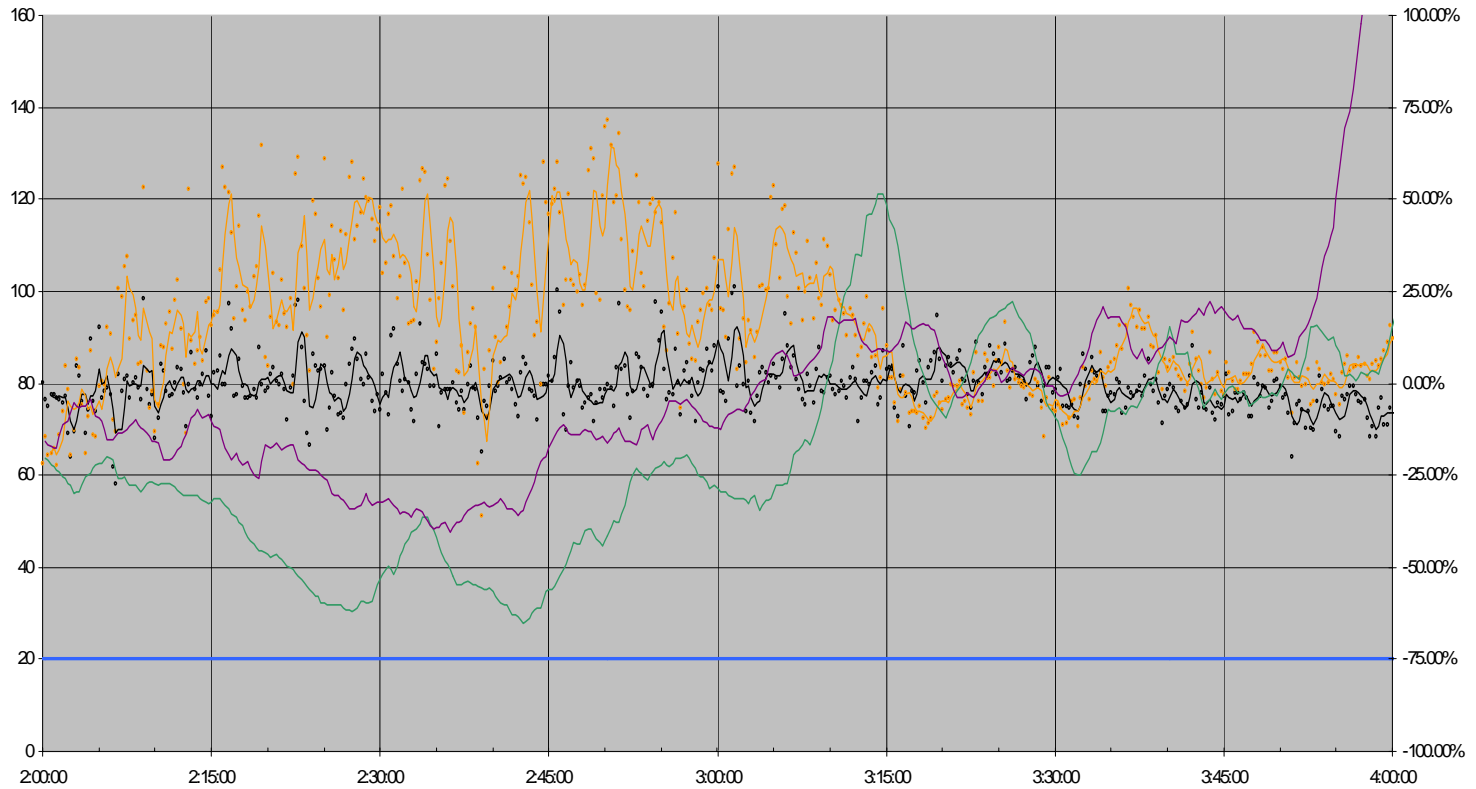

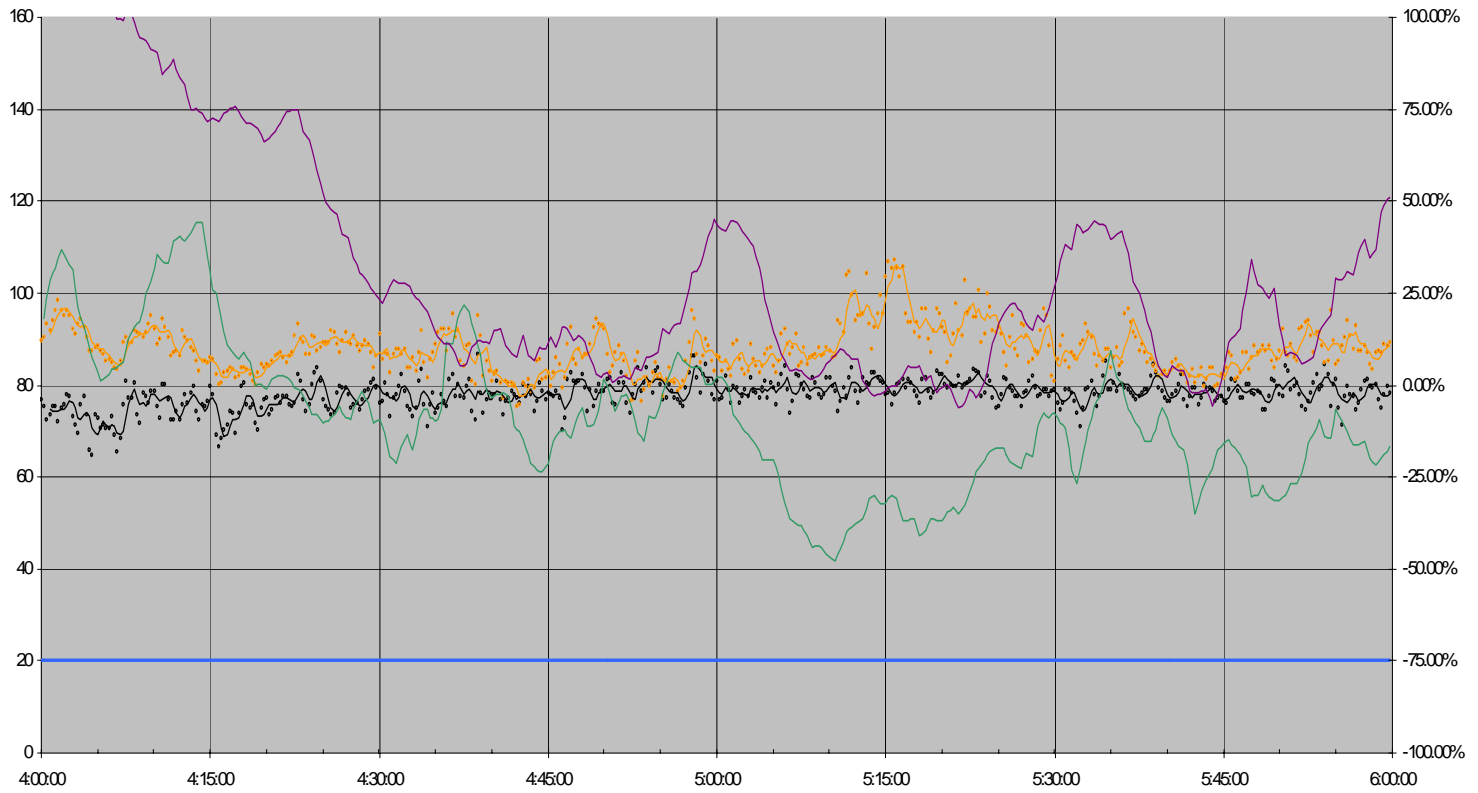
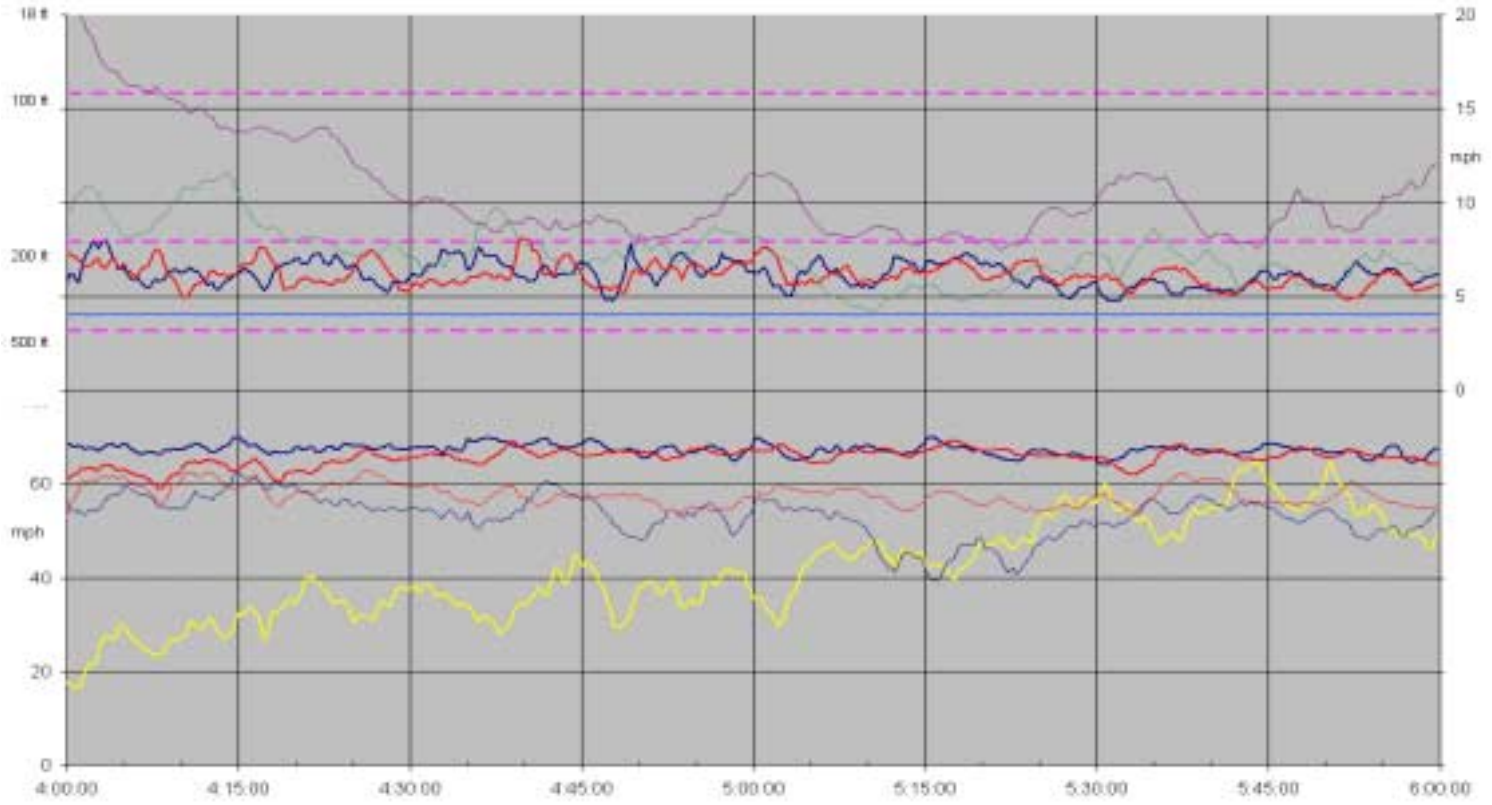

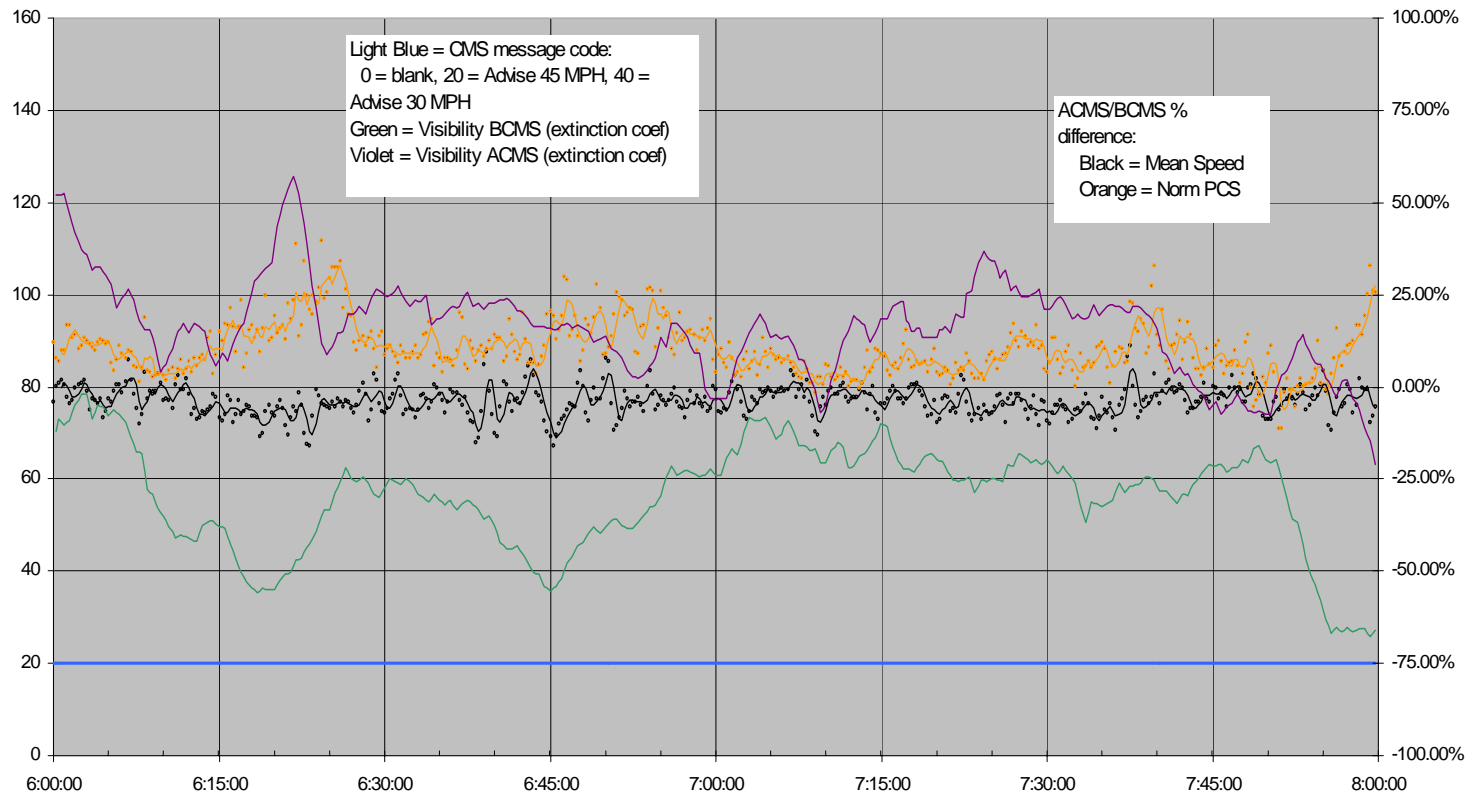
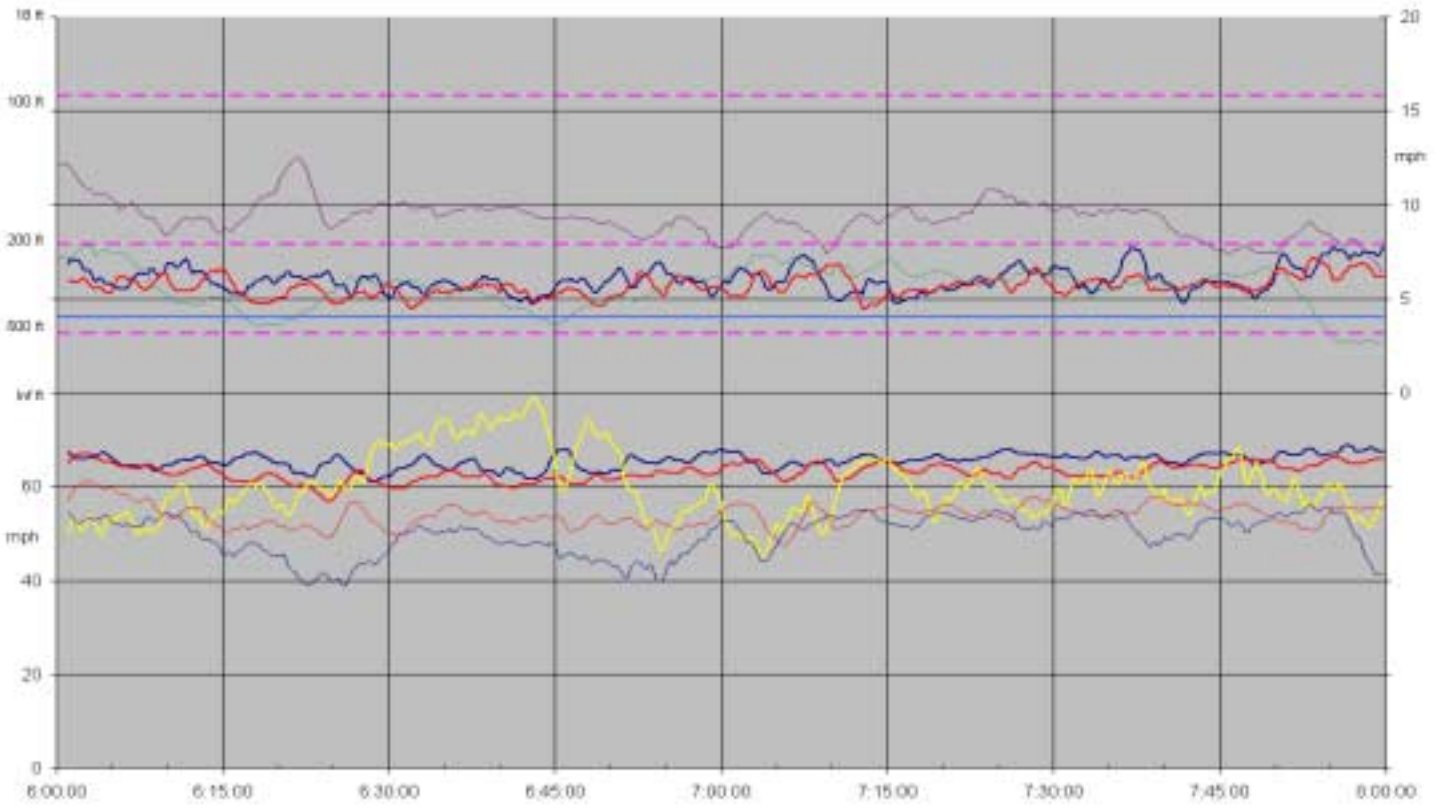

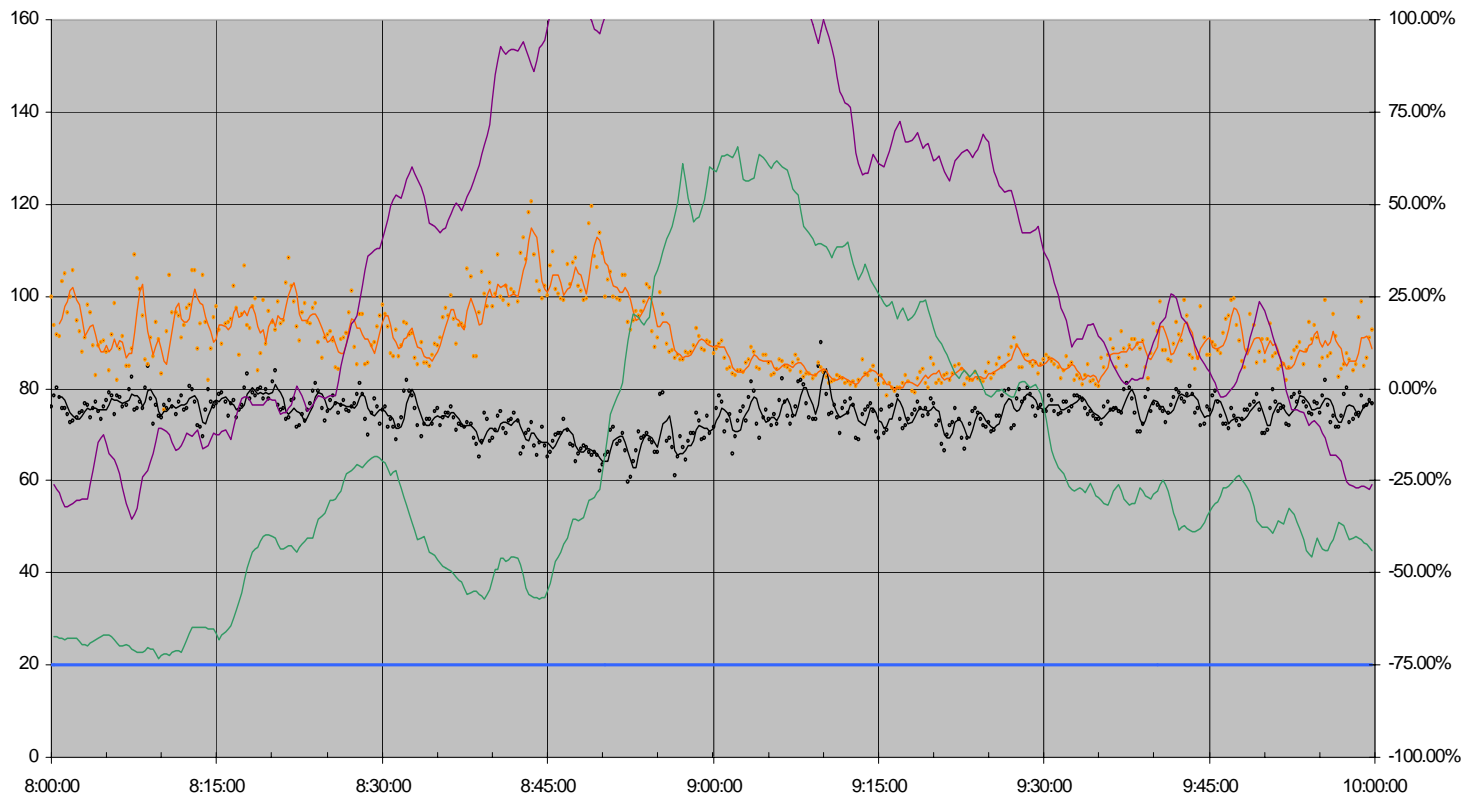
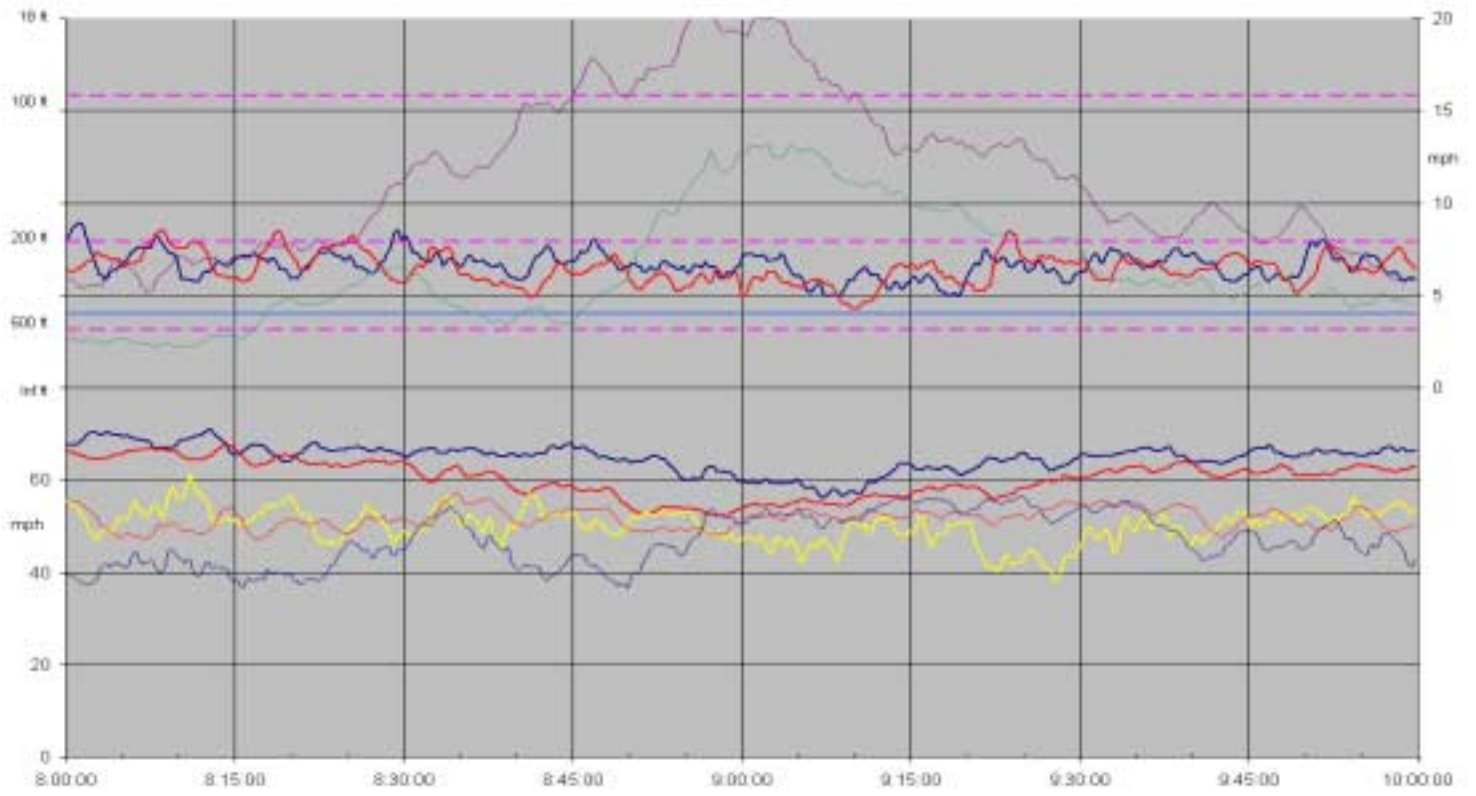

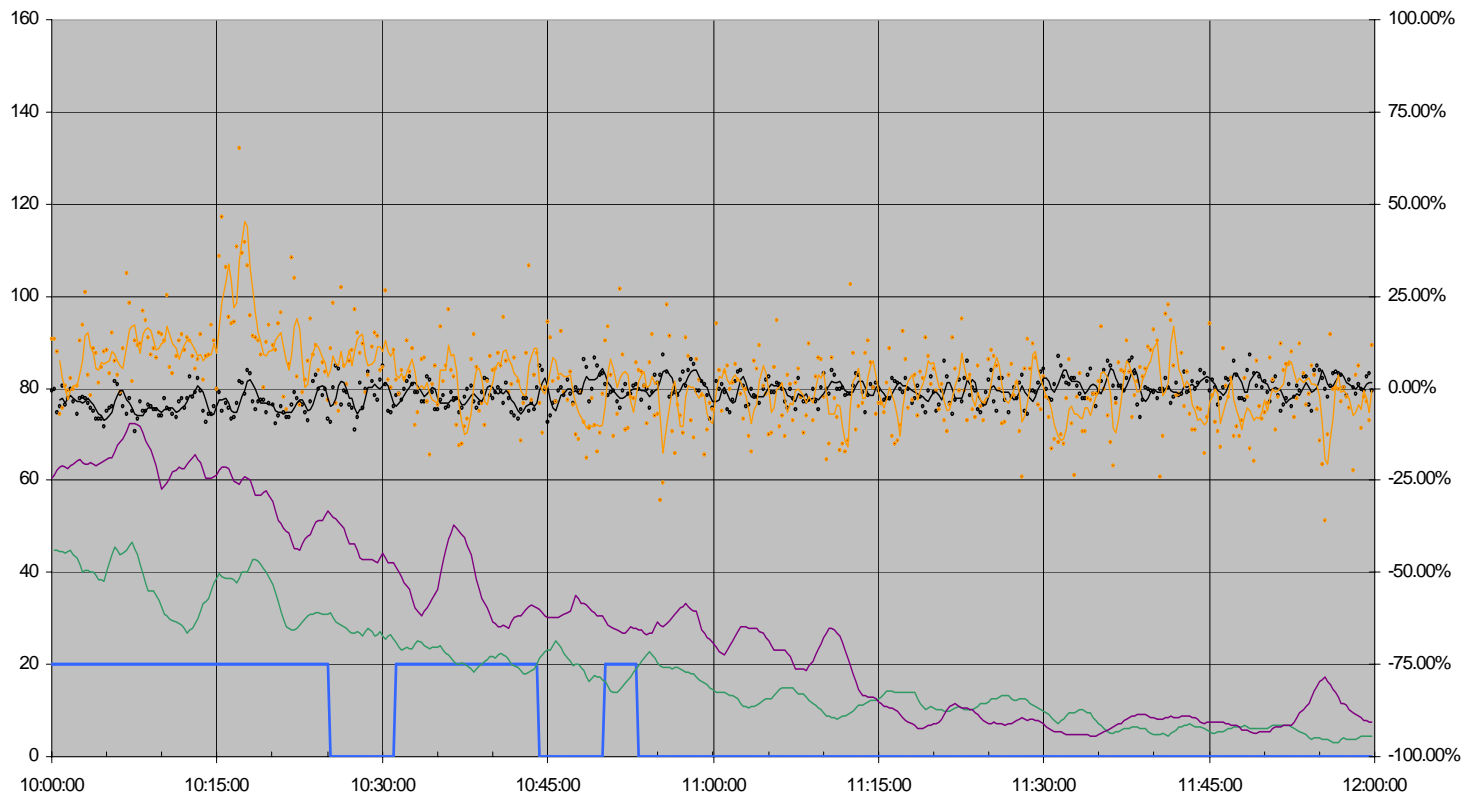
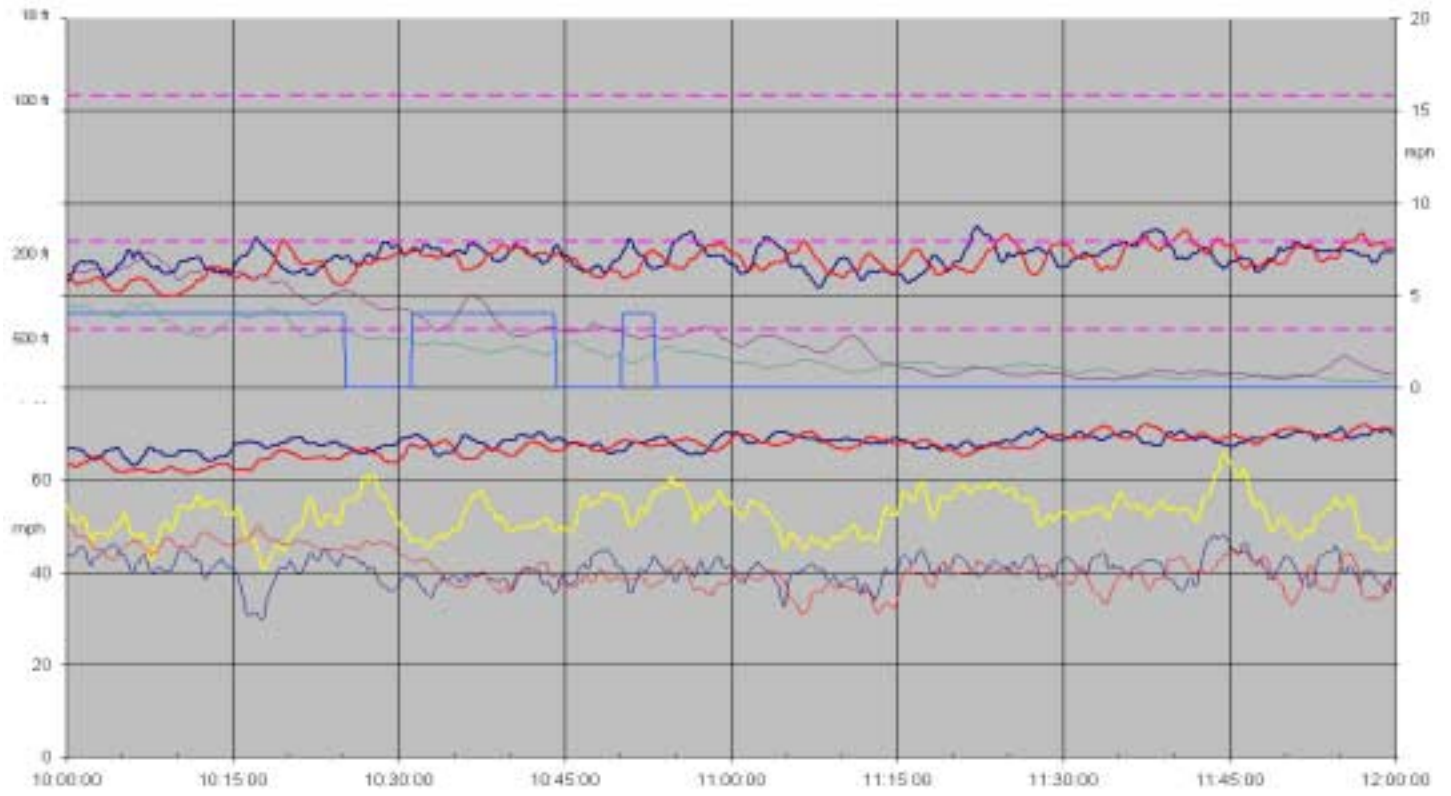

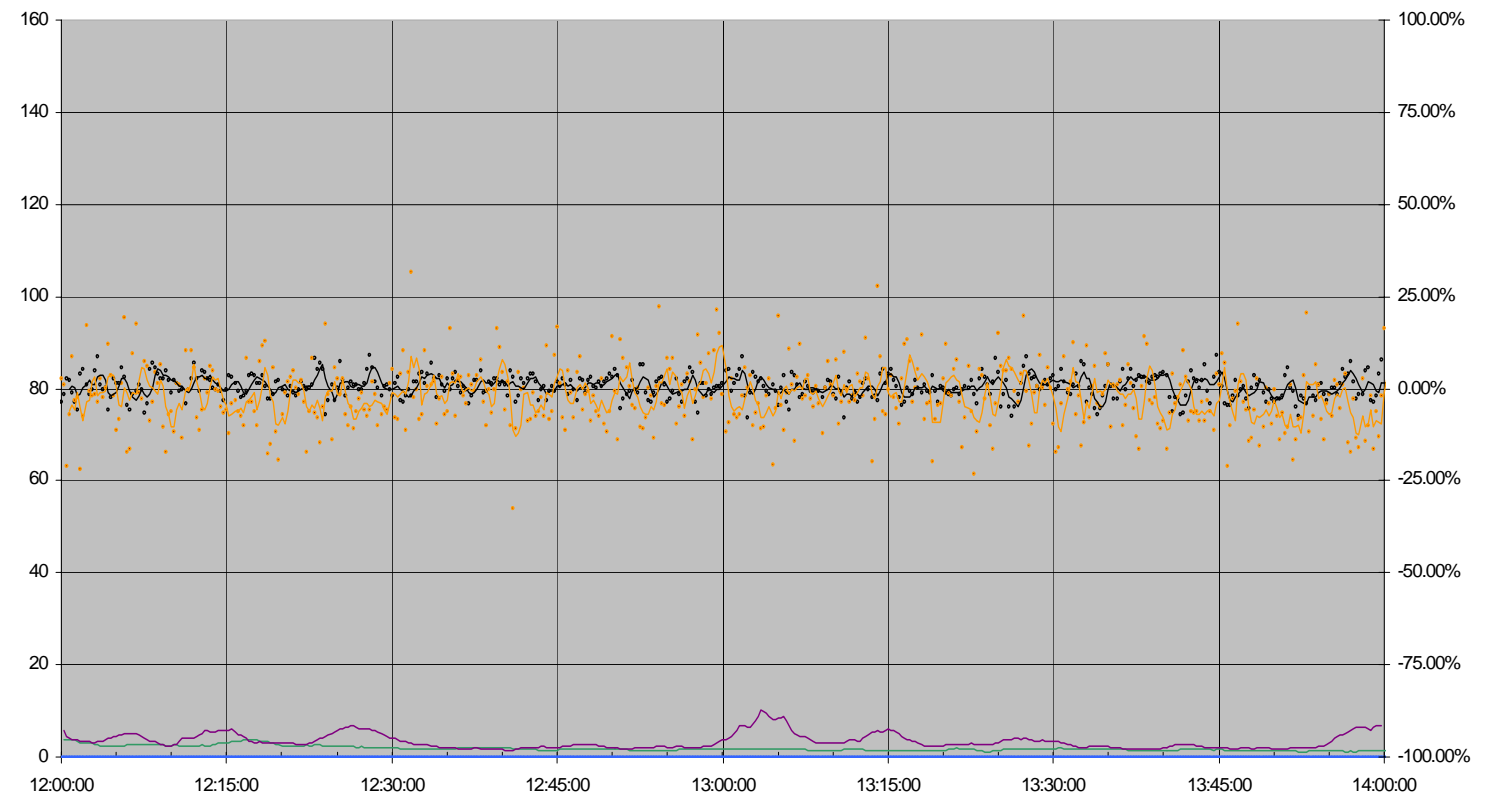
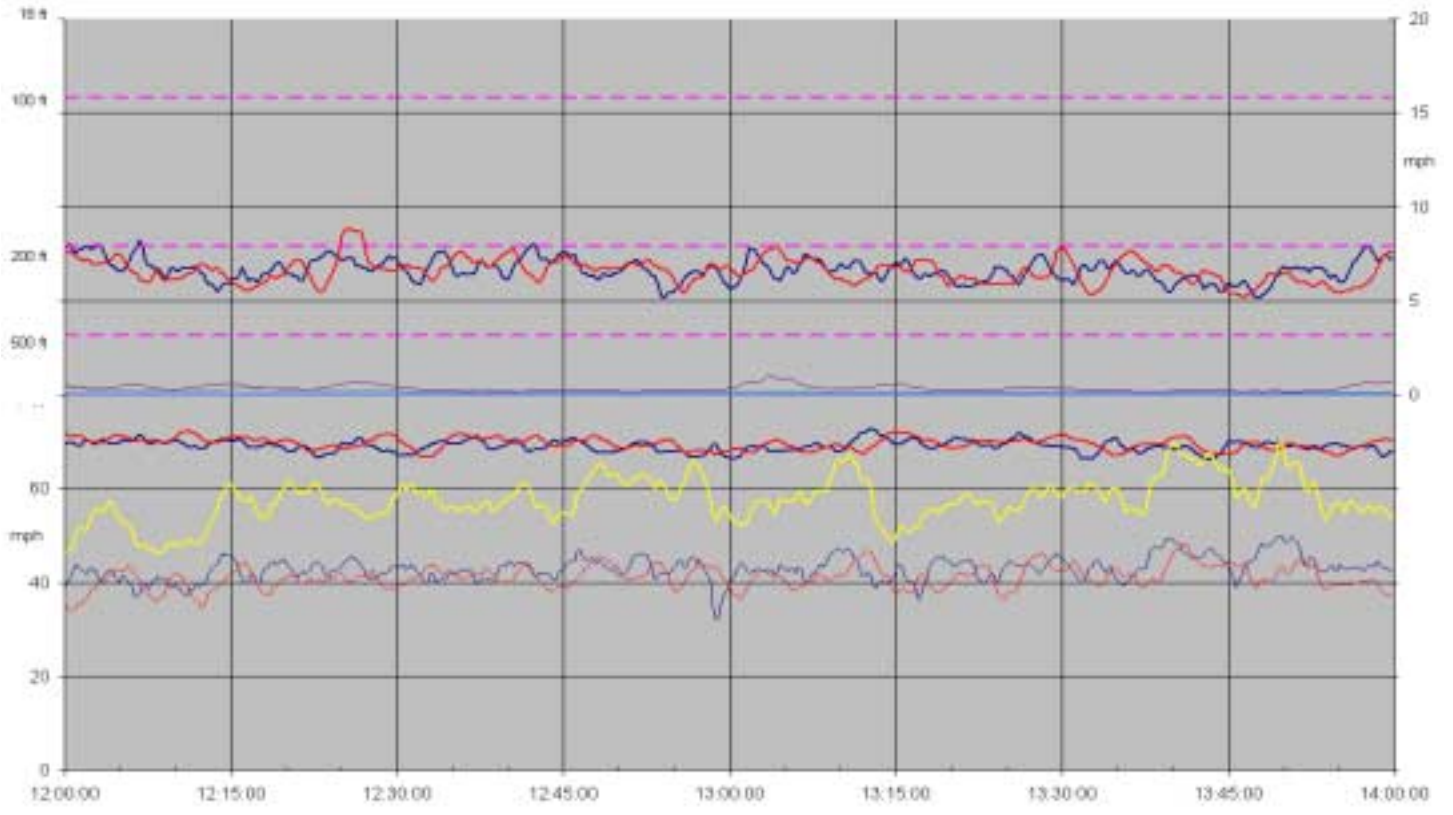



Page 1 of CMS message



Page 2 of CMS message



Sample traffic image

Figure 2.8.1.10. CMS 2-page message and sample traffic during event, from evaluation video cameras.

Table 2.8.1.9. Normalized differences, After-CMS sites VS Before-CMS sites, during constant message periods.

Start Time (mo/day/yr hr:min)	Period (sec)	CMS Messages	Speed (mph)			Stddev (mph)			Norm PCS (%)			Volume (Veh/Hr)			Vis (Extinction Coef)		
			BCMS	ACMS	%chg	BCMS	ACMS	%chg	BCMS	ACMS	%chg	BCMS	ACMS	%chg	BCMS	ACMS	%chg
12/16/2004 21:10	350	DENSE FOG/ADVISE 45 MPH	69.44	65.27	-6.01	6.95	5.95	-14.39	33.71	40.32	19.61	3117	2767	-11.22	2.68	14.22	430.6
12/16/2004 21:16	350	BLANK MESSAGE	69.49	64.84	-6.69	6.7	7.09	5.82	39.87	39.53	-0.85	3569	3394	-4.9	2.35	66.16	2715.32
12/16/2004 21:22	370	DENSE FOG/ADVISE 45 MPH	68.17	63.44	-6.94	6.96	6.13	-11.93	34.54	71.58	107.24	3240	2968	-8.41	1.66	68.32	4015.66
12/16/2004 21:40	190	BLANK MESSAGE	68.01	66.04	-2.9	7.22	6.93	-4.02	26.4	33.97	28.67	2653	2558	-3.57	9.49	36.6	285.67
12/16/2004 21:43	190	DENSE FOG/ADVISE 45 MPH	68.42	64.29	-6.04	6.7	6.38	-4.78	38.87	34.95	-10.08	3202	3013	-5.92	20.45	34.23	67.38
12/16/2004 21:55	370	BLANK MESSAGE	68.1	67.58	-0.76	7.33	6.66	-9.14	28	26.7	-4.64	2637	2374	-9.96	6.82	30.42	346.04
12/16/2004 22:01	350	DENSE FOG/ADVISE 45 MPH	67.83	66.93	-1.33	6.48	6.4	-1.23	24.94	26.62	6.74	2088	2109	0.99	10.48	7.72	-26.34
12/16/2004 22:07	350	BLANK MESSAGE	68.4	68.11	-0.42	7.57	7.24	-4.36	29.58	22.68	-23.33	2571	2469	-4	3.22	2.34	-27.33
12/16/2004 22:31	1450	DENSE FOG/ADVISE 45 MPH	68.03	65.83	-3.23	7.1	7.35	3.52	37.42	28.63	-23.49	2242	1986	-11.41	43.48	42.31	-2.69
12/16/2004 23:25	3230	BLANK MESSAGE	62.99	66.98	6.33	9.2	7.69	-16.41	32.51	15.12	-53.49	1269	1171	-7.73	59.81	10.97	-81.66
12/17/2004 1:07	3600	DENSE FOG/ADVISE 45 MPH	64.12	63.71	-0.64	7.66	7.97	4.05	55.83	54.82	-1.81	804	784	-2.49	61.48	63.98	4.07
12/17/2004 3:10	3600	DENSE FOG/ADVISE 45 MPH	66.8	64.43	-3.55	7.6	7.49	-1.45	77.87	83.46	7.18	2204	2339	6.13	86	110.4	28.35
12/17/2004 5:25	180	DENSE FOG/ADVISE 45 MPH	67.24	65.72	-2.26	6.05	6.28	3.8	71.93	83.81	16.52	6500	6340	-2.46	64.35	94.53	46.9
12/17/2004 5:28	180	DENSE FOG/ADVISE 45 MPH	65.6	64.77	-1.27	5.66	6.02	6.36	79.55	87.56	10.07	7340	6560	-10.63	71.34	109.3	53.27
12/17/2004 7:49	360	DENSE FOG/ADVISE 45 MPH	66.69	64.79	-2.85	6.9	6.94	0.58	82.12	81.08	-1.27	8020	6340	-20.95	55.5	84.16	51.64
12/17/2004 7:55	360	DENSE FOG/ADVISE 45 MPH	67.39	65.25	-3.18	7.94	6.74	-15.11	72.89	83.89	15.09	7380	6070	-17.75	27.74	66.62	140.16
12/17/2004 8:01	360	DENSE FOG/ADVISE 45 MPH	69.5	66.01	-5.02	7.77	7.56	-2.7	59.99	73.3	22.19	6450	5480	-15.04	25.46	60.52	137.71
12/17/2004 8:28	1620	DENSE FOG/ADVISE 45 MPH	65.68	58.19	-11.4	7.37	7.2	-2.31	68.98	89.26	29.4	6460	5836	-9.67	53.51	149.9	180.06
12/17/2004 9:58	1610	DENSE FOG/ADVISE 45 MPH	66.54	63.53	-4.52	7.13	6.45	-9.54	64.44	73.62	14.25	6256	5782	-7.58	37.9	59.97	58.23
12/17/2004 10:25	370	BLANK MESSAGE	66.86	65.54	-1.97	7.68	7.66	-0.26	63.31	69.78	10.22	6947	6324	-8.96	27.88	42.73	53.26
12/17/2004 10:31	370	DENSE FOG/ADVISE 45 MPH	67.99	66.39	-2.35	7.95	7.14	-10.19	59.37	61.22	3.12	6315	5906	-6.47	23.83	40.4	69.53
12/17/2004 10:44	370	BLANK MESSAGE	67.8	67.78	-0.03	7.31	6.41	-12.31	63.34	60.44	-4.58	6616	6120	-7.5	20.77	30.87	48.63
12/17/2004 10:50	170	DENSE FOG/ADVISE 45 MPH	66.98	67.2	0.33	7.8	7.26	-6.92	61.57	58.27	-5.36	6692	6247	-6.65	15.53	27.32	75.92
12/17/2004 10:53	170	BLANK MESSAGE	69.22	68.81	-0.59	6.76	6.53	-3.4	62.08	62.67	0.95	7264	6713	-7.58	20.7	29.47	42.37

Table 2.8.1.10. Normalized change in metrics measured during period 15 minutes after vs period 15 minutes before each message transition.

CMS TRANSITION			Speed (mph)			Stddev (mph)			Norm PCS (%)			Volume (Veh/Hr)			Vis (Extinction Coef)		
Time of Transition	CMS Message		BCMS	ACMS	%chg	BCMS	ACMS	%chg	BCMS	ACMS	%chg	BCMS	ACMS	%chg	BCMS	ACMS	%chg
12/16/2004 21:10	PRE	BLANK MESSAGE	70.49	66.58	-5.55	7.44	6.76	-9.14	31.99	35.8	11.91	2940	2616	-11.02	2.49	35.57	1328.51
	POST	DENSE FOG/ADVISE 45 MPH	69.36	65.48	-5.59	6.79	5.8	-14.58	35.62	41.88	17.57	3408	2904	-14.79	2.75	11.54	319.64
	Period Size: 300s			-1.6	-1.65	-0.05	-8.74	-14.2	-5.99	11.35	16.98	5.06	15.92	11.01	-4.24	10.44	-67.56
12/16/2004 21:16	PRE	DENSE FOG/ADVISE 45 MPH	69.26	65.13	-5.96	6.86	5.94	-13.41	32.61	38.54	18.18	2988	2832	-5.22	2.66	15	463.91
	POST	BLANK MESSAGE	69.84	64.6	-7.5	6.32	6.51	3.01	40.84	37.53	-8.1	3576	3324	-7.05	2.41	64.93	2594.19
	Period Size: 300s			0.84	-0.81	-1.64	-7.87	9.6	18.96	25.24	-2.62	-22.24	19.68	17.37	-1.93	-9.4	332.87
12/16/2004 21:22	PRE	BLANK MESSAGE	69.61	64.88	-6.8	6.84	7.34	7.31	42.89	42.34	-1.28	3864	3588	-7.14	2.27	72.03	3073.13
	POST	DENSE FOG/ADVISE 45 MPH	68.55	63.68	-7.1	7.11	6.02	-15.33	34.27	71.93	109.89	3360	3084	-8.21	1.66	69.57	4090.96
	Period Size: 300s			-1.52	-1.85	-0.33	3.95	-17.98	-21.1	-20.1	69.89	112.62	-13.04	-14.05	-1.15	-26.87	-3.42
12/16/2004 21:40	PRE	DENSE FOG/ADVISE 45 MPH	68.14	67.54	-0.88	6.95	6.59	-5.18	37.85	38.93	2.85	3221	3221	0	5.77	28.49	393.76
	POST	BLANK MESSAGE	68.01	66.04	-2.9	7.22	6.93	-4.02	26.4	33.97	28.67	2653	2558	-3.57	9.49	36.6	285.67
	Period Size: 190s			-0.19	-2.22	-2.03	3.88	5.16	1.23	-30.25	-12.74	25.1	-17.65	-20.59	-3.57	64.47	28.47
12/16/2004 21:43	PRE	BLANK MESSAGE	68.01	66.04	-2.9	7.22	6.93	-4.02	26.4	33.97	28.67	2653	2558	-3.57	9.49	36.6	285.67
	POST	DENSE FOG/ADVISE 45 MPH	68.42	64.29	-6.04	6.7	6.38	-4.78	38.87	34.95	-10.08	3202	3013	-5.92	20.45	34.23	67.38
	Period Size: 190s			0.6	-2.65	-3.23	-7.2	-7.94	-0.79	47.23	2.88	-30.12	20.71	17.78	-2.43	115.49	-6.48
12/16/2004 21:55	PRE	DENSE FOG/ADVISE 45 MPH	67.94	66.51	-2.1	7.23	6.9	-4.56	27.9	26.97	-3.33	2352	2112	-10.2	1.93	19.23	896.37
	POST	BLANK MESSAGE	68.36	67.79	-0.83	7.12	6.37	-10.53	29.92	27.55	-7.92	2556	2400	-6.1	5.37	30.84	474.3
	Period Size: 300s			0.62	1.92	1.3	-1.52	-7.68	-6.25	7.24	2.15	-4.75	8.67	13.64	4.57	178.24	60.37
12/16/2004 22:01	PRE	BLANK MESSAGE	67.4	67.11	-0.43	7.22	6.59	-8.73	28.45	23.1	-18.8	2604	2184	-16.13	7.72	30.87	299.87
	POST	DENSE FOG/ADVISE 45 MPH	67.54	66.49	-1.55	6.28	6.21	-1.11	25.21	29.16	15.67	2220	2136	-3.78	11.55	8.25	-28.57
	Period Size: 300s			0.21	-0.92	-1.13	-13.02	-5.77	8.34	-11.39	26.23	42.46	-14.75	-2.2	14.72	49.61	-73.28
12/16/2004 22:07	PRE	DENSE FOG/ADVISE 45 MPH	68.02	67.07	-1.4	6.72	6.29	-6.4	24.85	25.78	3.74	2004	2004	0	9.19	6.4	-30.36
	POST	BLANK MESSAGE	67.72	67.78	0.09	7.29	7.07	-3.02	27.72	22.07	-20.38	2544	2472	-2.83	3.23	2.34	-27.55
	Period Size: 300s			-0.44	1.06	1.51	8.48	12.4	3.61	11.55	-14.39	-23.25	26.95	23.35	-2.83	-64.85	-63.44
12/16/2004 22:31	PRE	BLANK MESSAGE	67.81	68.07	0.38	7.51	6.51	-13.32	28.76	27.89	-3.03	2832	2556	-9.75	3.8	24.73	550.79
	POST	DENSE FOG/ADVISE 45 MPH	66.85	65.06	-2.68	7.12	6.37	-10.53	28.86	22.52	-21.97	2316	2052	-11.4	16.65	32.52	95.32
	Period Size: 300s			-1.42	-4.42	-3.05	-5.19	-2.15	3.21	0.35	-19.25	-19.53	-18.22	-19.72	-1.83	338.16	31.5
12/16/2004 23:25	PRE	DENSE FOG/ADVISE 45 MPH	59.43	65.86	10.82	7.31	6.24	-14.64	16.07	16.57	3.11	1440	1284	-10.83	35.09	13.9	-60.39
	POST	BLANK MESSAGE	65.14	67.07	2.96	7.85	7.48	-4.71	25.2	15.87	-37.02	1404	1344	-4.27	28.43	20.09	-29.34
	Period Size: 300s			9.61	1.84	-7.09	7.39	19.87	11.63	56.81	-4.22	-38.92	-2.5	4.67	7.36	-18.98	44.53
12/17/2004	PRE	BLANK MESSAGE	60.67	64.46	6.25	6.08	7.91	30.1	73.43	12.21	-83.37	816	708	-13.24	109	65.82	-39.61

1:07	POST	DENSE FOG/ADVISE 45 MPH	65.06	66.4	2.06	8.98	10.17	13.25	85.29	61.06	-28.41	672	648	-3.57	82.85	68.25	-17.62
	Period Size: 300s		7.24	3.01	-3.94	47.7	28.57	-12.95	16.15	400.08	330.54	-17.65	-8.47	11.14	-23.99	3.69	36.42
12/17/2004 3:10	PRE	DENSE FOG/ADVISE 45 MPH	60.39	61.91	2.52	7.21	6.52	-9.57	43.18	72.16	67.11	1404	1272	-9.4	63.87	88.04	37.84
	POST	DENSE FOG/ADVISE 45 MPH	63.07	62.36	-1.13	6.11	6.52	6.71	58.12	75.65	30.16	1512	1608	6.35	102.95	89.08	-13.47
	Period Size: 300s		4.44	0.73	-3.55	-15.26	0	18	34.6	4.84	-22.11	7.69	26.42	17.39	61.19	1.18	-37.23
12/17/2004 5:25	PRE	DENSE FOG/ADVISE 45 MPH	65.05	65.81	1.17	6.17	6.63	7.46	65	82.72	27.26	5780	5960	3.11	60.88	92.65	52.18
	POST	DENSE FOG/ADVISE 45 MPH	67.24	65.72	-2.26	6.05	6.28	3.8	71.93	83.81	16.52	6500	6340	-2.46	64.35	94.53	46.9
	Period Size: 180s		3.37	-0.14	-3.39	-1.94	-5.28	-3.4	10.66	1.32	-8.44	12.46	6.38	-5.41	5.7	2.03	-3.47
12/17/2004 5:28	PRE	DENSE FOG/ADVISE 45 MPH	67.24	65.72	-2.26	6.05	6.28	3.8	71.93	83.81	16.52	6500	6340	-2.46	64.35	94.53	46.9
	POST	DENSE FOG/ADVISE 45 MPH	65.6	64.77	-1.27	5.66	6.02	6.36	79.55	87.56	10.07	7340	6560	-10.63	71.34	109.34	53.27
	Period Size: 180s		-2.44	-1.45	1.02	-6.45	-4.14	2.47	10.59	4.47	-5.53	12.92	3.47	-8.37	10.86	15.67	4.33
12/17/2004 7:49	PRE	DENSE FOG/ADVISE 45 MPH	66.74	65.54	-1.8	5.83	5.67	-2.74	78.66	84.41	7.31	8256	6828	-17.3	62.55	75.36	20.48
	POST	DENSE FOG/ADVISE 45 MPH	66.27	64.38	-2.85	6.86	7	2.04	82.01	80.27	-2.12	8136	6336	-22.12	58.93	85.22	44.61
	Period Size: 300s		-0.7	-1.77	-1.07	17.67	23.46	4.92	4.26	-4.9	-8.79	-1.45	-7.21	-5.84	-5.79	13.08	20.03
12/17/2004 7:55	PRE	DENSE FOG/ADVISE 45 MPH	67.78	65.12	-3.92	7.05	6.71	-4.82	81.34	81.06	-0.34	7404	6096	-17.67	53.23	84.79	59.29
	POST	DENSE FOG/ADVISE 45 MPH	67.63	65.56	-3.06	8.11	6.7	-17.39	74.79	84.13	12.49	7260	6024	-17.02	27.96	68.91	146.46
	Period Size: 300s		-0.22	0.68	0.9	15.04	-0.15	-13.2	-8.05	3.79	12.88	-1.94	-1.18	0.78	-47.47	-18.73	54.72
12/17/2004 8:01	PRE	DENSE FOG/ADVISE 45 MPH	68.27	65.49	-4.07	7.6	6.79	-10.66	69.87	83.6	19.65	7092	5976	-15.74	26.98	63.64	135.88
	POST	DENSE FOG/ADVISE 45 MPH	69.54	65.88	-5.26	7.77	7.26	-6.56	60.46	73.88	22.2	6624	5496	-17.03	25.59	61.14	138.92
	Period Size: 300s		1.86	0.6	-1.24	2.24	6.92	4.58	-13.47	-11.63	2.13	-6.6	-8.03	-1.53	-5.15	-3.93	1.29
12/17/2004 8:28	PRE	DENSE FOG/ADVISE 45 MPH	66.91	63.93	-4.45	7.07	7.3	3.25	66.34	79.73	20.18	6156	5616	-8.77	53.91	92.02	70.69
	POST	DENSE FOG/ADVISE 45 MPH	66.13	61.89	-6.41	7.87	7.49	-4.83	70.98	83.71	17.93	6228	5688	-8.67	62.06	120.45	94.09
	Period Size: 300s		-1.17	-3.19	-2.05	11.32	2.6	-7.83	6.99	4.99	-1.87	1.17	1.28	0.11	15.12	30.9	13.71
12/17/2004 9:58	PRE	DENSE FOG/ADVISE 45 MPH	65.56	62.7	-4.36	7.04	7.05	0.14	72.04	81.31	12.87	6780	6168	-9.03	47.61	62.98	32.28
	POST	DENSE FOG/ADVISE 45 MPH	66.71	63.75	-4.44	6.67	6.05	-9.3	68.09	74.36	9.21	6360	6060	-4.72	45.47	63.08	38.73
	Period Size: 300s		1.75	1.67	-0.08	-5.26	-14.18	-9.42	-5.48	-8.55	-3.24	-6.19	-1.75	4.74	-4.49	0.16	4.87
12/17/2004 10:25	PRE	DENSE FOG/ADVISE 45 MPH	68.31	65.21	-4.54	6.63	6.54	-1.36	62.62	69.9	11.63	6240	5820	-6.73	31.17	49.32	58.23
	POST	BLANK MESSAGE	66.63	65.22	-2.12	7.59	7.51	-1.05	64.95	70.99	9.3	7320	6612	-9.67	28.19	44.11	56.47
	Period Size: 300s		-2.46	0.02	2.54	14.48	14.83	0.31	3.72	1.56	-2.08	17.31	13.61	-3.15	-9.56	-10.56	-1.11
12/17/2004 10:31	PRE	BLANK MESSAGE	66.43	65.61	-1.23	7.61	7.81	2.63	61.75	68.9	11.58	6792	6144	-9.54	27.25	41.36	51.78
	POST	DENSE FOG/ADVISE 45 MPH	67.75	66.24	-2.23	8.06	7.08	-12.16	59.44	60.6	1.95	6312	5760	-8.75	24.2	40.24	66.28
	Period Size: 300s		1.99	0.96	-1.01	5.91	-9.35	-14.41	-3.74	-12.05	-8.63	-7.07	-6.25	0.88	-11.19	-2.71	9.55
12/17/2004 10:44	PRE	DENSE FOG/ADVISE 45 MPH	69.08	66.96	-3.07	7.42	7.41	-0.13	59.05	61.18	3.61	6252	5784	-7.49	20.38	30.42	49.26
	POST	BLANK MESSAGE	68.19	67.38	-1.19	7.24	6.55	-9.53	60.77	60.24	-0.87	6420	6156	-4.11	21.52	31.76	47.58
	Period Size: 300s		-1.29	0.63	1.94	-2.43	-11.61	-9.41	2.91	-1.54	-4.32	2.69	6.43	3.65	5.59	4.4	-1.13
12/17/2004	PRE	BLANK MESSAGE	67.15	68.29	1.7	7.02	6.34	-9.69	68.6	60.33	-12.06	7264	6311	-13.12	19	29.45	55

Evaluation of Caltrans Automated Warning System

Analysis of Driver Response

10:50	POST	DENSE FOG/ADVISE 45 MPH	66.98	67.2	0.33	7.8	7.26	-6.92	61.57	58.27	-5.36	6692	6247	-6.65	15.53	27.32	75.92
	Period Size: 170s		-0.25	-1.6	-1.35	11.11	14.51	3.06	-10.25	-3.41	7.61	-7.87	-1.01	7.45	-18.26	-7.23	13.5
12/17/2004 10:53	PRE	DENSE FOG/ADVISE 45 MPH	66.98	67.2	0.33	7.8	7.26	-6.92	61.57	58.27	-5.36	6692	6247	-6.65	15.53	27.32	75.92
	POST	BLANK MESSAGE	69.22	68.81	-0.59	6.76	6.53	-3.4	62.08	62.67	0.95	7264	6713	-7.58	20.7	29.47	42.37
	Period Size: 170s		3.34	2.4	-0.92	-13.33	-10.06	3.78	0.83	7.55	6.67	8.54	7.46	-1	33.29	7.87	-19.07

2.8.1.6 December 19-20, 2004, Time: 8pm-6am

Synopsis:

Light foggy night with multiple CMS changes, light volume.

Data collection system status:**Files:**

2004-12-19-fog-event.xls, 2004-12-19-constant-message-intervals.xls, 2004-12-19-message-transitions.xls

Narrative:

This event is useful because it contains a period of several hours in which the visibility BCMS and ACMS were approximately equal. Since it is known that drivers primarily respond to the visibility, this allows us to better isolate the possible affect of the CMS on driver behavior.

In the period between 10:00 PM and 2:00 AM, a consistent drop in mean speed, averaging approximately 2-3 mph was observed at the ACMS sites compared with the BCMS. The CMS message was displayed most of this period. However, PCS was slightly higher ACMS than BCMS during this period. Since visibility was only slightly worse ACMS than BCMS, this may be an indication of a combined effect of both drivers' perception of visibility and the CMS message. Drivers did reduce speed slightly, although when following distance and visibility were factored in (as indicated by PCS), they were actually driving slightly less safely.

Figure 2.8.1.11. Time history of event in two-hour increments (series of plots below).

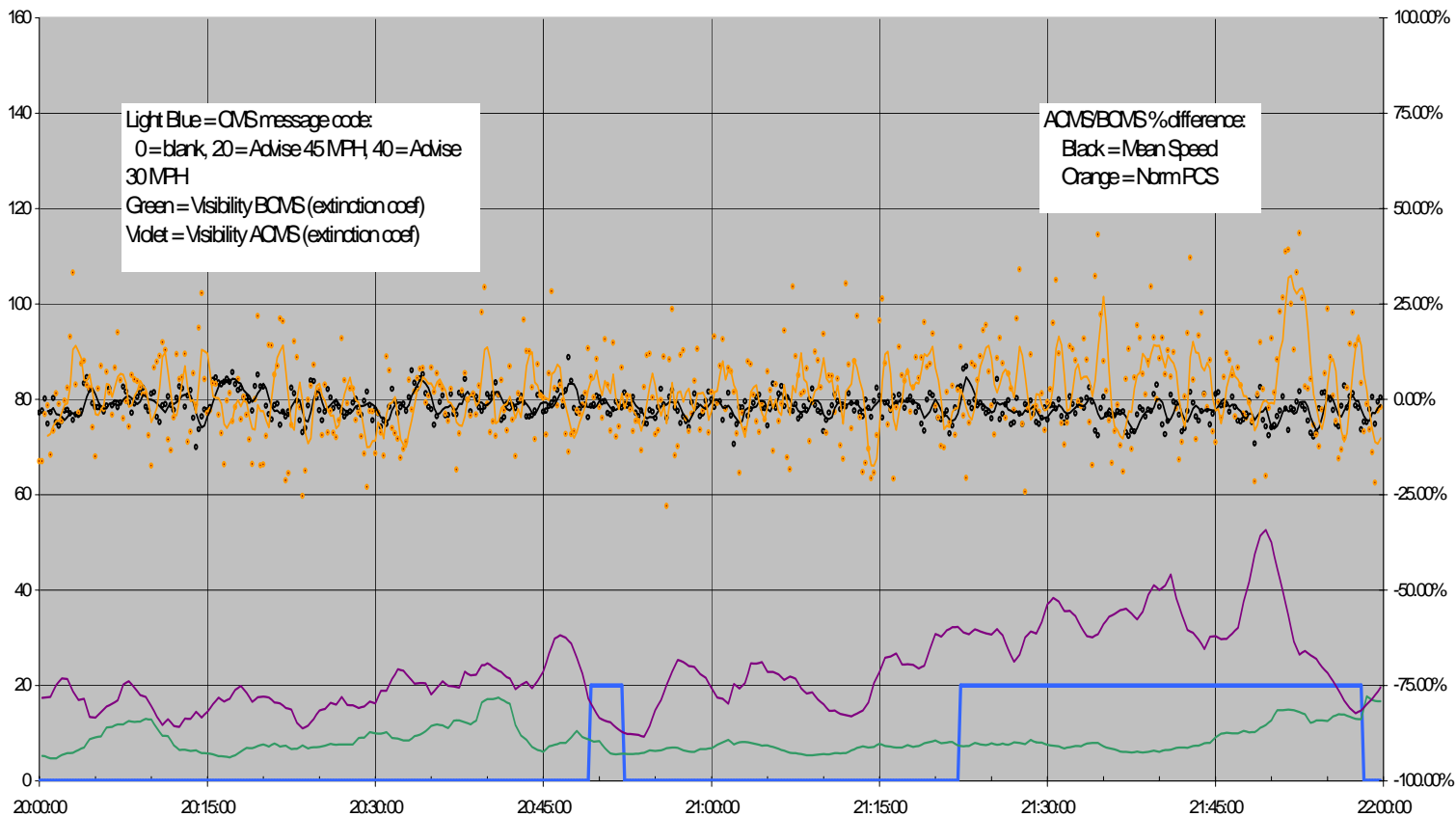
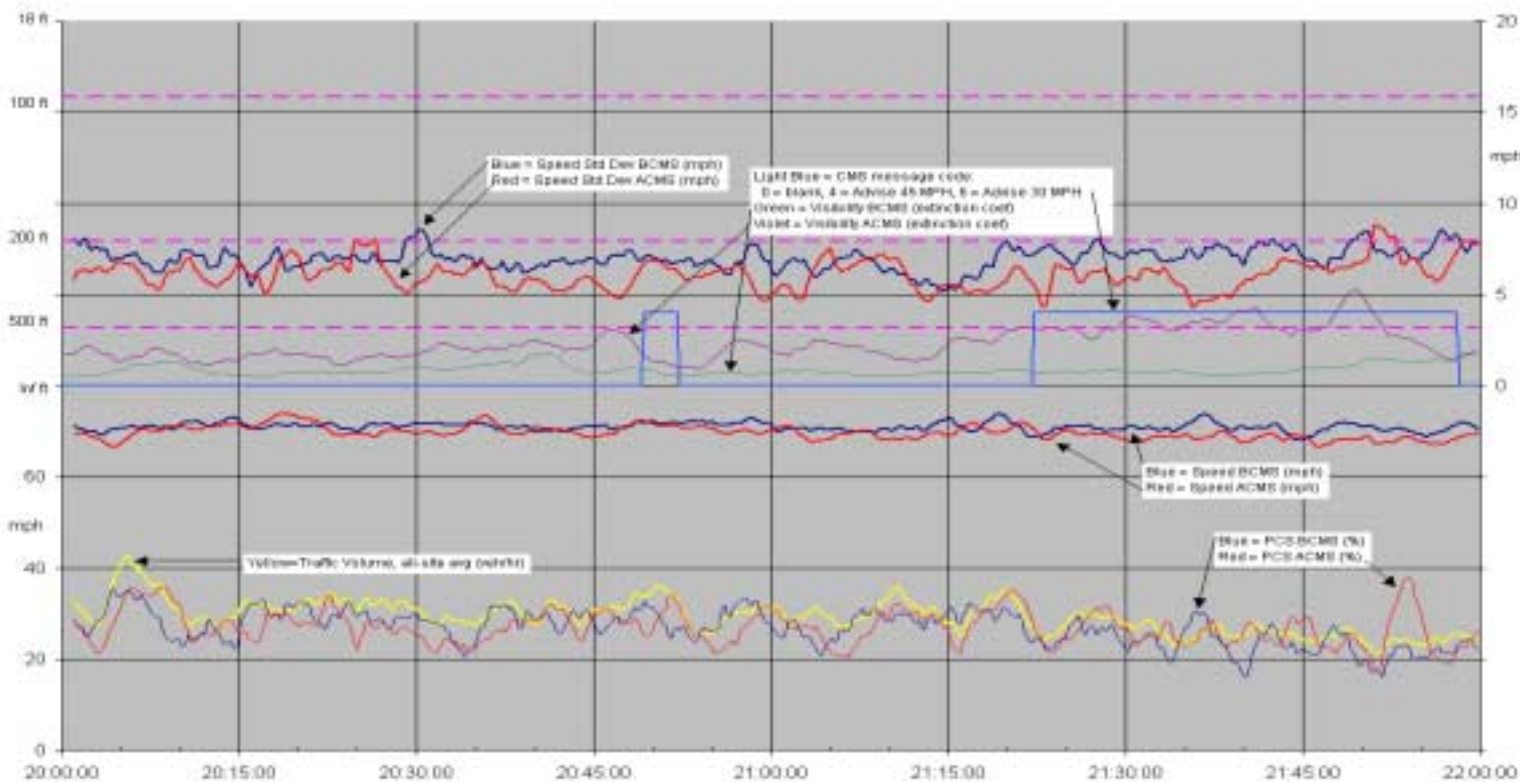

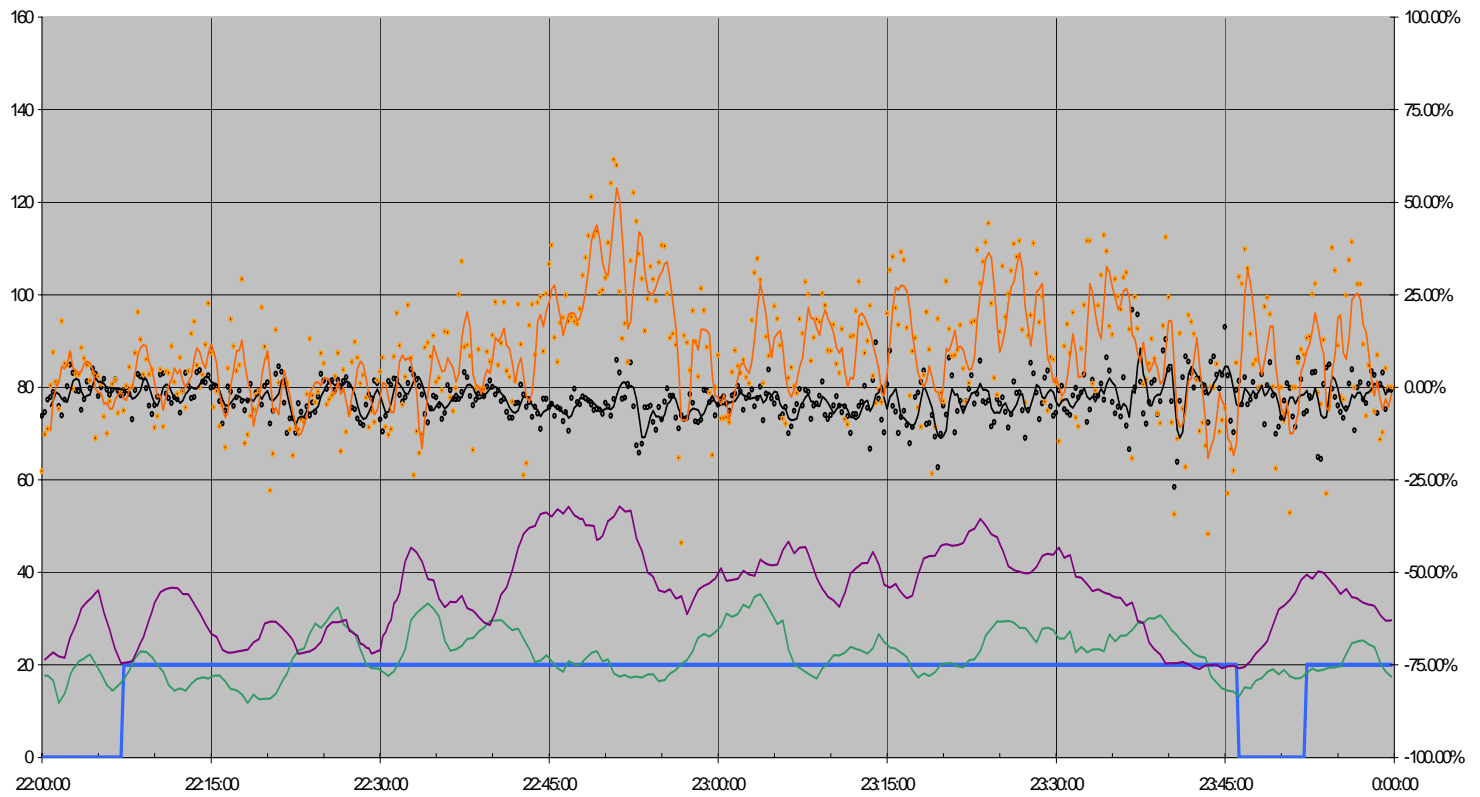
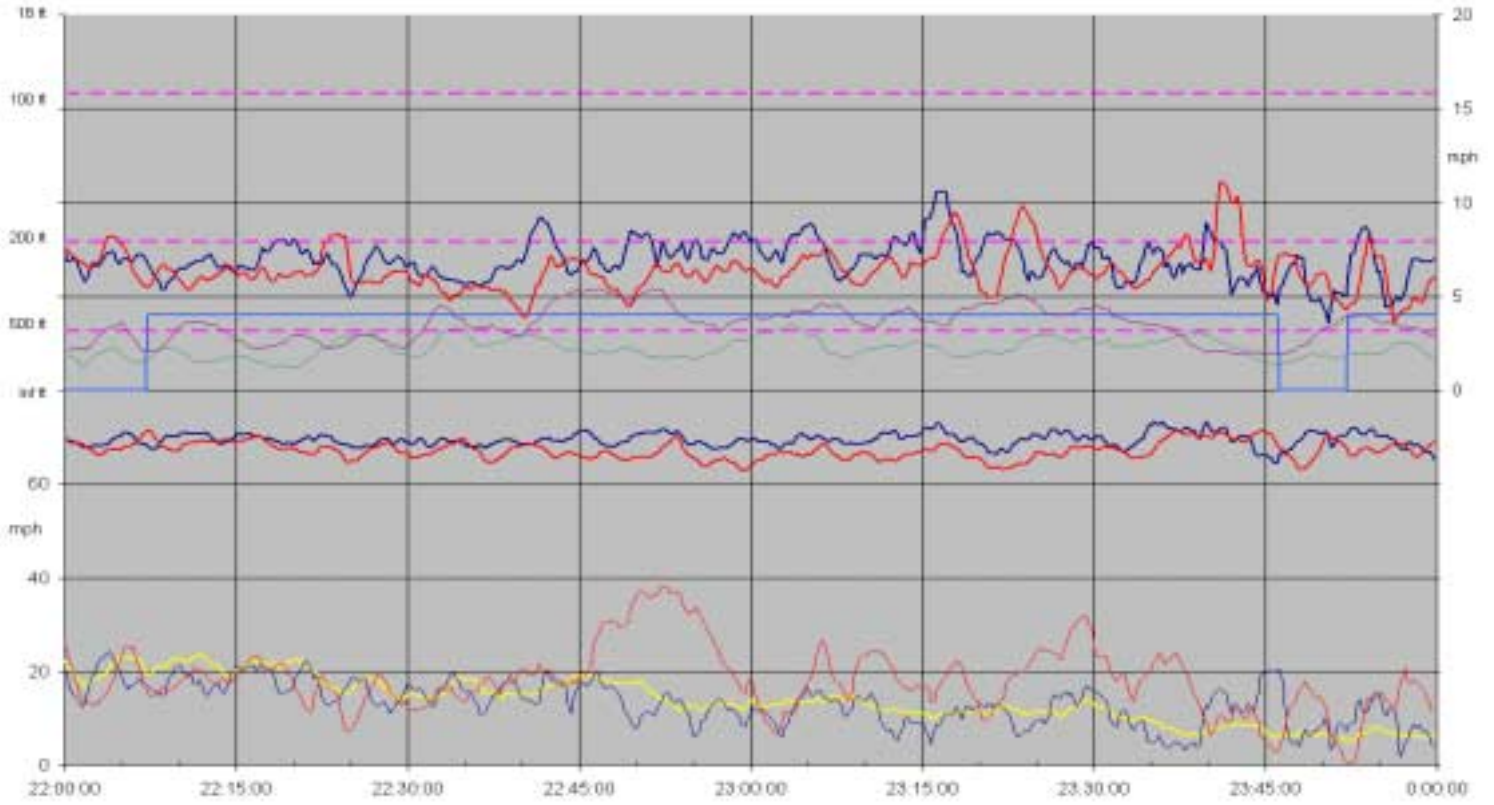

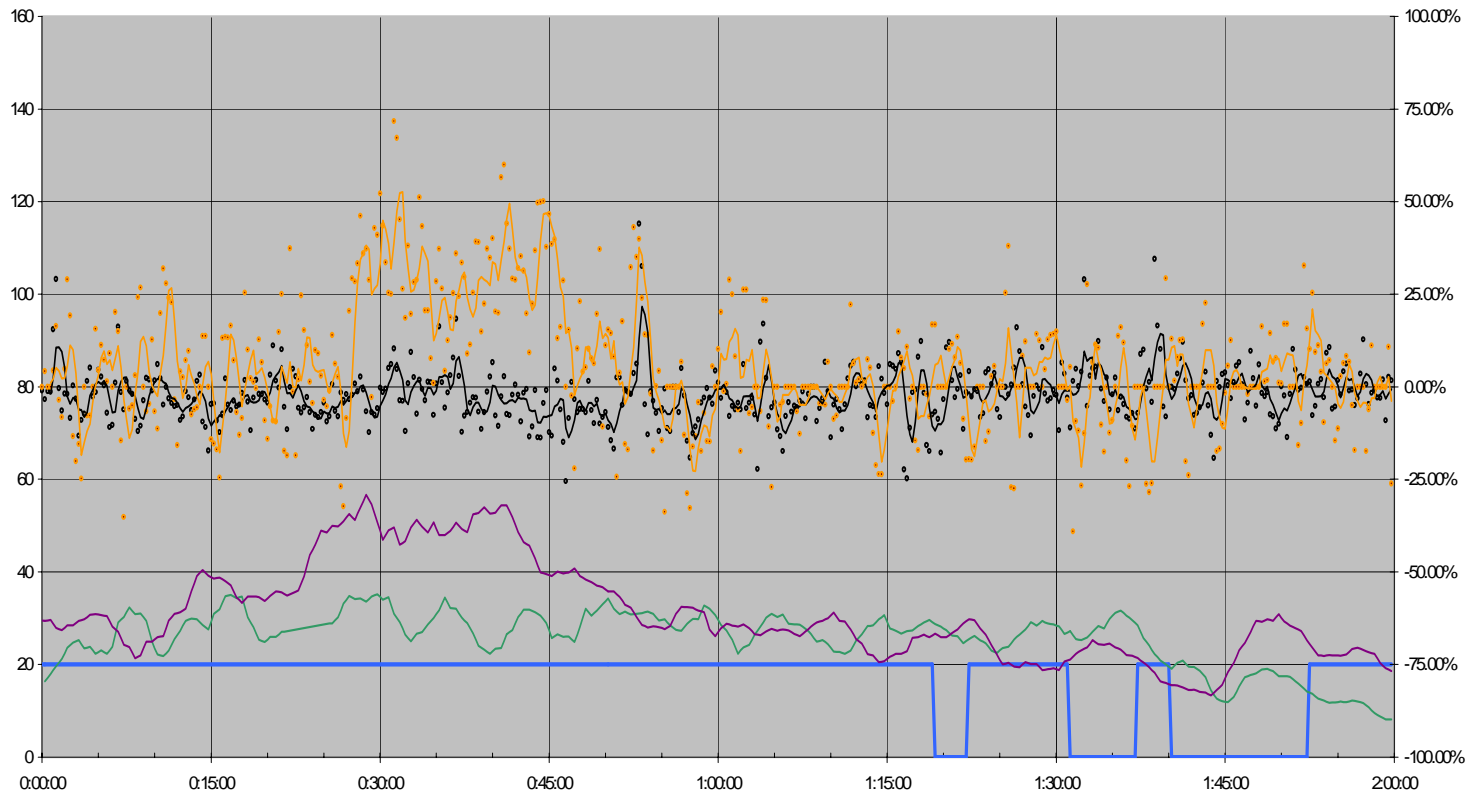
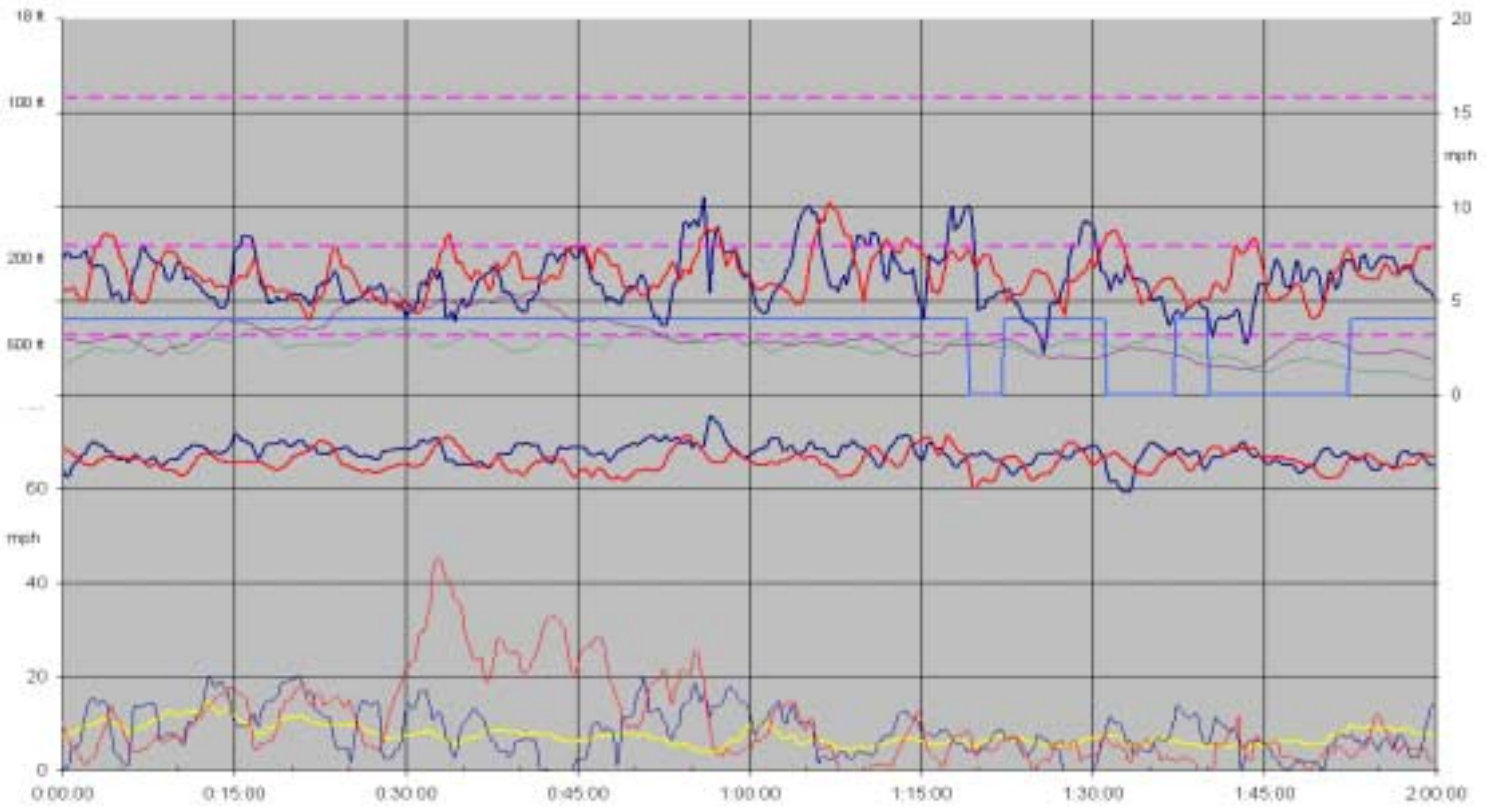

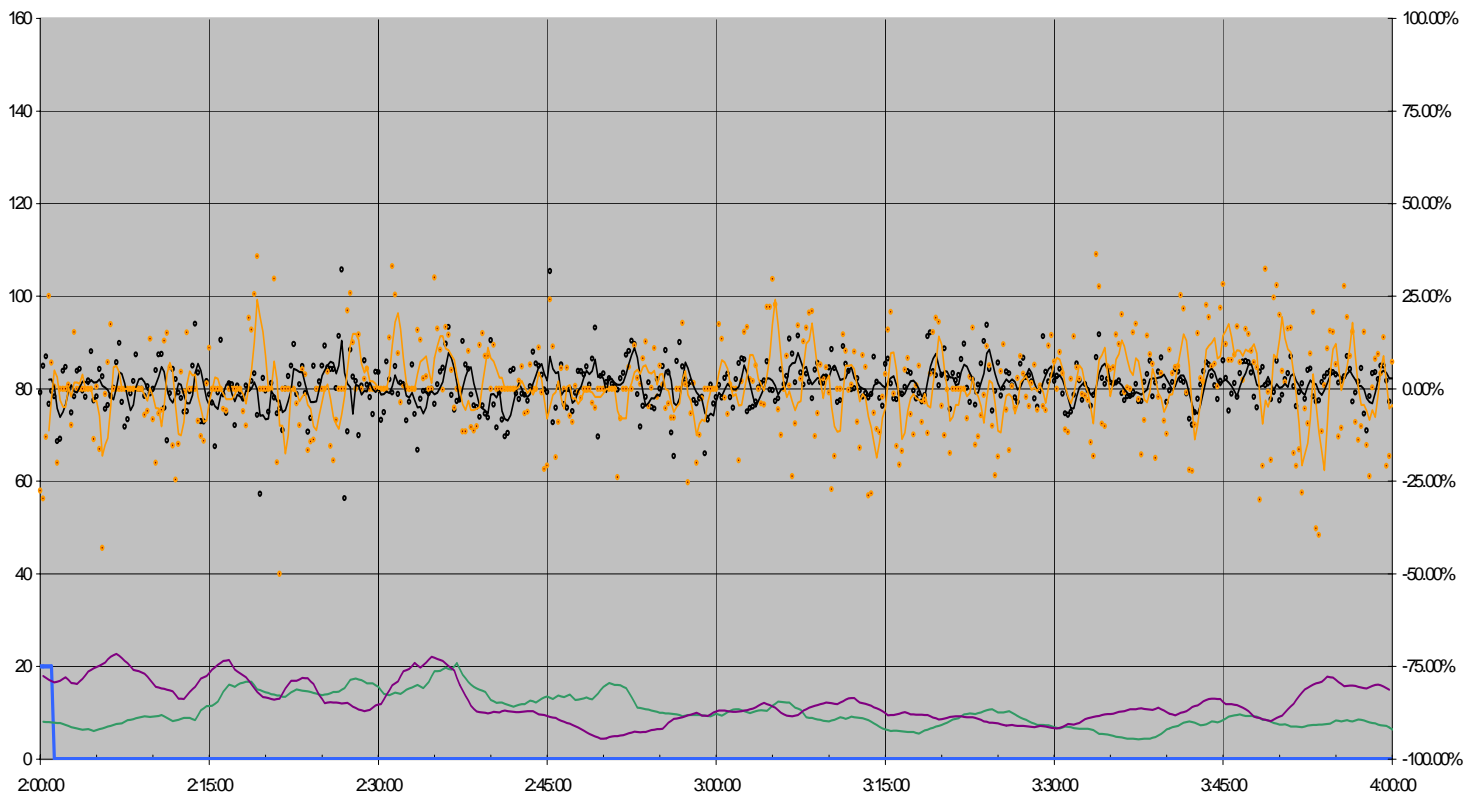

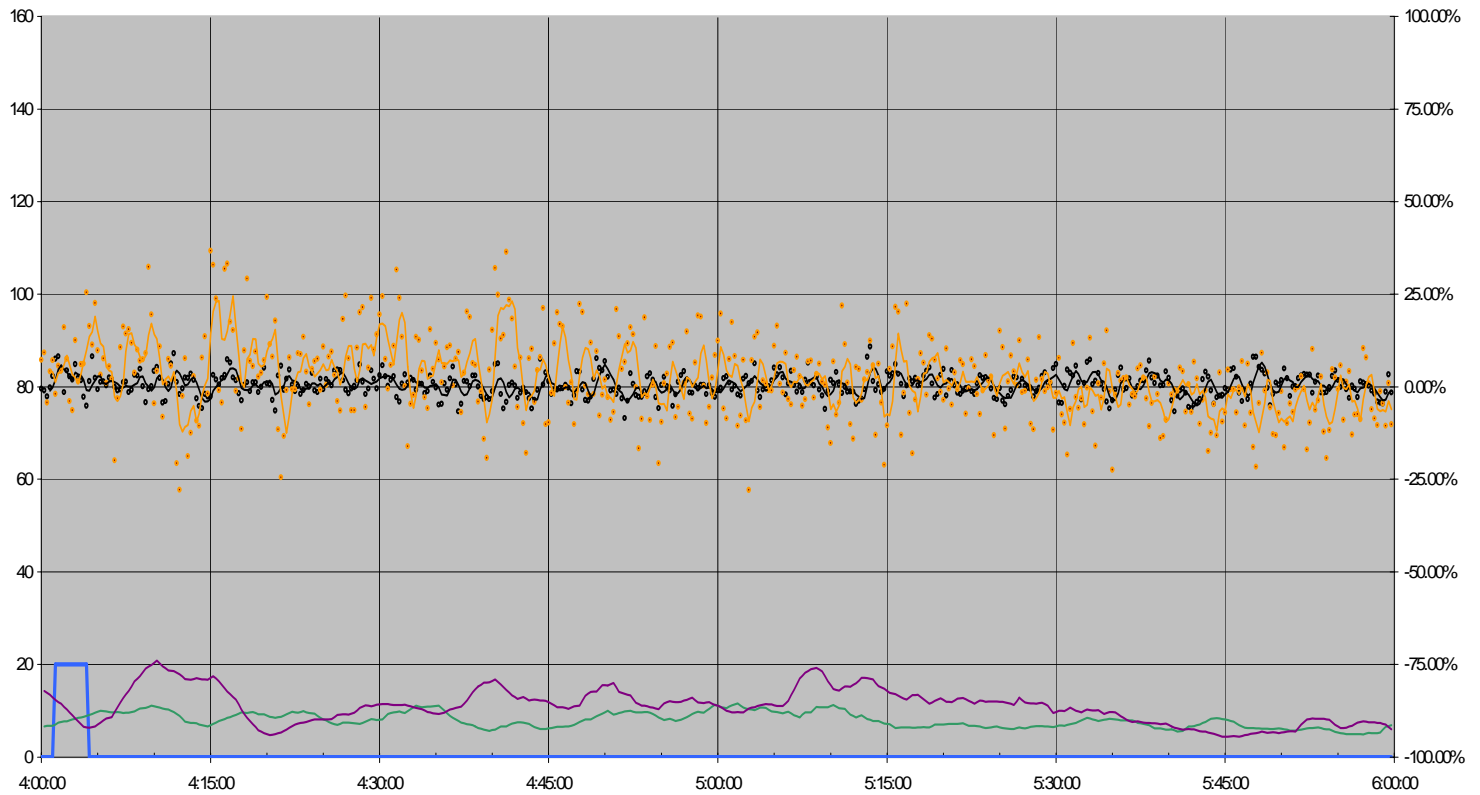
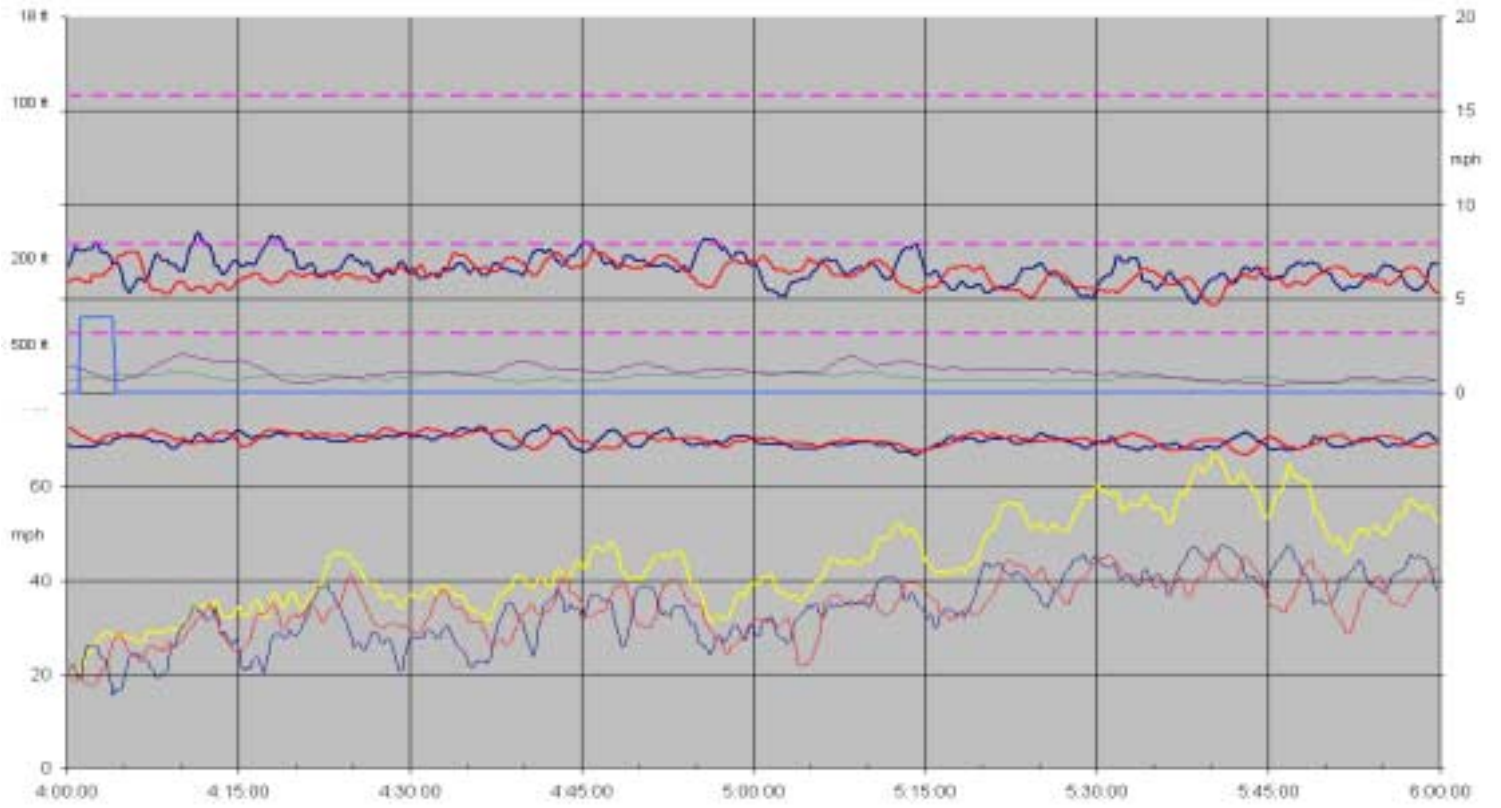



Page 1 of CMS message



Page 2 of CMS message



Sample traffic image

Figure 2.8.1.12. CMS 2-page message and sample traffic during event, from evaluation video camera.

Table 2.8.1.11. Normalized differences, After-CMS sites VS Before-CMS sites, during constant message periods.

Start Time (mo/day/yr hr:min)	Period (sec)	CMS Messages	Speed (mph)			Stddev (mph)			Norm PCS (%)			Volume (Veh/Hr)			Vis (Extinction Coef)		
			BCMS	ACMS	%chg	BCMS	ACMS	%chg	BCMS	ACMS	%chg	BCMS	ACMS	%chg	BCMS	ACMS	%chg
12/19/2004 20:49	170	DENSE FOG/ADVISE 45 MPH	72.06	71.18	-1.22	7.17	6.35	-11.44	44.81	49	9.35	4193	4405	5.05	7.55	10.98	45.43
12/19/2004 20:52	170	BLANK MESSAGE	71.88	70.39	-2.07	7.02	6.35	-9.54	38.85	34.61	-10.91	3304	2922	-11.54	5.66	13.69	141.87
12/19/2004 21:22	1810	DENSE FOG/ADVISE 45 MPH	70.71	68.6	-2.98	7.73	6.64	-14.1	36.15	39.89	10.35	3065	3174	3.57	8.19	34.49	321.12
12/19/2004 21:58	550	BLANK MESSAGE	70.14	68.77	-1.95	7.65	7.38	-3.53	30.31	30.25	-0.2	2428	2612	7.55	17.28	25.57	47.97
12/19/2004 22:07	550	DENSE FOG/ADVISE 45 MPH	69.54	68.82	-1.04	7.05	6.55	-7.09	27.44	30.58	11.44	2461	2801	13.83	17.96	30.16	67.93
12/19/2004 23:46	364	BLANK MESSAGE	69.23	66.44	-4.03	6.91	6.94	0.43	15.4	18.73	21.62	485	890	83.67	16.7	32.62	95.33
12/19/2004 23:52	364	DENSE FOG/ADVISE 45 MPH	70.52	67.55	-4.21	8.53	7.18	-15.83	15.84	24.59	55.24	584	1088	86.44	20.71	34.66	67.36
12/20/2004 1:19	190	BLANK MESSAGE	67.82	64.49	-4.91	9.17	7.52	-17.99	8.37	13.41	60.22	834	777	-6.82	27.72	28.4	2.45
12/20/2004 1:22	190	DENSE FOG/ADVISE 45 MPH	64.25	62.99	-1.96	6.16	7.07	14.77	11.62	2.26	-80.55	853	758	-11.11	24.52	22.1	-9.87
12/20/2004 1:31	370	BLANK MESSAGE	64.97	65.48	0.78	8.51	6.56	-22.91	11.24	8.43	-25	778	691	-11.25	28.07	22.84	-18.63
12/20/2004 1:37	170	DENSE FOG/ADVISE 45 MPH	66.75	66.69	-0.09	7.57	6.88	-9.11	16.03	0	-100	741	635	-14.29	25.15	16.08	-36.06
12/20/2004 1:40	170	BLANK MESSAGE	66.64	68.55	2.87	4.21	8.71	106.89	15.4	10.56	-31.43	635	699	10	19.89	14.08	-29.21
12/20/2004 1:52	528	DENSE FOG/ADVISE 45 MPH	66.21	65.73	-0.72	7.97	7.3	-8.41	10.69	11.24	5.14	1016	1084	6.71	11.13	20.52	84.37
12/20/2004 2:01	528	BLANK MESSAGE	66.62	66.83	0.32	7.26	7.09	-2.34	11.24	8.44	-24.91	559	593	6.1	7.47	18.7	150.33
12/20/2004 4:01	169	DENSE FOG/ADVISE 45 MPH	68.82	70.88	2.99	7.73	6.8	-12.03	37.83	39.91	5.5	3323	3707	11.54	7.68	7.29	-5.08
12/20/2004 4:04	169	BLANK MESSAGE	70.55	71.3	1.06	7.24	6.87	-5.11	29.11	36.97	27	2940	3323	13.04	9.44	11.85	25.53

Table 2.8.1.12. Normalized change in metrics measured during period 15 minutes after vs period 15 minutes before each message transition.

CMS TRANSITION			Speed (mph)			Stddev (mph)			Norm PCS (%)			Volume (Veh/Hr)			Vis (Extinction Coef)		
Time of Transition		CMS Message	BCMS	ACMS	%chg	BCMS	ACMS	%chg	BCMS	ACMS	%chg	BCMS	ACMS	%chg	BCMS	ACMS	%chg
12/19/2004 20:49	PRE	BLANK MESSAGE	71.01	71.92	1.28	7.31	6.62	-9.44	41.66	37.88	-9.07	3875	3727	-3.83	8.68	18.77	116.24
	POST	DENSE FOG/ADVISE 45 MPH	72.06	71.18	-1.22	7.17	6.35	-11.44	44.81	49	9.35	4193	4405	5.05	7.55	10.98	45.43
		Period Size: 170s		1.48	-1.03	-2.47	-1.92	-4.08	-2.21	7.56	29.36	20.26	8.2	18.18	9.23	-13.02	-41.5
12/19/2004 20:52	PRE	DENSE FOG/ADVISE 45 MPH	72.06	71.18	-1.22	7.17	6.35	-11.44	44.81	49	9.35	4193	4405	5.05	7.55	10.98	45.43
	POST	BLANK MESSAGE	71.88	70.39	-2.07	7.02	6.35	-9.54	38.85	34.61	-10.91	3304	2922	-11.54	5.66	13.69	141.87
		Period Size: 170s		-0.25	-1.11	-0.86	-2.09	0	2.14	-13.3	-29.37	-18.53	-21.21	-33.65	-15.79	-25.03	24.68
12/19/2004 21:22	PRE	BLANK MESSAGE	71.76	70.24	-2.12	7.43	6.1	-17.9	42.45	48.59	14.46	3696	3948	6.82	7.73	29.62	283.18
	POST	DENSE FOG/ADVISE 45 MPH	70.1	69.56	-0.77	7.36	6.62	-10.05	38.9	42.03	8.05	3288	3480	5.84	7.57	29.56	290.49
		Period Size: 300s		-2.31	-0.97	1.38	-0.94	8.52	9.56	-8.36	-13.5	-5.61	-11.04	-11.85	-0.92	-2.07	-0.2
12/19/2004 21:58	PRE	DENSE FOG/ADVISE 45 MPH	69.67	68.06	-2.31	7.88	6.89	-12.56	31.56	35.89	13.72	3060	2928	-4.31	13.16	18.05	37.16
	POST	BLANK MESSAGE	70.64	68.02	-3.71	7.84	7.51	-4.21	30.51	27.12	-11.11	2400	2388	-0.5	15.8	24.76	56.71
		Period Size: 300s		1.39	-0.06	-1.43	-0.51	9	9.55	-3.33	-24.44	-21.84	-21.57	-18.44	3.99	20.06	37.17

12/19/2004 22:07	PRE	BLANK MESSAGE	69.6	68.95	-0.93	7.25	7.47	3.03	28.76	32.68	13.63	2364	2748	16.24	18.39	27.19	47.85
	POST	DENSE FOG/ADVISE 45 MPH	69.28	68.2	-1.56	6.93	6.37	-8.08	28.73	29.55	2.85	2436	2904	19.21	19.44	33.85	74.13
	Period Size: 300s		-0.46	-1.09	-0.63	-4.41	-14.73	-10.79	-0.1	-9.58	-9.48	3.05	5.68	2.55	5.71	24.49	17.77
12/19/2004 23:46	PRE	DENSE FOG/ADVISE 45 MPH	69.55	69.1	-0.65	10.41	7.95	-23.63	24.01	15.46	-35.61	708	1188	67.8	20.39	19.77	-3.04
	POST	BLANK MESSAGE	69.09	66.48	-3.78	7.05	7.09	0.57	15.27	21.07	37.98	540	960	77.78	16.58	31.26	88.54
	Period Size: 300s		-0.66	-3.79	-3.15	-32.28	-10.82	31.69	-36.4	36.29	114.29	-23.73	-19.19	5.95	-18.69	58.12	94.45
12/19/2004 23:52	PRE	BLANK MESSAGE	69.93	67.28	-3.79	7.16	6.85	-4.33	9.96	16.45	65.16	456	900	97.37	17.3	34.52	99.54
	POST	DENSE FOG/ADVISE 45 MPH	70.33	67.28	-4.34	8.73	7.33	-16.04	16.26	25.76	58.43	636	1152	81.13	19.81	35.55	79.45
	Period Size: 300s		0.57	0	-0.57	21.93	7.01	-12.24	63.25	56.6	-4.08	39.47	28	-8.23	14.51	2.98	-10.06
12/20/2004 1:19	PRE	DENSE FOG/ADVISE 45 MPH	66.32	66.58	0.39	9.72	10.92	12.35	10.3	7.65	-25.73	777	663	-14.63	27.65	26.06	-5.75
	POST	BLANK MESSAGE	67.82	64.49	-4.91	9.17	7.52	-17.99	8.37	13.41	60.22	834	777	-6.82	27.72	28.4	2.45
	Period Size: 190s		2.26	-3.14	-5.28	-5.66	-31.14	-27.01	-18.74	75.29	115.71	7.32	17.14	9.16	0.25	8.98	8.7
12/20/2004 1:22	PRE	BLANK MESSAGE	67.82	64.49	-4.91	9.17	7.52	-17.99	8.37	13.41	60.22	834	777	-6.82	27.72	28.4	2.45
	POST	DENSE FOG/ADVISE 45 MPH	64.25	62.99	-1.96	6.16	7.07	14.77	11.62	2.26	-80.55	853	758	-11.11	24.52	22.1	-9.87
	Period Size: 190s		-5.26	-2.33	3.1	-32.82	-5.98	39.96	38.83	-83.15	-87.86	2.27	-2.44	-4.61	-11.54	-22.18	-12.03
12/20/2004 1:31	PRE	DENSE FOG/ADVISE 45 MPH	68.26	67.33	-1.36	8.59	8.52	-0.81	2.77	9.42	240.07	708	756	6.78	27.59	20.3	-26.42
	POST	BLANK MESSAGE	63.67	65.67	3.14	8.88	6.9	-22.3	12.8	7.97	-37.73	768	684	-10.94	27.45	23.42	-14.68
	Period Size: 300s		-6.72	-2.47	4.57	3.38	-19.01	-21.66	362.09	-15.39	-81.69	8.47	-9.52	-16.59	-0.51	15.37	15.96
12/20/2004 1:37	PRE	BLANK MESSAGE	69.09	66.56	-3.66	6.74	6.44	-4.45	7.42	5.61	-24.39	762	784	2.78	30.2	21.39	-29.17
	POST	DENSE FOG/ADVISE 45 MPH	66.75	66.69	-0.09	7.57	6.88	-9.11	16.03	0	-100	741	635	-14.29	25.15	16.08	-36.06
	Period Size: 170s		-3.39	0.2	3.71	12.31	6.83	-4.88	116.04	-100	-100	-2.78	-18.92	-16.6	-16.72	-24.82	-9.73
12/20/2004 1:40	PRE	DENSE FOG/ADVISE 45 MPH	66.75	66.69	-0.09	7.57	6.88	-9.11	16.03	0	-100	741	635	-14.29	25.15	16.08	-36.06
	POST	BLANK MESSAGE	66.64	68.55	2.87	4.21	8.71	106.89	15.4	10.56	-31.43	635	699	10	19.89	14.08	-29.21
	Period Size: 170s		-0.16	2.79	2.96	-44.39	26.6	127.64	-3.93	und	und	-14.29	10	28.33	-20.91	-12.44	10.72
12/20/2004 1:52	PRE	BLANK MESSAGE	66.06	64.63	-2.16	7.8	7.35	-5.77	1.84	5.64	206.52	660	804	21.82	17.64	27.37	55.16
	POST	DENSE FOG/ADVISE 45 MPH	66.01	65.42	-0.89	8.22	6.89	-16.18	10.62	14.98	41.05	1152	1248	8.33	12.42	22.5	81.16
	Period Size: 300s		-0.08	1.22	1.3	5.38	-6.26	-11.05	477.17	165.6	-53.98	74.55	55.22	-11.07	-29.59	-17.79	16.76
12/20/2004 2:01	PRE	DENSE FOG/ADVISE 45 MPH	66.02	66.01	-0.02	7.52	8.05	7.05	10.52	7.47	-28.99	888	960	8.11	10.1	18.93	87.43
	POST	BLANK MESSAGE	65.15	65.75	0.92	6.95	7.08	1.87	10.58	9.74	-7.94	576	624	8.33	7	19.62	180.29
	Period Size: 300s		-1.32	-0.39	0.94	-7.58	-12.05	-4.84	0.57	30.39	29.65	-35.14	-35	0.21	-30.69	3.65	49.54
12/20/2004 4:01	PRE	BLANK MESSAGE	70.3	70.91	0.87	7.72	6.67	-13.6	32.65	29	-11.18	2556	2599	1.67	7.22	12.37	71.33
	POST	DENSE FOG/ADVISE 45 MPH	68.82	70.88	2.99	7.73	6.8	-12.03	37.83	39.91	5.5	3323	3707	11.54	7.68	7.29	-5.08
	Period Size: 169s		-2.11	-0.04	2.11	0.13	1.95	1.82	15.87	37.62	18.78	30	42.62	9.71	6.37	-41.07	-44.6
12/20/2004 4:04	PRE	DENSE FOG/ADVISE 45 MPH	68.82	70.88	2.99	7.73	6.8	-12.03	37.83	39.91	5.5	3323	3707	11.54	7.68	7.29	-5.08
	POST	BLANK MESSAGE	70.55	71.3	1.06	7.24	6.87	-5.11	29.11	36.97	27	2940	3323	13.04	9.44	11.85	25.53
	Period Size: 169s		2.51	0.59	-1.87	-6.34	1.03	7.87	-23.05	-7.37	20.38	-11.54	-10.34	1.35	22.92	62.55	32.25

2.8.2 Traffic (Speed-actuated) Events

In the following selected typical events, CMS 1 actuated due to speed-related conditions at one or both of the two subsequent speed monitoring sites, Mathews Road or Traffic Monitoring Site 1B.

2.8.2.1 March 13, 2004, Time: 9am-11am

Synopsis:

A moving traffic blockage triggers the CMS with a "SLOW TRAFFIC AHEAD" message, after a delay of approximately 15 minutes.

Files:

2004-03-13-fog-event.xls, 2004-03-13-constant-message-intervals.xls, 2004-03-13-message-transitions.xls

Narrative:

A moving traffic blockage due to a multi-lane platoon of slow-moving vehicles was detected by our instrumentation at the BCMS sites at approximately 9:20 AM. Speed conditions BCMS returned to normal within 5 minutes. The disturbance propagated to the ACMS sites that actuate CMS 1 for traffic conditions. It was first detected at 9:22 AM, and was returned to normal by 9:35 AM. At 9:31, the mean speed ACMS was 40 mph. The CMS activated at 9:39 AM with a "SLOW TRAFFIC AHEAD" message, after a delay of approximately 15 minutes subsequent to conditions at Mathews Road which were sufficient for activation of the message. By this time, traffic had returned to normal, at least 1.1 miles down-road of the CMS, although the disturbance would have propagated further down the highway.

PCS increased at the BCMS site when the blockage was detected there. PCS did not significantly increase ACMS when the blockage passed through. Speed standard deviation increased during the passage of the blockage from the usual 6% to as high as 17% at the ACMS sites, but increased to only 8% at the BCMS sites. Since the CMS was not activated until well after these detection times, we were observing the natural response of drivers. Drivers slowing for the obstruction obviously did so non-homogeneously, thus increasing the spread of vehicle speeds as detected by the moving standard deviation window. Apparently, the greater the slow down, the greater the spread of speeds.

During the period in which the CMS message was active, there were no measurable changes in any metrics from their normal uncongested values. In fact, mean speed increased a normalized 2% during the activation of the message compared with the period immediately prior to this transition (see Table 2.8.2.2). This appears to confirm observations from the fog activations of the CMS that drivers respond to their own perceptions of traffic and environmental conditions and completely disregard a warning message unless it is consistent with their immediate observations.

Figure 2.8.2.1. Time history of event in two-hour increments (series of plots below).

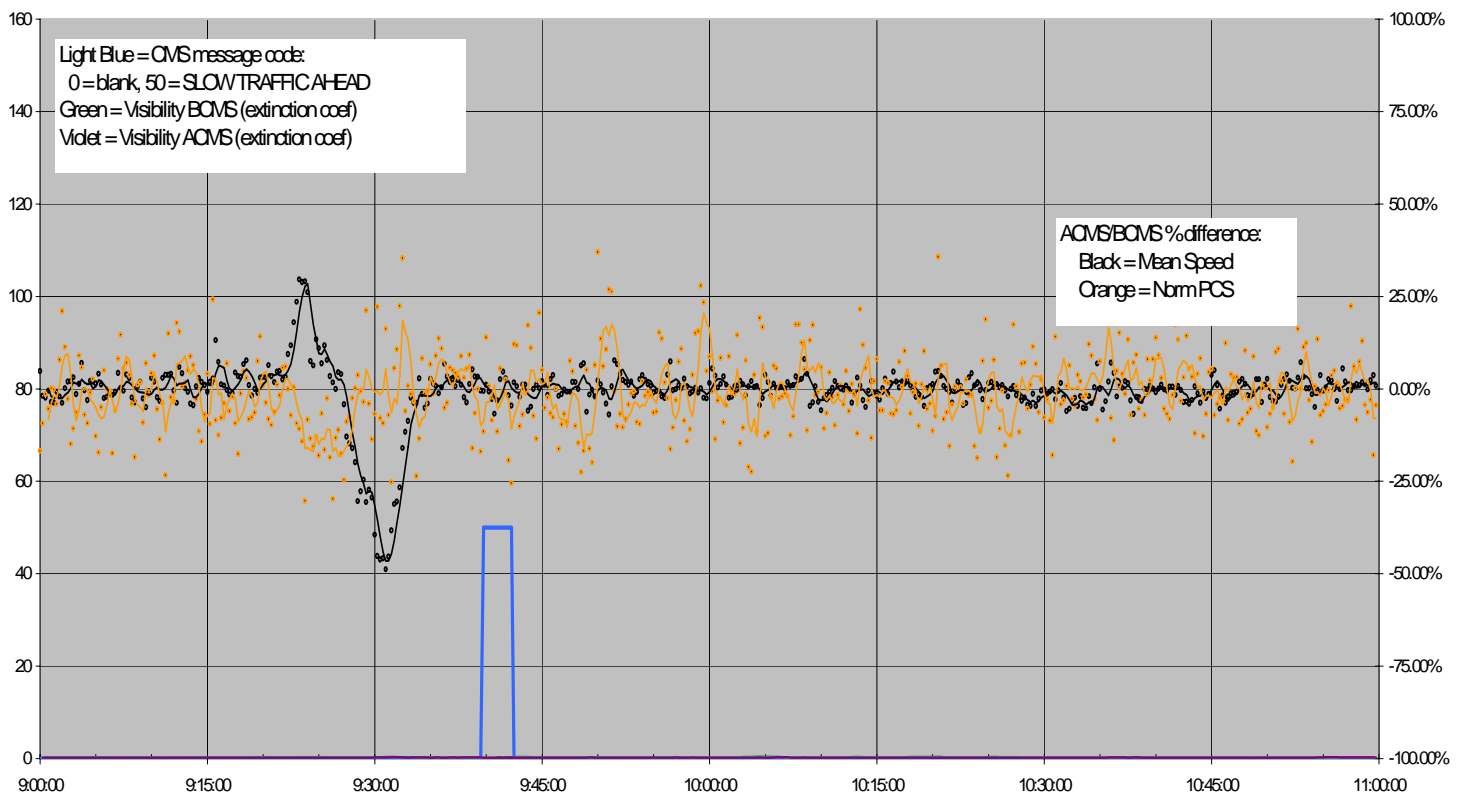
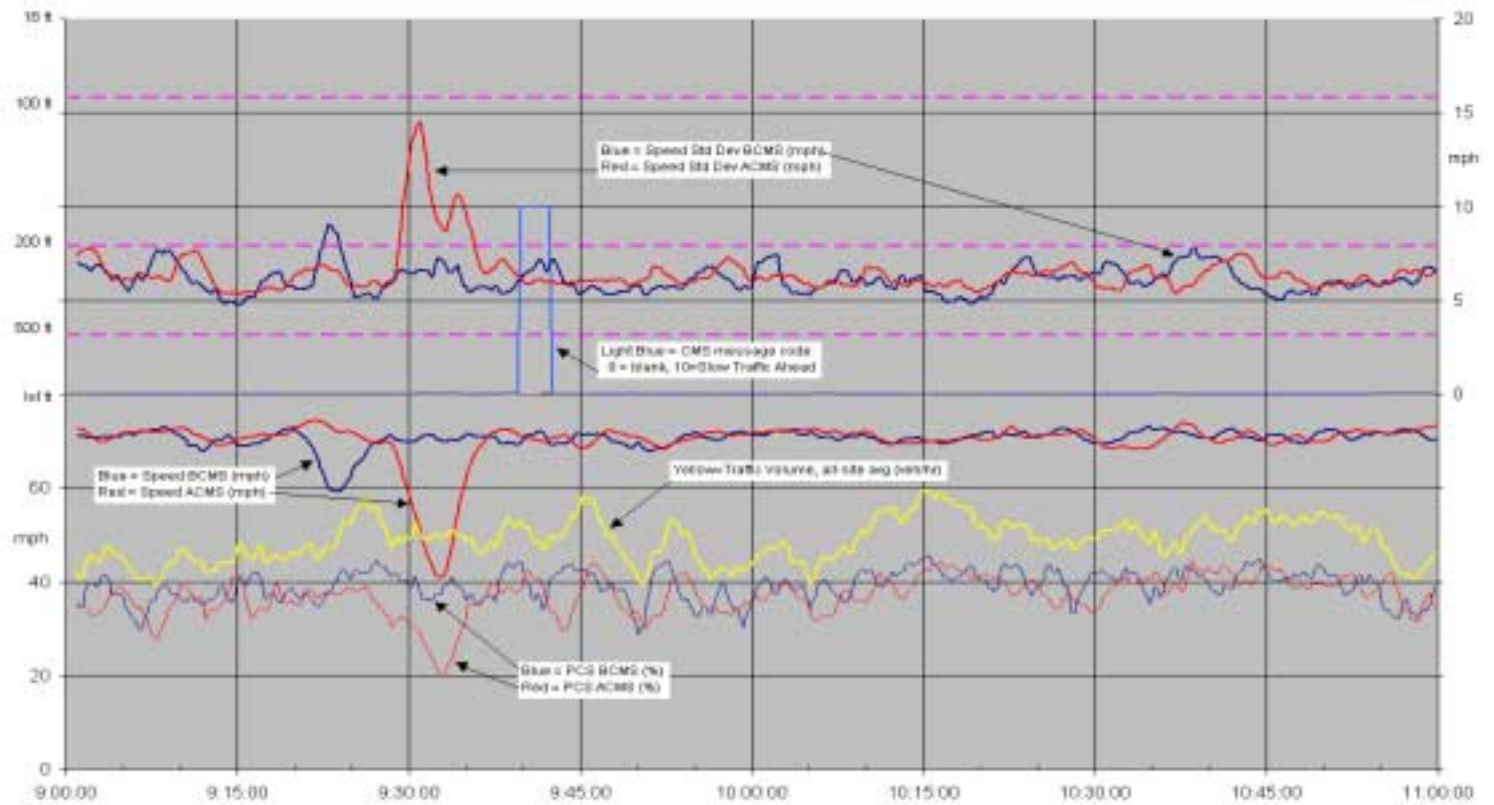



Page 1 of CMS message



Page 2 of CMS message



Sample traffic image

Figure 2.8.2.2. CMS 2-page message and traffic while message was displayed at 9:41 AM, from evaluation video cameras.

Table 2.8.2.1. Normalized differences, After-CMS sites VS Before-CMS sites, during constant message periods.

Start Time (mo/day/yr hr:min)	Period (sec)	CMS Messages	Speed (mph)			Stddev (mph)			Norm PCS (%)			Volume (Veh/Hr)			Vis (Extinction Coef)		
			BCMS	ACMS	%chg	BCMS	ACMS	%chg	BCMS	ACMS	%chg	BCMS	ACMS	%chg	BCMS	ACMS	%chg
3/13/2004 9:39	170	SLOW TRAFFIC AHEAD/CAUTION	70.34	70.43	0.13	6.72	6.15	-8.48	59.06	55.4	-6.2	6289	5802	-7.74	0.24	0.26	8.33
3/13/2004 9:42	170	BLANK MESSAGE	69.98	69.04	-1.34	7.18	6.34	-11.7	62.08	59.74	-3.77	6755	6162	-8.78	0.37	0.22	-40.54

Table 2.8.2.2. Normalized change in metrics measured during period 15 minutes after vs period 15 minutes before each message transition.

CMS TRANSITION			Speed (mph)			Stddev (mph)			Norm PCS (%)			Volume (Veh/Hr)			Vis (Extinction Coef)		
Time of Transition		CMS Message	BCMS	ACMS	%chg	BCMS	ACMS	%chg	BCMS	ACMS	%chg	BCMS	ACMS	%chg	BCMS	ACMS	%chg
3/13/2004 9:39	PRE	BLANK MESSAGE	70.26	71.73	2.09	5.92	6.76	14.19	57.56	60.21	4.6	6120	5824	-4.84	0.19	0.27	42.11
	POST	SLOW TRAFFIC AHEAD/CAUTION	70.34	70.43	0.13	6.72	6.15	-8.48	59.06	55.4	-6.2	6289	5802	-7.74	0.24	0.26	8.33
		Period Size: 170s		0.11	-1.81	-1.92	13.51	-9.02	-19.85	2.61	-7.99	-10.33	2.77	-0.36	-3.05	26.32	-3.7
3/13/2004 9:42	PRE	SLOW TRAFFIC AHEAD/CAUTION	70.34	70.43	0.13	6.72	6.15	-8.48	59.06	55.4	-6.2	6289	5802	-7.74	0.24	0.26	8.33
	POST	BLANK MESSAGE	69.98	69.04	-1.34	7.18	6.34	-11.7	62.08	59.74	-3.77	6755	6162	-8.78	0.37	0.22	-40.54
		Period Size: 170s		-0.51	-1.97	-1.47	6.85	3.09	-3.52	5.11	7.83	2.59	7.41	6.2	-1.12	54.17	-15.38

2.8.2.2 April 17, 2004, Time: 5pm-7pm

Synopsis:

Large speed reduction ACMS, due to down-road accident. Heavy rain conditions.

Data collection system status:**Files:**

2004-04-17-fog-event.xls, 2004-04-17-constant-message-intervals.xls, 2004-04-17-message-transitions.xls

Narrative:

Major traffic blockage at ACMS sites starting at 5:15 PM. CMS message activates at 5:32 PM with STOPPED TRAFFIC AHEAD based on triggers from speed sites 1A and 1B, which are also the ACMS evaluation monitoring sites. BCMS sites relatively unaffected. Speed standard deviation hits maximum of 25 mph at 5:30 during slow-down period. Mean speed ACMS down to 10 mph at 5:37 PM.

Average volume was 40 vehicles/minute for duration of event.

ACMS PCS falls almost to zero mph along with the speed reduction, and returns to pre-event level of 50% of the mean speed after speed increases again, even while CMS message is still displayed. Conditions return to normal by approximately 6:00 PM. CMS deactivates at 6:11, after brief period of displaying SLOW TRAFFIC AHEAD. The overlap period in which the CMS message was still displayed but the traffic conditions had returned to normal can be compared with the previous period in which the mean speed was low and the message was displayed.

Mean speed was 70 mph at BCMS sites only 1.2 miles from ACMS sites where speeds were as low as 10 mph. It is possible that the warning message helped to facilitate a more gradual slow down in this short period. But since speed returned to normal and PCS increased as traffic obstruction cleared, even though CMS message was still displayed, there it is unclear if drivers responded to the CMS message or just their personal perceptions of the degrading traffic conditions. Traffic was already slowing abruptly ACMS when the CMS was activated. At the time of activation, traffic flow at the CMS site was normal, as can be seen from the surveillance camera image of Figure 2.8.2.4.

Figure 2.8.2.3. Time history of event in two-hour increments (series of plots below).

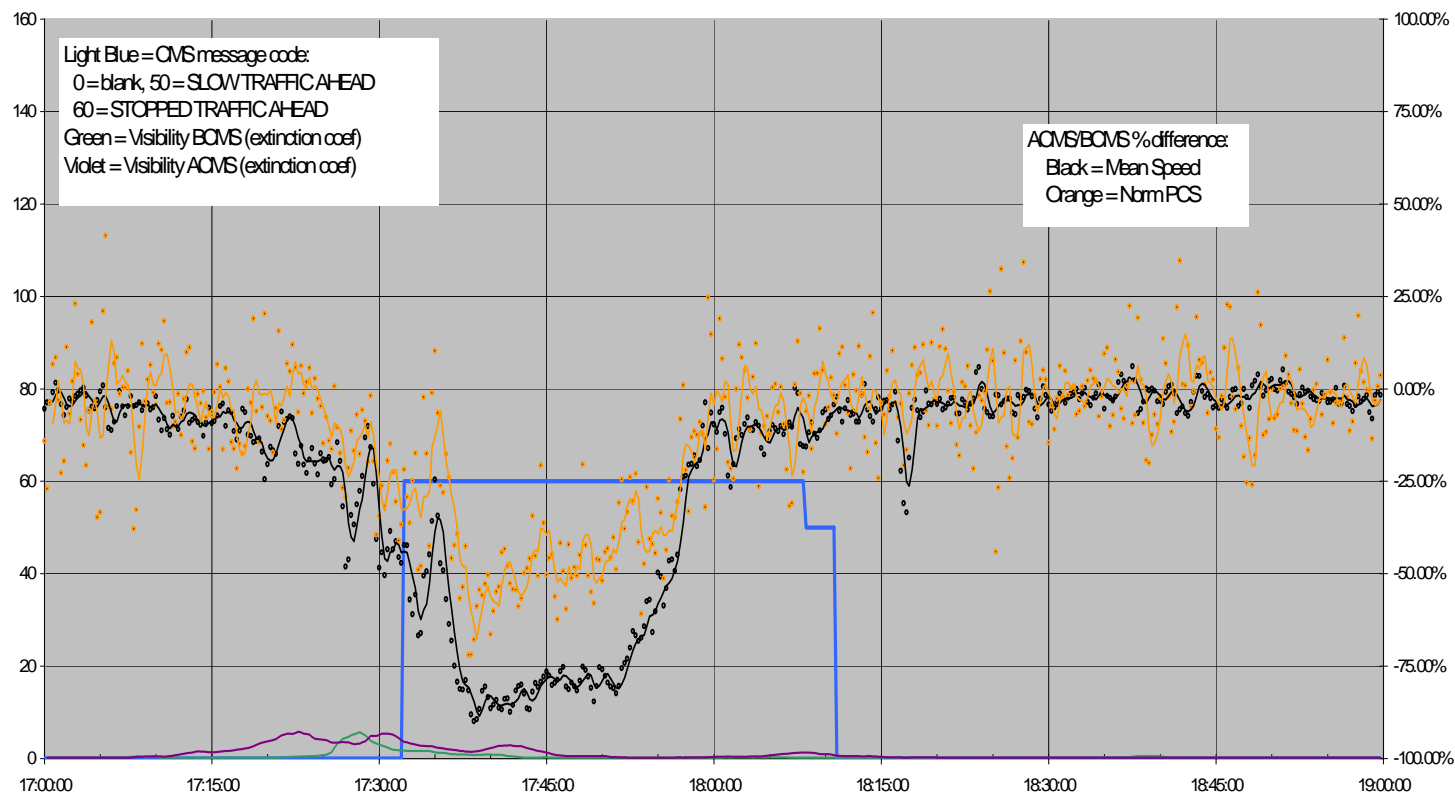
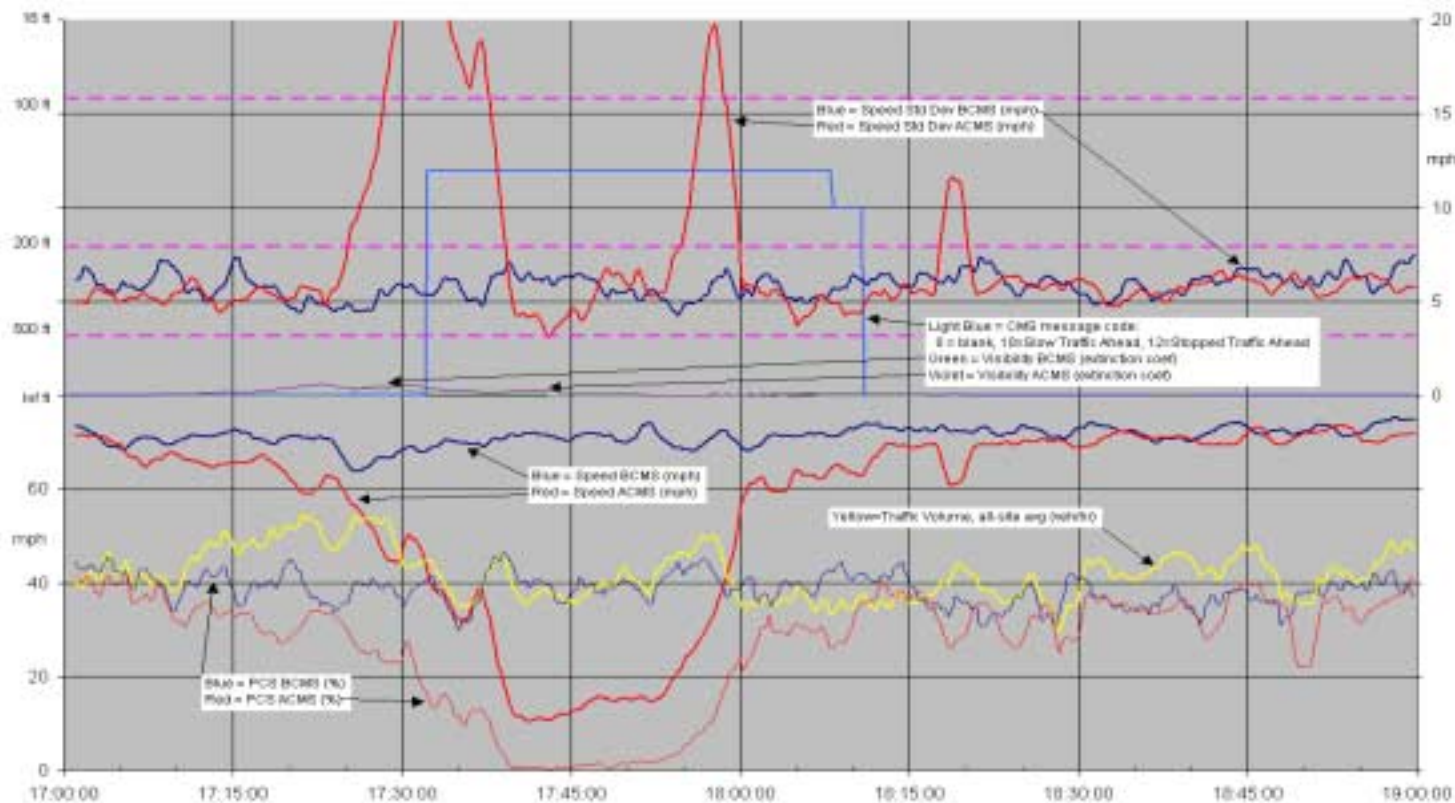



Sample traffic image

Figure 2.8.2.4. Traffic at CMS site while CMS message was displayed, from evaluation video cameras.

Table 2.8.2.3. Normalized differences, After-CMS sites VS Before-CMS sites, during constant message periods.

Start Time (mo/day/yr hr:min)	Period (sec)	CMS Messages	Speed (mph)			Stddev (mph)			Norm PCS (%)			Volume (Veh/Hr)			Vis (Extinction Coef)		
			BCMS	ACMS	%chg	BCMS	ACMS	%chg	BCMS	ACMS	%chg	BCMS	ACMS	%chg	BCMS	ACMS	%chg
4/17/2004 17:32	2157	STOPPED TRAFFIC AHEAD/CAUTION	70.59	30.54	-56.74	6.27	21.76	247.05	58.93	23.46	-60.19	6042	3468	-42.6	0.5	1.07	114
4/17/2004 18:08	170	SLOW TRAFFIC AHEAD/CAUTION	72	63.91	-11.24	6.16	5.94	-3.57	62.73	60.21	-4.02	5929	2965	-50	0.17	0.77	352.94
4/17/2004 18:10	170	BLANK MESSAGE	73.82	69.31	-6.11	6.69	5.34	-20.18	55.81	55.8	-0.02	5591	2626	-53.03	0.18	0.48	166.67

Table 2.8.2.4. Normalized change in metrics measured during period 15 minutes after VS period 15 minutes before each message transition.

CMS TRANSITION			Speed (mph)			Stddev (mph)			Norm PCS (%)			Volume (Veh/Hr)			Vis (Extinction Coef)		
Time of Transition		CMS Message	BCMS	ACMS	%chg	BCMS	ACMS	%chg	BCMS	ACMS	%chg	BCMS	ACMS	%chg	BCMS	ACMS	%chg
4/17/2004 17:32	PRE	BLANK MESSAGE	67.01	44.38	-33.77	5.98	22.56	277.26	60.23	38.95	-35.33	6684	4332	-35.19	3.93	4.39	11.7
	POST	STOPPED TRAFFIC AHEAD/CAUTION	69.32	34.8	-49.8	5.97	19.76	230.99	55.71	28.81	-48.29	5844	3492	-40.25	1.53	2.13	39.22
	Period Size: 300s			3.45	-21.59	-24.2	-0.17	-12.41	-12.26	-7.5	-26.03	-20.03	-12.57	-19.39	-7.8	-61.07	-51.48
4/17/2004 18:08	PRE	STOPPED TRAFFIC AHEAD/CAUTION	71.33	63.96	-10.33	5.34	5.68	6.37	57.17	45.72	-20.03	6289	2605	-58.59	0.28	1.25	346.43
	POST	SLOW TRAFFIC AHEAD/CAUTION	72	63.91	-11.24	6.16	5.94	-3.57	62.73	60.21	-4.02	5929	2965	-50	0.17	0.77	352.94
	Period Size: 170s			0.94	-0.08	-1.01	15.36	4.58	-9.34	9.73	31.69	20.02	-5.72	13.82	20.73	-39.29	-38.4
4/17/2004 18:10	PRE	SLOW TRAFFIC AHEAD/CAUTION	72	63.91	-11.24	6.16	5.94	-3.57	62.73	60.21	-4.02	5929	2965	-50	0.17	0.77	352.94
	POST	BLANK MESSAGE	73.82	69.31	-6.11	6.69	5.34	-20.18	55.81	55.8	-0.02	5591	2626	-53.03	0.18	0.48	166.67
	Period Size: 170s			2.53	8.45	5.78	8.6	-10.1	-17.22	-11.03	-7.32	4.17	-5.71	-11.43	-6.06	5.88	-37.66

2.8.2.3 June 28, 2004, Time: 4am-6am

Synopsis:

Activation of two-level traffic warning in early morning hours, but no speed conditions observed ACMS. A useful baseline for observing reaction of drivers in the absence of any influence of local traffic conditions.

Files:

2004-6-28-fog-event.xls, 2004-6-28-constant-message-intervals.xls, 2004-6-28-message-transitions.xls

Narrative:

Activation of traffic warning between 4:15 and 4:21 AM, and 4:27 and 4:38 AM. Speed conditions at ACMS do not indicate a sufficient trigger condition for CMS actuation. Actuation due to trigger conditions at sites 2A and 2B, well down-road of the CMS. Light rain. This event provides a baseline for observing reaction of drivers to both levels of warning message in the absence of any influence of local traffic conditions.

No measurable change in any metrics during period of CMS message compared with adjoining time periods.

Interesting side observation: PCS slowly creeps up from approximately 20 mph at 4:00 AM to approximately 40 mph at 6:00 AM, with both BCMS and ACMS sites approximately equal. During this period traffic volume also increased from approximately 35 vehicles per minute at 4:00 AM to 60 vehicles per minute at 6:00 AM. The day/night sensor indicated daytime light level at approximately 5:30 AM. This may suggest that drivers take greater risks (drive more closely for a given speed) as traffic volume increases and light levels increase.

Figure 2.8.2.5. Time history of event in two-hour increments (series of plots below).

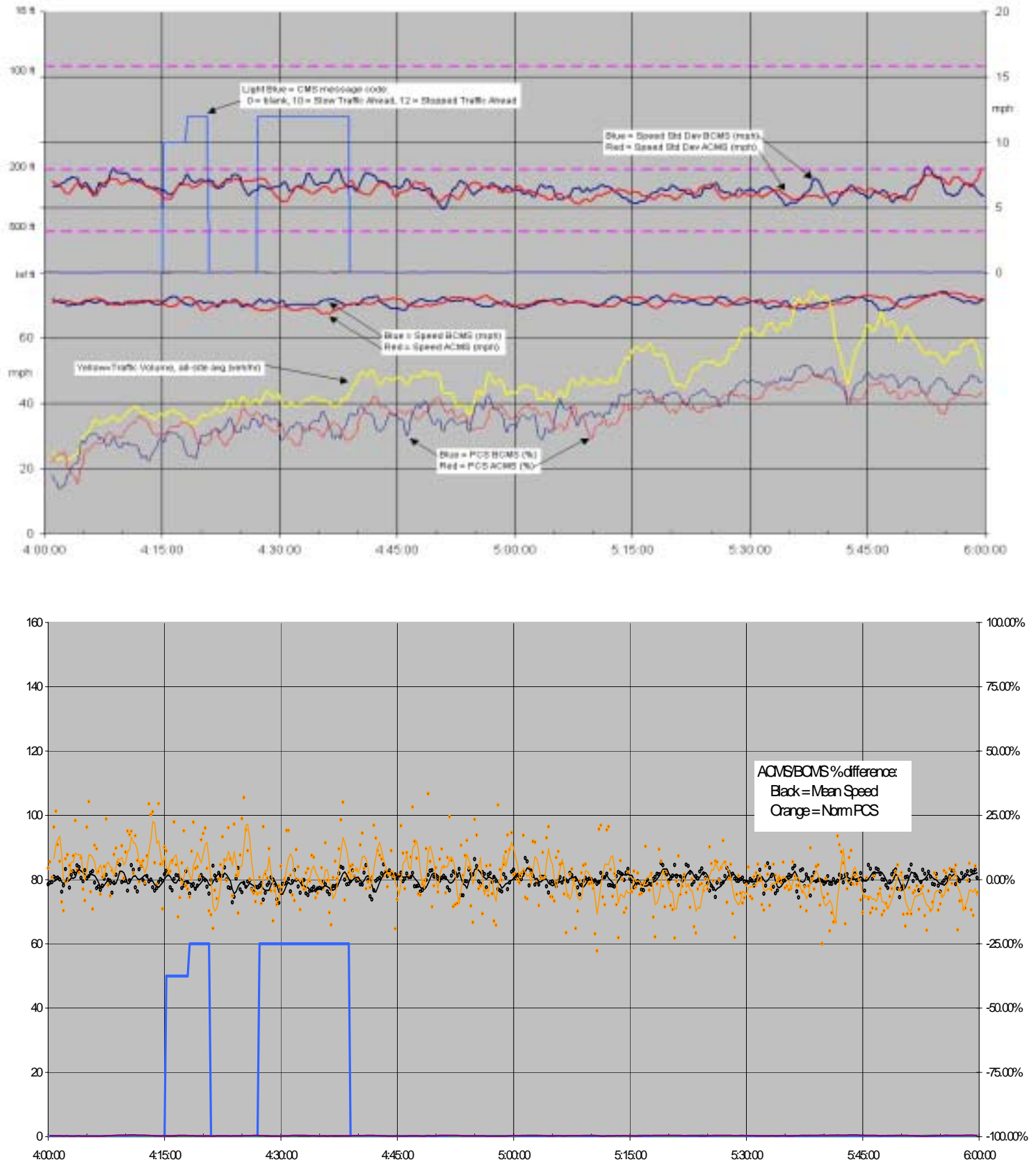



Page 1 of CMS message



Page 2 of CMS message



Page 3 of CMS message



Sample traffic image

Figure 2.8.2.6. CMS 3-page message and sample traffic during event, from evaluation video cameras.

Table 2.8.2.5. Normalized differences, After-CMS sites VS Before-CMS sites, during constant message periods.

Start Time (mo/day/yr hr:min)	Period (sec)	CMS Messages	Speed (mph)			Stddev (mph)			Norm PCS (%)			Volume (Veh/Hr)			Vis (Extinction Coef)		
			BCMS	ACMS	%chg	BCMS	ACMS	%chg	BCMS	ACMS	%chg	BCMS	ACMS	%chg	BCMS	ACMS	%chg
6/28/2004 4:15	179	SLOW TRAFFIC AHEAD/CAUTION	71.92	71.72	-0.28	6.54	6.94	6.12	45.21	47.6	5.29	4425	4485	1.36	0.26	0.36	38.46
6/28/2004 4:18	170	STOPPED TRAFFIC AHEAD/CAUTION	70.05	69.37	-0.97	7.48	7.12	-4.81	35.02	42.86	22.39	3875	4299	10.93	0.16	0.27	68.75
6/28/2004 4:20	170	BLANK MESSAGE	70.24	70.89	0.93	7.1	7.03	-0.99	48.4	49.31	1.88	4405	5104	15.87	0.19	0.29	52.63
6/28/2004 4:27	370	STOPPED TRAFFIC AHEAD/CAUTION	70.94	69.17	-2.5	6.82	6.21	-8.94	50.36	49.32	-2.07	4962	4923	-0.78	0.23	0.33	43.48
6/28/2004 4:38	710	BLANK MESSAGE	70.62	70.71	0.13	7.18	6.41	-10.72	53.68	57.6	7.3	5826	5816	-0.17	0.3	0.32	6.67

Table 2.8.2.6. Normalized change in metrics measured during period 15 minutes after vs period 15 minutes before each message transition.

CMS TRANSITION			Speed (mph)			Stddev (mph)			Norm PCS (%)			Volume (Veh/Hr)			Vis (Extinction Coef)		
Time of Transition		CMS Message	BCMS	ACMS	%chg	BCMS	ACMS	%chg	BCMS	ACMS	%chg	BCMS	ACMS	%chg	BCMS	ACMS	%chg
6/28/2004 4:15	PRE	BLANK MESSAGE	71.21	70.78	-0.6	7.11	6.12	-13.92	35.76	45.93	28.44	3982	4465	12.12	0.25	0.3	20
	POST	SLOW TRAFFIC AHEAD/CAUTION	71.92	71.72	-0.28	6.54	6.94	6.12	45.21	47.6	5.29	4425	4485	1.36	0.26	0.36	38.46
	Period Size: 179s			1	1.33	0.33	-8.02	13.4	23.28	26.43	3.64	-18.03	11.11	0.45	-9.59	4	20
6/28/2004 4:18	PRE	SLOW TRAFFIC AHEAD/CAUTION	72.12	71.93	-0.26	6.5	6.95	6.92	45.32	46.43	2.45	4447	4468	0.48	0.26	0.36	38.46
	POST	STOPPED TRAFFIC AHEAD/CAUTION	70.05	69.37	-0.97	7.48	7.12	-4.81	35.02	42.86	22.39	3875	4299	10.93	0.16	0.27	68.75
	Period Size: 170s			-2.87	-3.56	-0.71	15.08	2.45	-10.98	-22.73	-7.69	19.46	-12.86	-3.79	10.4	-38.46	-25
6/28/2004 4:20	PRE	STOPPED TRAFFIC AHEAD/CAUTION	70.05	69.37	-0.97	7.48	7.12	-4.81	35.02	42.86	22.39	3875	4299	10.93	0.16	0.27	68.75
	POST	BLANK MESSAGE	70.24	70.89	0.93	7.1	7.03	-0.99	48.4	49.31	1.88	4405	5104	15.87	0.19	0.29	52.63
	Period Size: 170s			0.27	2.19	1.91	-5.08	-1.26	4.02	38.21	15.05	-16.76	13.66	18.72	4.45	18.75	7.41
6/28/2004 4:27	PRE	BLANK MESSAGE	70.51	69.86	-0.92	7.38	7.34	-0.54	46.87	53.55	14.25	4248	5064	19.21	0.19	0.33	73.68
	POST	STOPPED TRAFFIC AHEAD/CAUTION	71.08	68.98	-2.95	6.96	6.3	-9.48	48.44	46.86	-3.26	4692	4776	1.79	0.23	0.32	39.13
	Period Size: 300s			0.81	-1.26	-2.05	-5.69	-14.17	-8.99	3.35	-12.49	-15.33	10.45	-5.69	-14.61	21.05	-3.03
6/28/2004 4:38	PRE	STOPPED TRAFFIC AHEAD/CAUTION	70.97	69.16	-2.55	7.35	6.98	-5.03	46.38	48.44	4.44	4572	4812	5.25	0.26	0.31	19.23
	POST	BLANK MESSAGE	71.32	71.14	-0.25	7.44	6.46	-13.17	53.97	58.02	7.5	5796	6000	3.52	0.27	0.32	18.52
	Period Size: 300s			0.49	2.86	2.36	1.22	-7.45	-8.57	16.36	19.78	2.93	26.77	24.69	-1.64	3.85	3.23

2.8.2.4 September 15, 2004, Time: 4pm-6pm

Synopsis:

Highway advisory CMS activation.

Data collection system status:**Files:**

2004-09-15-fog-event.xls, 2004-09-15-constant-message-intervals.xls, 2004-09-15-message-transitions.xls

Narrative:

CMS 1 activated from 4:22 PM to 4:33 pm with a CAUTION, HIGHWAY ADVISORY AHEAD message due to speed trigger conditions at one or more of sites 2C, 2D, 3A or 3B. Traffic volume was moderate at approximately 60 vehicles/minute for the duration of the event.

A minor reduction in normalized speed (-.69%) and significant increase in normalized standard deviation (+21.3%) occurred immediately after the display of the message. The reverse of this occurred in normalized speed (+2.77%) and normalized standard deviation (-1.03%) immediately after the CMS was extinguished. This observation suggests that a few drivers slowed to read the message, but most did not. This decreased the mean speed, but increased the speed standard deviation. If this is true, then it wasn't the message on the sign that mattered, but rather the driver response to the existence of a message that some would read and some would ignore.

There seemed to be a minor problem in either the message bulb map or the CMS itself, as can be seen in Figure 2.8.2.8.

Figure 2.8.2.7. Time history of event in two-hour increments (series of plots below).

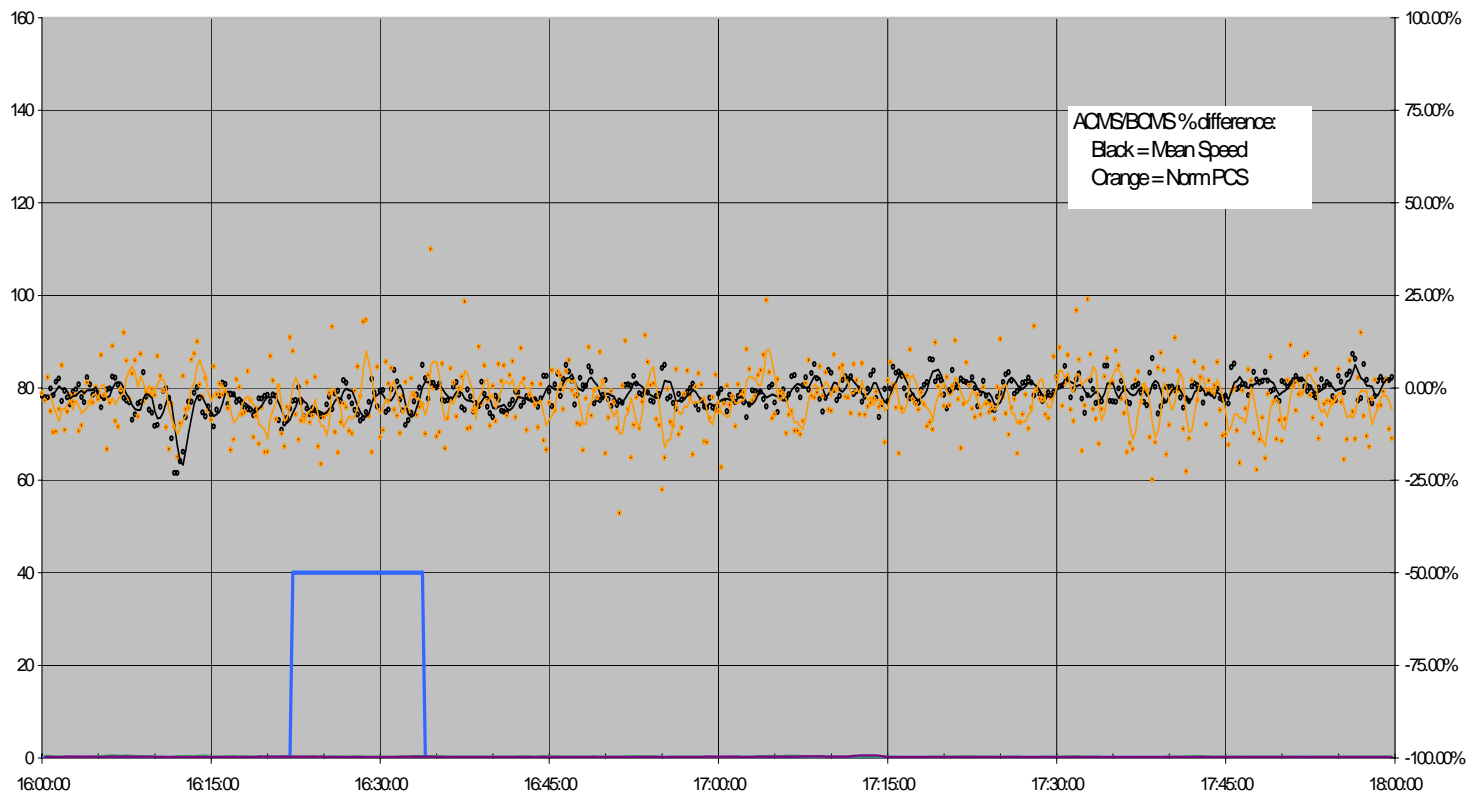
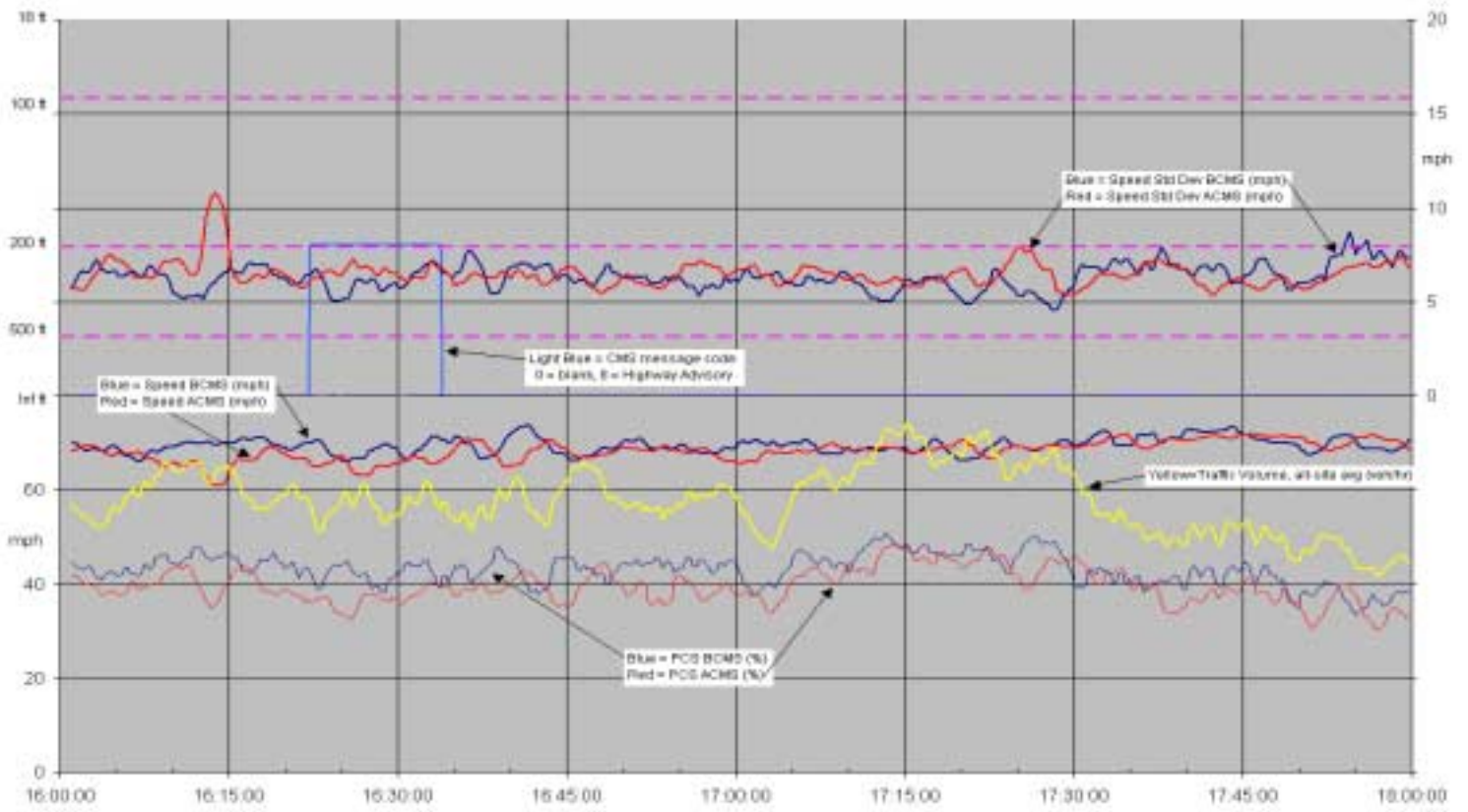



Page 1 of CMS message



Page 2 of CMS message



Sample traffic image

Figure 2.8.2.8. CMS 2-page message and traffic during message display, from evaluation video cameras.

Table 2.8.2.7. Normalized differences, After-CMS sites VS Before-CMS sites, during constant message periods.

Start Time (mo/day/yr hr:min)	Period (sec)	CMS Messages	Speed (mph)			Stddev (mph)			Norm PCS (%)			Volume (Veh/Hr)			Vis (Extinction Coef)		
			BCMS	ACMS	%chg	BCMS	ACMS	%chg	BCMS	ACMS	%chg	BCMS	ACMS	%chg	BCMS	ACMS	%chg
9/15/2004 16:22	710	HIGHWAY ADVISORY AHEAD/CAUTION	68.37	65.61	-4.04	6.82	7.14	4.69	65.09	59.89	-7.99	7175	6500	-9.4	0.3	0.2	-33.33
9/15/2004 16:33	710	BLANK MESSAGE	69.88	68.28	-2.29	7.4	6.99	-5.54	64.77	61.39	-5.22	7190	6546	-8.96	0.32	0.16	-50

Table 2.8.2.8. Normalized change in metrics measured during period 15 minutes after vs period 15 minutes before each message transition.

CMS TRANSITION			Speed (mph)			Stddev (mph)			Norm PCS (%)			Volume (Veh/Hr)			Vis (Extinction Coef)		
Time of Transition		CMS Message	BCMS	ACMS	%chg	BCMS	ACMS	%chg	BCMS	ACMS	%chg	BCMS	ACMS	%chg	BCMS	ACMS	%chg
9/15/2004 16:22	PRE	BLANK MESSAGE	70.19	67.21	-4.25	6.88	6.7	-2.62	65.57	58.9	-10.17	6912	6732	-2.6	0.32	0.22	-31.25
	POST	HIGHWAY ADVISORY AHEAD/CAUTION	68.08	64.74	-4.91	6.23	7.36	18.14	65.81	58.54	-11.05	7260	6528	-10.08	0.3	0.2	-33.33
		Period Size: 300s		-3.01	-3.68	-0.69	-9.45	9.85	21.31	0.37	-0.61	-0.97	5.03	-3.03	-7.68	-6.25	-9.09
9/15/2004 16:33	PRE	HIGHWAY ADVISORY AHEAD/CAUTION	69.15	66.76	-3.46	7.44	6.81	-8.47	63.8	60.7	-4.86	7140	6504	-8.91	0.29	0.22	-24.14
	POST	BLANK MESSAGE	69.34	68.8	-0.78	7.65	6.93	-9.41	63.49	58.87	-7.28	6804	6120	-10.05	0.33	0.18	-45.45
		Period Size: 300s		0.27	3.06	2.77	2.82	1.76	-1.03	-0.49	-3.01	-2.54	-4.71	-5.9	-1.26	13.79	-18.18

2.8.3 Wind event

2.8.3.1 April 28, 2004, Time: 5pm-7pm

Synopsis:

Gusty Wind Warning activation, clear weather, afternoon rush hour.

Data collection system status:**Files:**

2005-04-28-fog-event.xls, 2005-04-28-constant-message-intervals.xls, 2005-04-28-message-transitions.xls

Narrative:

From 5:47 PM to 5:50 PM (one Signview polling cycle) the CMS displayed GUSTY WIND WARNING. Normalized speed decreased slightly on both transitions of the message (OFF->ON= -1.63%, ON->OFF= -0.83%), which is not significant. Normalized speed standard deviation increased slightly when the message was displayed (+4.47%) and decreased (-1.47%) after the message was extinguished, although the raw standard deviation numbers behind these changes were all in the range of 7-8 mph, so this is also not significant. Normalized PCS decreased – 18.52% when the message was displayed, and increased +7.9% when the message was blanked. These observations may indicate some incremental effect on traffic, as a slight decrease in mean speed and PCS but a slight increase in the spread of speeds. The net effect on traffic safety seemed to be positive, but small.

Figure 2.8.3.1. Time history of event in two-hour increments (series of plots below).

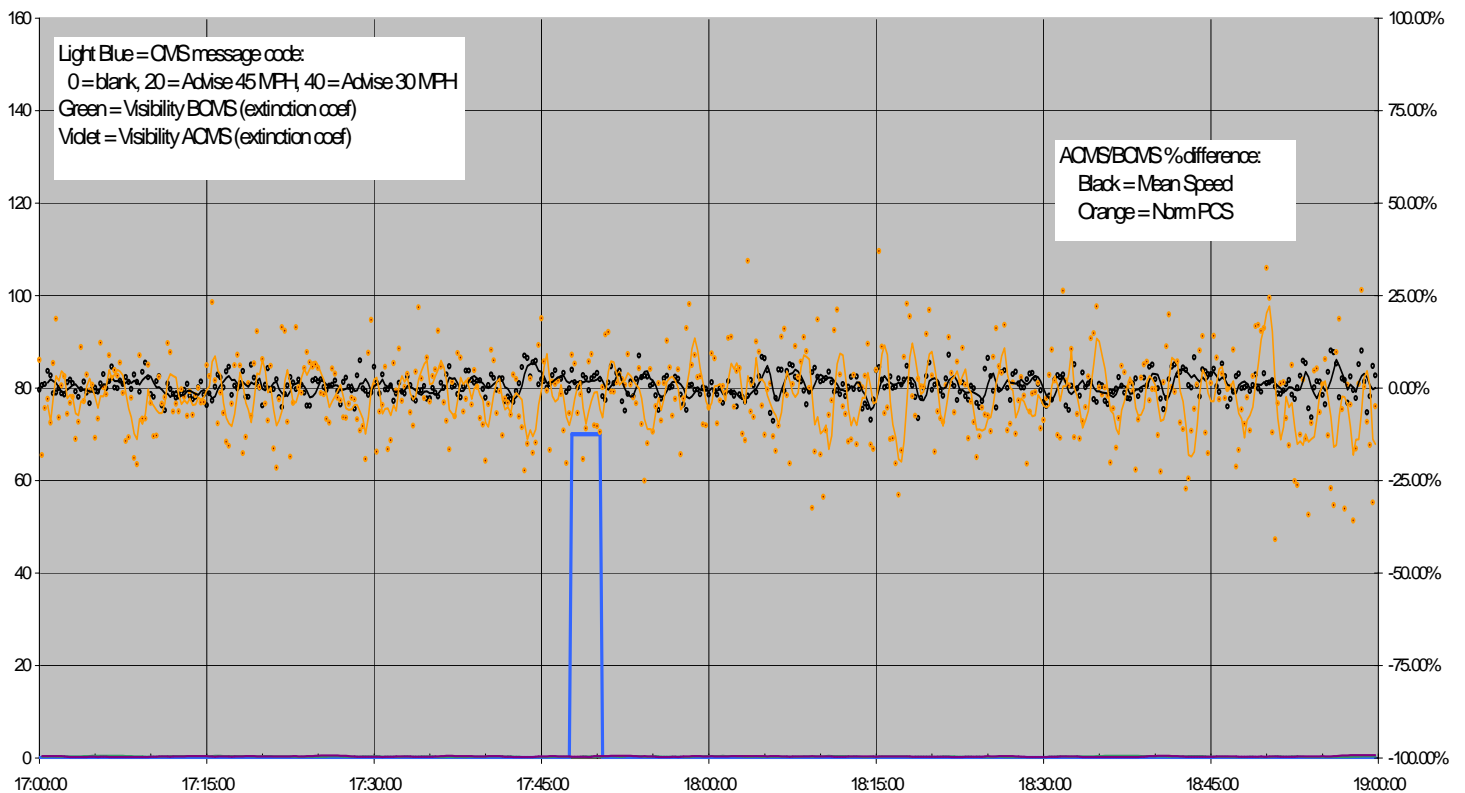
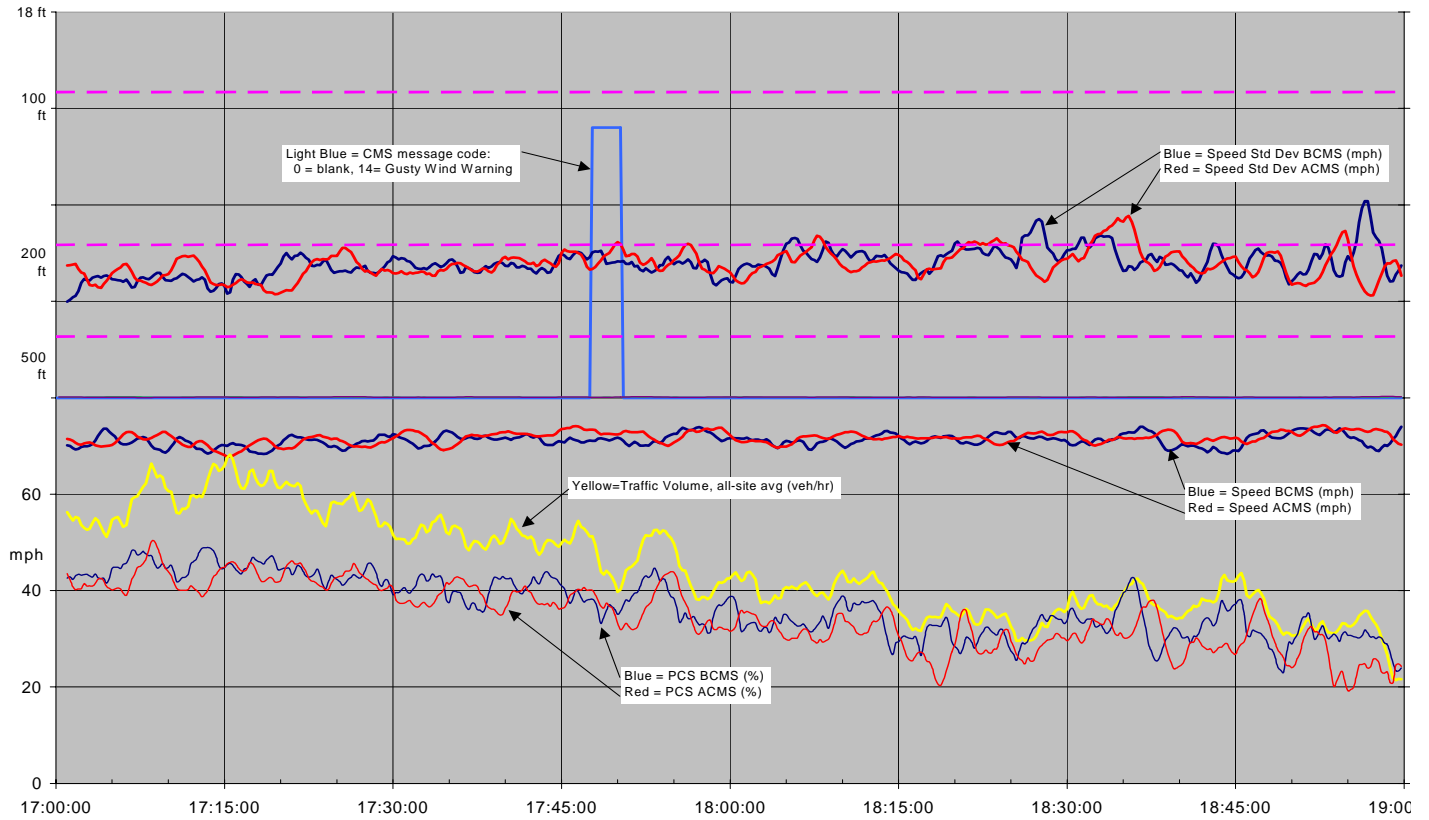



Figure 2.8.3.2. CMS message and traffic during display of message, from evaluation video cameras. (The CMS image is actually from another wind activation due to camera problem during this event.)

Table 2.8.3.1. Normalized differences, After-CMS sites VS Before-CMS sites, during constant message periods.

Start Time (mo/day/yr hr:min)	Period (sec)	CMS Messages	Speed (mph)			Stddev (mph)			Norm PCS (%)			Volume (Veh/Hr)			Vis (Extinction Coef)		
			BCMS	ACMS	%chg	BCMS	ACMS	%chg	BCMS	ACMS	%chg	BCMS	ACMS	%chg	BCMS	ACMS	%chg
4/28/2004 17:47	172	GUSTY WIND WARNING	71.18	72.59	1.98	7.88	7.92	0.51	53.71	48.52	-9.66	5547	4458	-19.62	0.31	0.39	25.81
4/28/2004 17:50	172	BLANK MESSAGE	70.57	71.37	1.13	7.22	7.15	-0.97	59.25	58.76	-0.83	6781	5881	-13.27	0.34	0.42	23.53

Table 2.8.3.2. Normalized change in metrics measured during period 15 minutes after vs period 15 minutes before each message transition.

CMS TRANSITION			Speed (mph)			Stddev (mph)			Norm PCS (%)			Volume (Veh/Hr)			Vis (Extinction Coef)		
Time of Transition		CMS Message	BCMS	ACMS	%chg	BCMS	ACMS	%chg	BCMS	ACMS	%chg	BCMS	ACMS	%chg	BCMS	ACMS	%chg
4/28/2004 17:47	PRE	BLANK MESSAGE	70.81	73.41	3.67	7.42	7.12	-4.04	59.62	57.24	-3.99	6174	6091	-1.36	0.26	0.33	26.92
	POST	GUSTY WIND WARNING	71.18	72.59	1.98	7.88	7.92	0.51	53.71	48.52	-9.66	5547	4458	-19.62	0.31	0.39	25.81
	Period Size: 172s			0.52	-1.12	-1.63	6.2	11.24	4.74	-9.91	-15.23	-5.91	-10.17	-26.8	-18.52	19.23	18.18
4/28/2004 17:50	PRE	GUSTY WIND WARNING	71.18	72.59	1.98	7.88	7.92	0.51	53.71	48.52	-9.66	5547	4458	-19.62	0.31	0.39	25.81
	POST	BLANK MESSAGE	70.57	71.37	1.13	7.22	7.15	-0.97	59.25	58.76	-0.83	6781	5881	-13.27	0.34	0.42	23.53
	Period Size: 172s			-0.86	-1.68	-0.83	-8.38	-9.72	-1.47	10.31	21.1	9.78	22.26	31.92	7.9	9.68	7.69

2.9 Observations over all events, 2003-2005

2.9.1 Speed, standard deviation of speed, and PCS as a function of visibility

In order better discern the natural response of drivers to fog from the supplemental effect of the CMS message, we now examine the relationship of each metric at each evaluation site as a function of visibility. This method of data display was used for mean speed by Hogema et al in their evaluation of the Dutch A16 system (3). Data covers the complete period 2003-05, although to avoid massively redundant data points during clear weather, we restricted the data set to the periods starting two hours prior to and ending two hours after each fog activation event. Even with this reduction in records, over 300,000 vehicles are considered in each plot, under conditions that were otherwise as consistent as possible. In the figures to follow, each graph contains four plotted data sets, one for each of the four evaluation test sites. The only difference between the ACMS and BCMS sites was the exposure of drivers to the CMS message for visibilities below 500 ft. just prior to the ACMS sites. A dotted red line shows the 500 ft. visibility limit.

If individual vehicle records of each metric are displayed on these plots, the scatter is overwhelming and obscures the actual trends. Efforts to fit conventional trend lines, such as by least squares polynomial fit, resulted in misleading graphics due to implicit force-fit of models of incorrect form for the phenomena were attempting to reveal. We therefore use a centered moving average window for a small range of visibilities, specifically +/- 1% range of the extinction coefficient at the given abscissa value of visibility (expressed on the plots as visibility distance for easier understanding). The moving visibility average window is incremented 1% for each new plotted point, from 100 ft to 10,000 ft visibility. The visibility axis (abscissa) is scaled logarithmically, which fairly distributed the individual vehicle data across the visibility span of each graph.

We examine each of the metrics: speed in mph, short-period standard deviation of speed in mph, and PCS in mph. The ordinate of each plot shows the values of each metric averaged over all drivers who were detected when the visibility was the given abscissa value. Each of the two BCMS and ACMS sites are plotted individually, as opposed to our prior convention of volume-averaging the two BCMS sites together and the two ACMS sites together. This allows a visual cross-check for data between each site in the pair. Since the two BCMS sites are only 0.1 miles apart, we expect all metrics measured at these sites to be nearly identical. The two ACMS sites are 0.5 miles apart, so somewhat greater variations in the data are possible between each. The second BCMS site and the first ACMS site are 1.2 miles distant, so much greater variations are expected between BCMS and ACMS sites as a group.

As can be seen from the mean speed plots, traffic naturally travels approximately 1 mph faster at the ACMS sites than at the BCMS sites. This small difference is probably due to a small influx of vehicles entering the freeway from the Downing Road on ramp, just ahead of the Downing Road evaluation site, and the relatively narrow bridge over French Camp Slough that lies between the two BCMS sites

(Downing Road and French Camp Slough). The first ACMS site, at Mathews Road, is comparatively a greater distance from the on ramp at French Camp Road, which lies between the CMS and the Mathews Road sites. The second ACMS evaluation test site, at El Dorado Overcrossing, is not proximate to any on- or offramps.

Since only the two ACMS sites benefited from the CMS message when visibility was below 500 ft., the potential affect of CMS message is revealed in these plots by examining the difference in the shape of the plot below 500 ft. for the ACMS vs. the BCMS sites (which were not influenced by the CMS). At all sites, data above 500 ft. visibility represents just the natural response of the drivers to that level of visibility.

We limited the visibility range of the plotted data to between 100 and 10,000 feet, although we had sparse data outside this range. The reasoning was that for visibilities below 100 feet, a CMS message would not have been activated during the first year of the study period, 2003-04. It was fixed in the second year 2004-05. For visibilities above 10,000 feet, the data is very noisy since the slightest atmospheric aberrations can cause the visibility sensors readings to fluctuate by thousands of feet. In this range, the extinction coefficient from which the distance is calculated is a very small fraction, and the digital quantization error starts to show up in the inverse calculation for distance. Visibilities over 10,000 feet (approximately two miles) may considered for traffic purposes to be unlimited.

The site numbers and color codes for these plots are as follows. BCMS = Before CMS. ACMS = After CMS. The evaluation site at the CMS for monitoring the CMS and mid-point traffic is Site No. 3.

Table 2.9.1.1. Plot line numbers and color codes for figures to follow.

Direction of traffic flow	Site No.	Color of plot line	Description	Site name	Distance from prior site
↓	4	Red	First BCMS site	Downing Road	N/A
	1	Yellow	Second BCMS site	French Camp Slough	0.1
	3		CMS site	CMS	1.2
	2	Green	First ACMS site	Mathews Road	0.5
	5	Blue	Second ACMS site	El Dorado Overcrossing	0.6

The non-sequential ordering of the site numbers was the result of legacy issues: the two inner evaluation sites were operational in 2002, while the two outer evaluation sites were completed a year later.

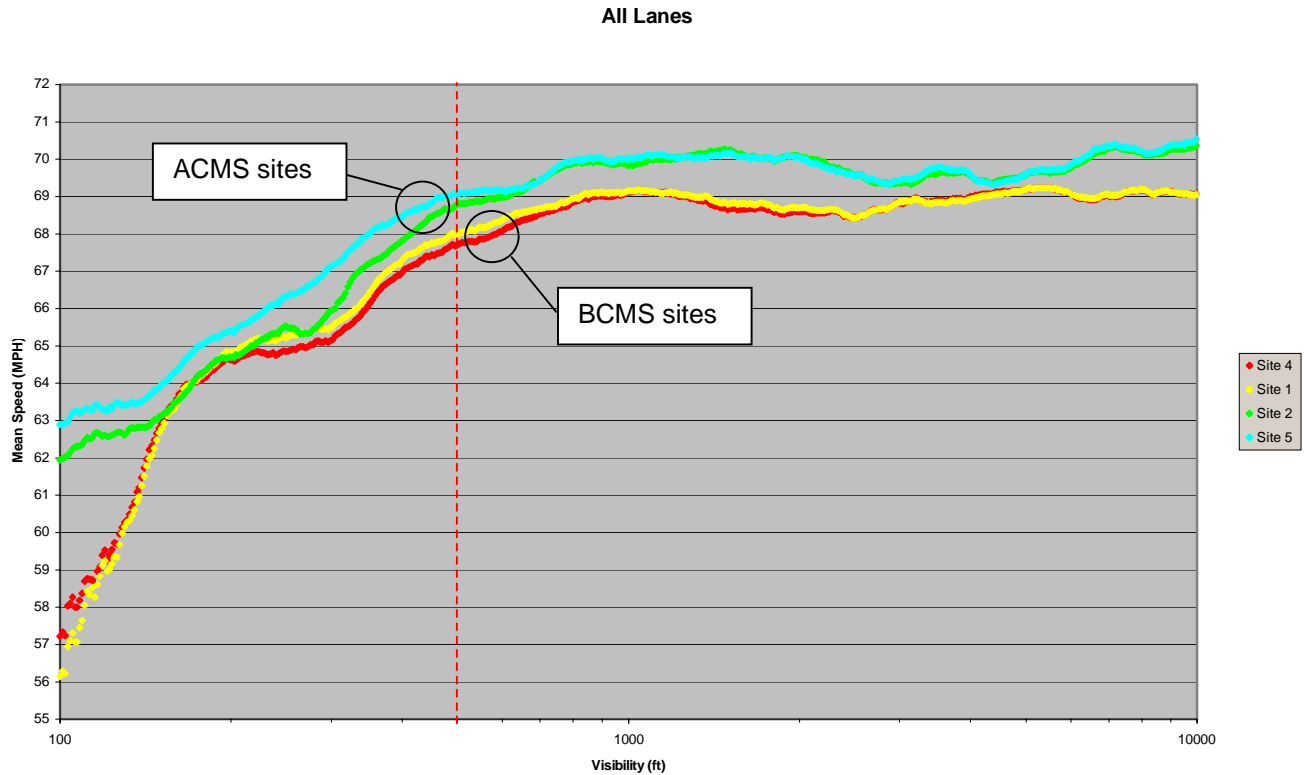

Figure 2.9.1.1. Mean speed as a function of visibility, traffic in all lanes at each site, day and night.

Figure 2.9.1.1 shows that at all sites, over the two-year period of observation, the speeds naturally selected by drivers were not significantly affected by visibility until it falls below approximately 800 feet. The mean speed over this range was between 68.4 and 69.2 before the CMS, and between 69.3 and 70.5 after the CMS. As visibility degraded, drivers reduced their speeds, but the reduction in speed was *greater* before drivers viewed the CMS. The reduction rate with visibility tracks well at all sites until visibility drops below 200 feet. When visibility reached 100 feet, mean speeds BCMS were 56-57 mph, while mean speeds ACMS were 62-63 mph. This trend is counter-intuitive: drivers in very dense fog seemed to slow down less after seeing the CMS message than if they did at the control sites before drivers encountered the CMS.

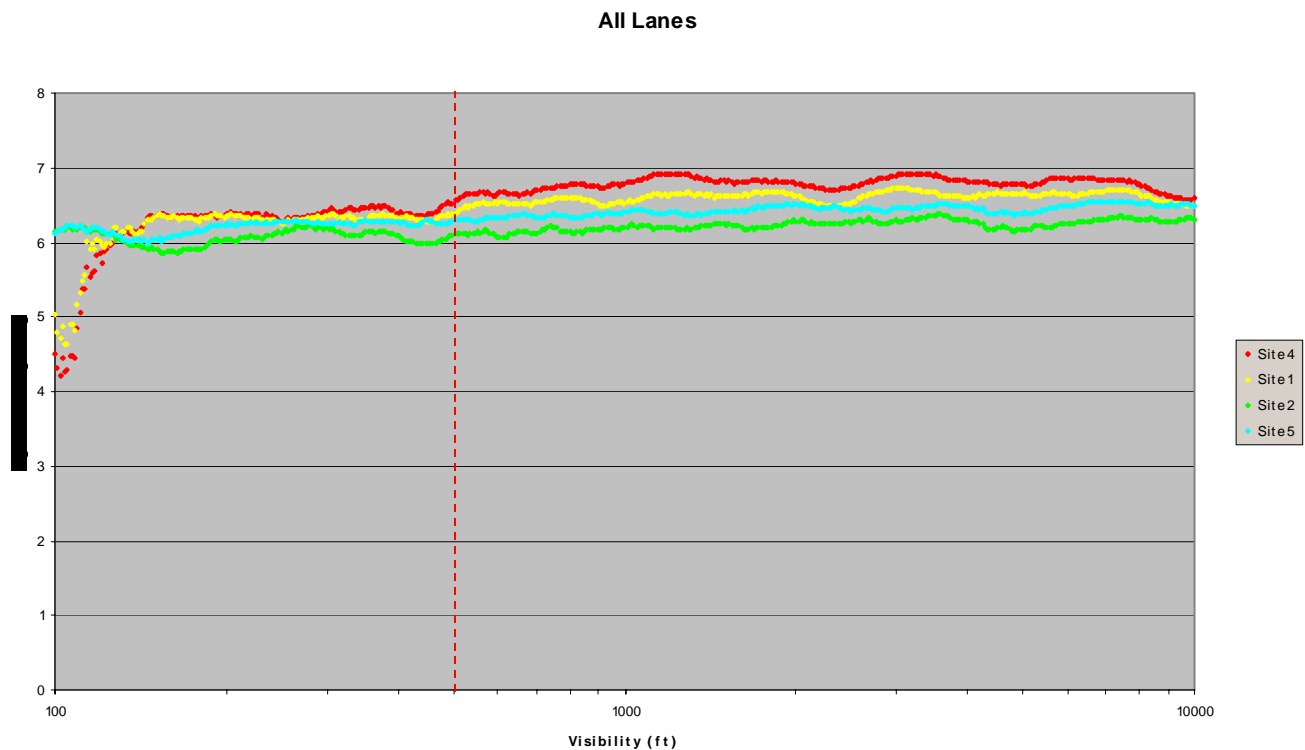

Figure 2.9.1.2. Speed standard deviation as a function of visibility, traffic in all lanes at each site, day and night.

Figure 2.9.1.2 shows the standard deviation of speed in mph. It generally follows the same trend revealed for mean speeds, except that the visibility threshold for departure from the norm was reduced to only approximately 150 feet, even though speeds were falling since the 700 foot visibility threshold. Above 130 feet, speed standard deviation remained between 6 and 7 mph at all sites, although it was approximately 0.5 mph higher before the CMS for visibilities above 500 feet. When visibility dropped below approximately 130 feet (very dense fog) speed standard deviation dropped to between 4 and 5 mph before the CMS, but seemed unaffected after the CMS. Due to the sensitivity of this conclusion of the relative calibrations of the visibility sensors (more on this later), we view this data cautiously. If accurate, it may suggest that drivers naturally tended equalize their speeds a bit more in dense fog, but the task of reading the CMS in dense fog may have caused some slight increase in the spread of speeds, reversing the natural response of the drivers. For reference, Figure 2.9.1.3 is a photograph of the CMS taken in very poor visibility conditions. For a visibility of 100 feet, drivers at 66 mph have theoretically only 1.0 second to read the two-page CMS message.

Figure 2.9.1.4 shows potential collision speed plotted in relationship to visibility. PCS increases as visibility falls, and rates of increase at the BCMS sites and the ACMS sites appear to be equivalent, although PCS is consistently higher ACMS, probably due to the slightly faster normal free speed. There is a bifurcation by as much as 10 mph for visibilities below 500 feet.



Figure 2.9.1.3. Photograph of CMS during very poor visibility. The message displayed on the CMS is “TEST TEST TEST”.

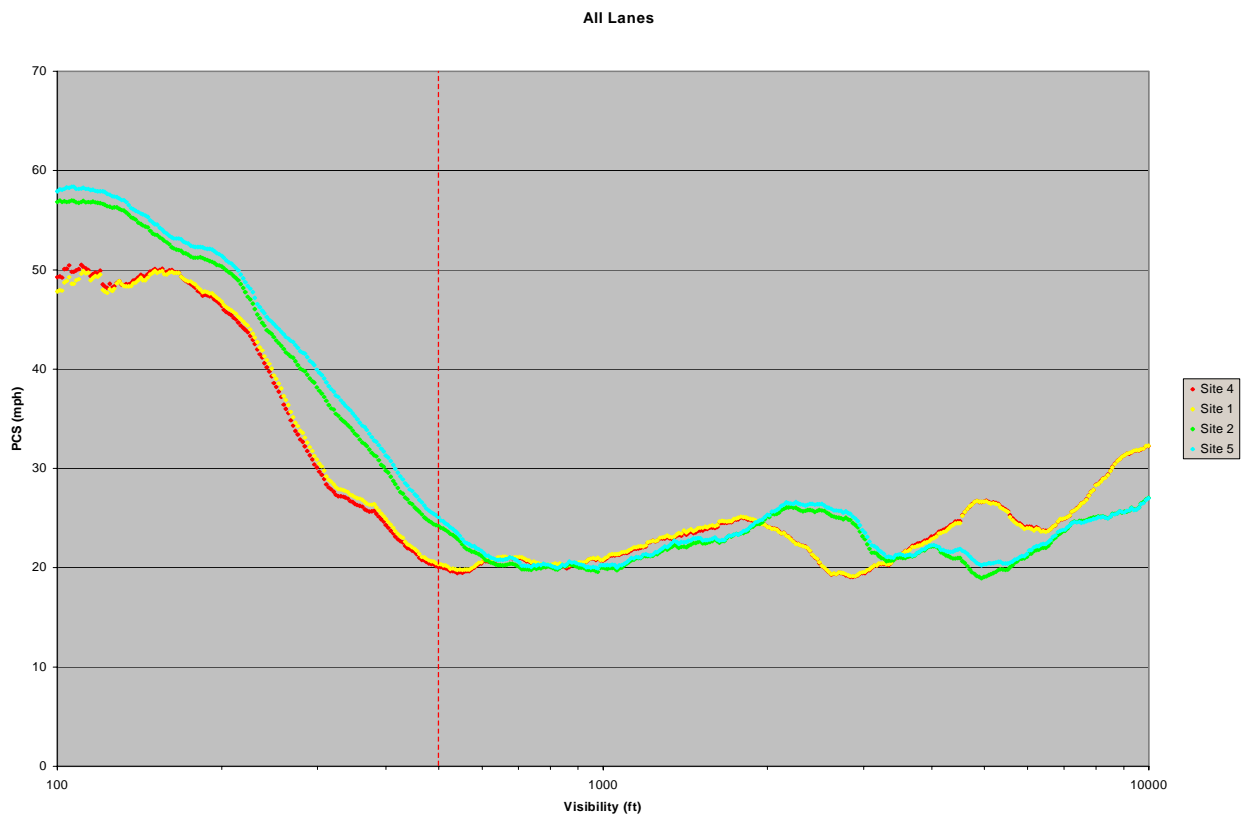

Figure 2.9.1.4. Potential collision speed over all lanes at each site, as a function of visibility.

A note on the ramifications of sensor calibration:

It should be pointed out that the prior three figures are dependent on the calibration of the visibility sensors. For the logarithmic visibility axes, the effect of miscalibration would be a shift to the right or left of all data from either the BCMS sites or from the ACSM sites. This could directly influence the strength of the conclusions drawn from inspection of these figures, although it would not change the general trend. The visibility sensors BCMS and ACMS are identical. The ACMS sensor is actually the visibility sensor for weather station 1. During several periods of up to 2 weeks during the two-year study period, we suspected that one or both sensors had drifted out of calibration. The sensors were aggressively maintained and calibrated by Caltrans District 10 staff on both a routine and asynchronous basis upon our request. We also periodically referenced our evaluation database visibility records during known clear conditions to compare readings. When properly calibrated, the manufacturer guarantees a maximum error of 10% of the reading. The identical dips in the mean speed data of Figure 2.9.2.1 near 110 ft visibility suggests that the ACMS sensor may have been, on average over the two years, 5% higher than the BCMS sensor, which would skew the BCMS data to the left aligning the present 105 ft ACMS with 110 ft BCMS. A 5% left shift of the BCMS data relative to the ACMS data could potentially remove some of the interesting features BCMS at low-visibility (especially standard deviation, see Figure 2.9.1.2), but not eliminate them or change the general observations for any plot.

2.9.2 Day vs. Night

It is useful to re-examine the previously presented data parametric with the day or night condition for two reasons:

- Driver behavior is known to differ between night and day, especially the reaction to uncommon or unexpected stimuli.
- The relationship between the visibility extinction coefficient and the visibility distance changes completely as discussed previously.

We now present the data of the prior three plots again, the first three for daytime, and the next three for nighttime.

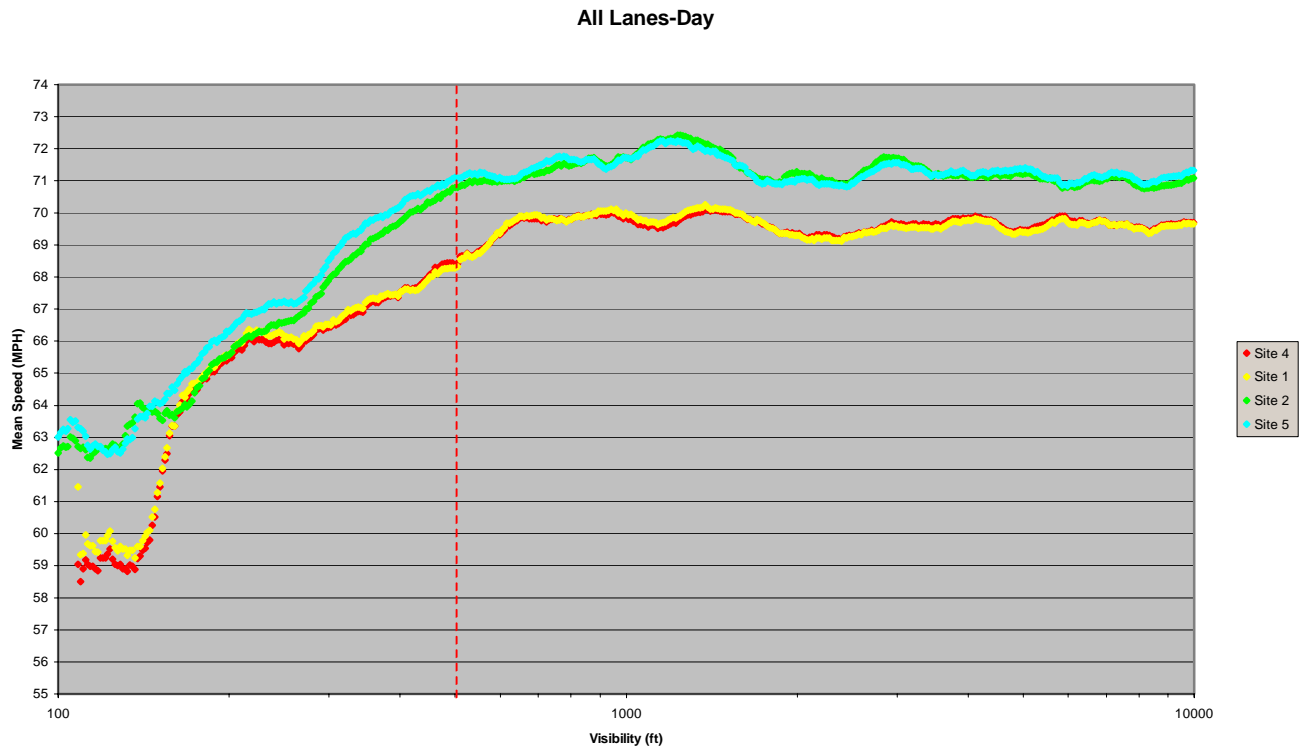

Figure 2.9.2.1. Mean speed as a function of visibility, traffic in all lanes at each site, day.

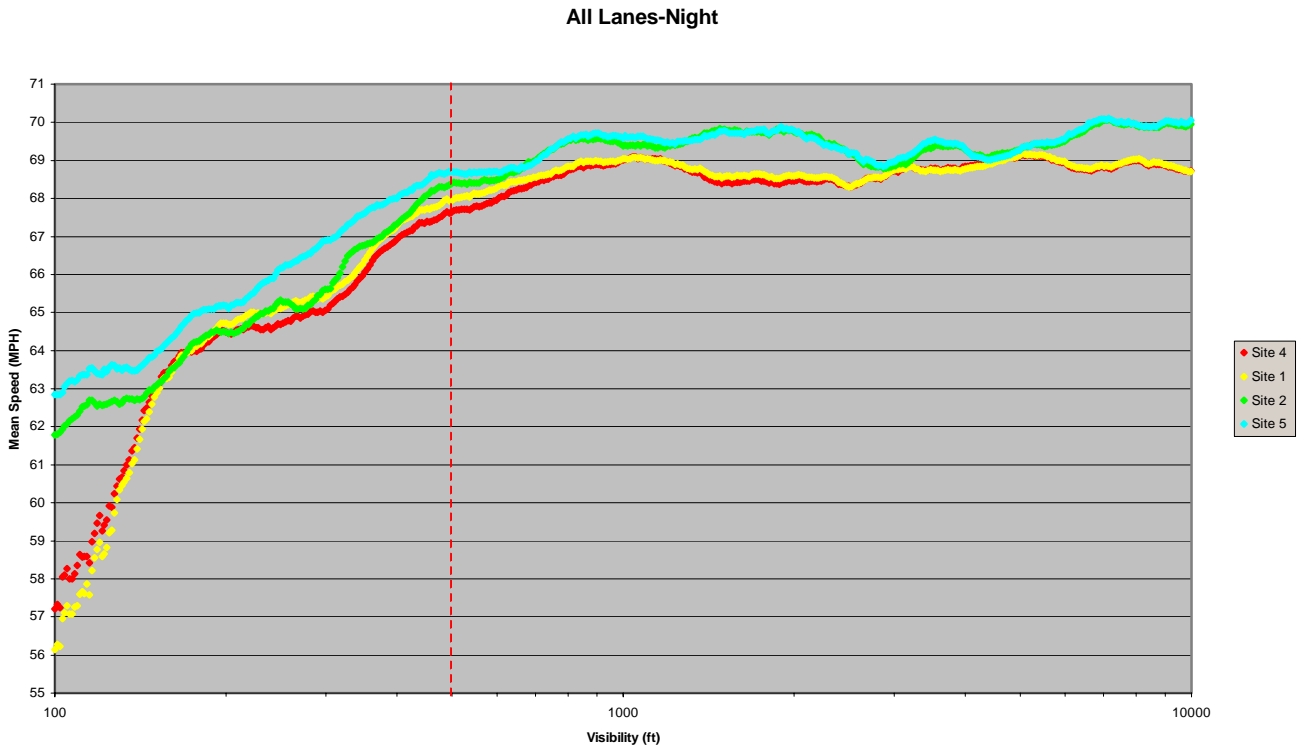

Figure 2.9.2.2. Mean speed as a function of visibility, traffic in all lanes at each site, night.

Mean speeds during clear daytime conditions were higher than nighttime at all sites, and the increase between the ACMS sites over the BCMS sites was slightly higher, but still insignificant (1.0 vs. 0.5 mph). Nighttime drivers naturally start to decrease their speed with reduced visibility at a higher threshold, apparently 1000 feet, compared with 700 feet during the day. The trend remains the same however: at best drivers respond about the same in limited visibility regardless of exposure to the CMS warning speed advisories. At worst, in very dense fog, they actually seem to travel a bit faster at the sites after compared with before the CMS.

An interesting reversal of the 24-hour observation is seen for speed standard deviation at low visibilities. Speed standard deviation BCMS increased slightly, while ACMS it decreased slightly, although the difference was between the two was only approximately 1.0 mph. This is seen in Figure 2.9.2.3.

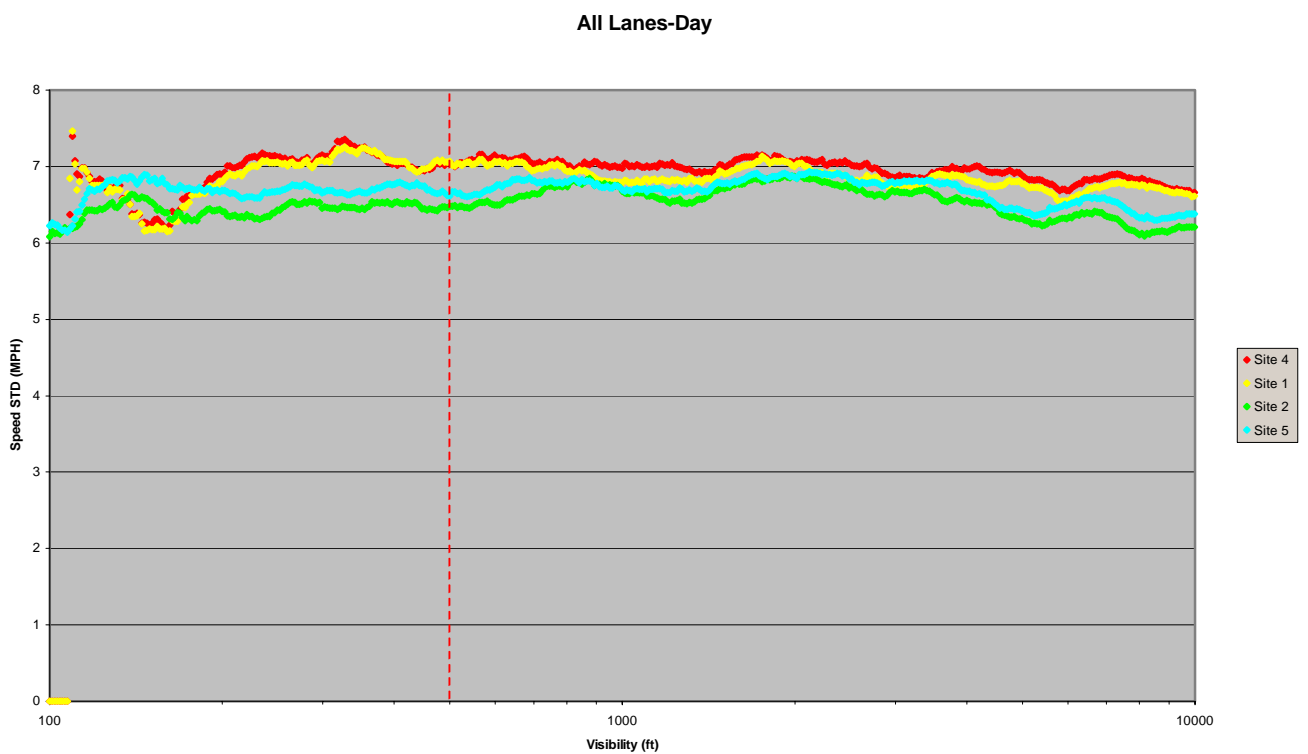

Figure 2.9.2.3. Speed standard deviation as a function of visibility, traffic in all lanes at each site, day.

Exactly the opposite trend at low visibilities was observed at night, as can be seen in Figure 2.9.2.4. Standard deviation BCMS dropped to 5-6 mph, while ACMS it remained at the clear-visibility norm of 6 mph, despite the reduction in mean speed in this dense fog condition.

It may be generally observed, however, that over all most the entire visibility range, day and night, speed standard deviation remained almost invariant, and since it did not change significantly ACMS for visibilities below 500 ft., it did not appear to be affected by the CMS message.

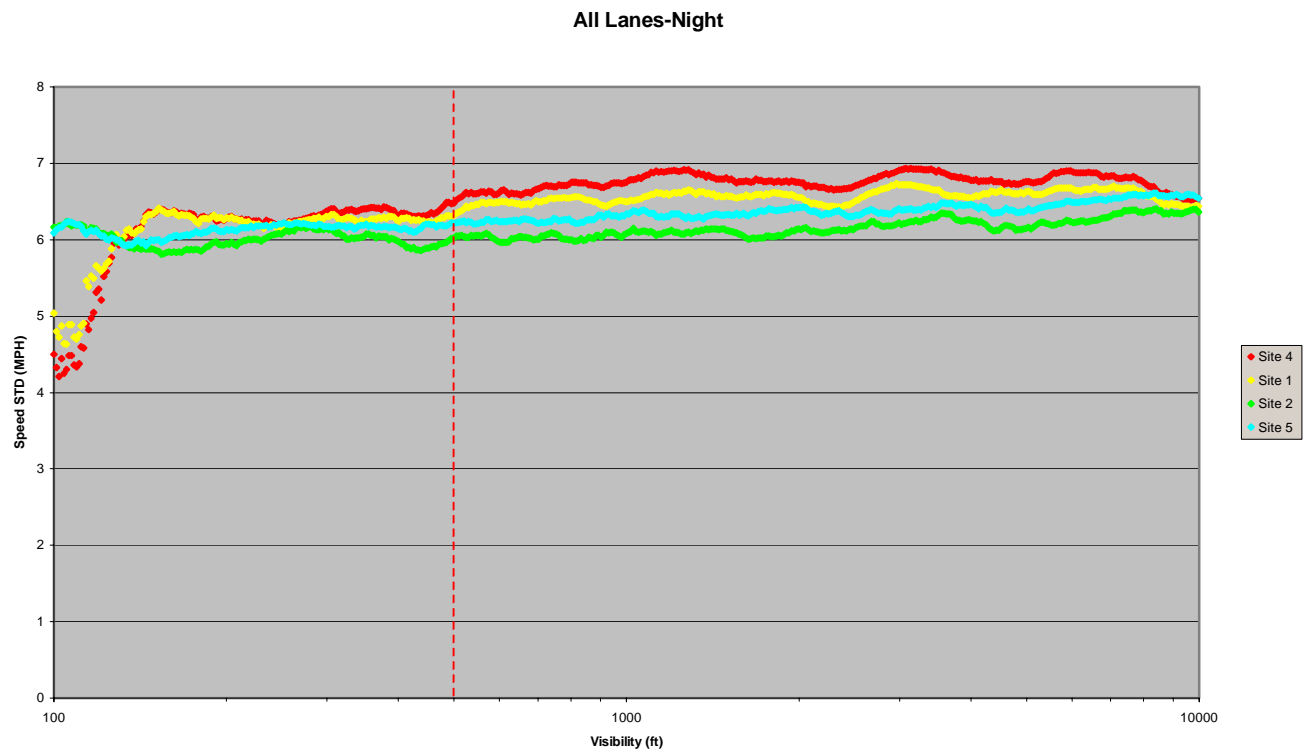

Figure 2.9.2.4. Speed standard deviation as a function of visibility, traffic in all lanes at each site, night.

PCS plotted as a function of visibility, day and night, are compared in Figure 2.9.2.5 and Figure 2.9.2.6, below. Noteworthy in these plots are:

- Mean PCS during the day for visibility above 500 feet is about twice the level at night. This clearly indicates that drivers are more cautious at night, allowing greater separation distances, even if the day/night mean speed differences (Figure 2.9.2.1 and Figure 2.9.2.2) are small.
- During the day, the relationship between PCS and visibility is almost identical ACMS and BCMS, including fog conditions during which drivers ACMS were exposed to the CMS. The average trend is the same at night until visibility falls below 500 feet. PCS increases more ACMS than BCMS contraindicating a safety enhancing effect of the CMS message.
- When visibility falls to 100 feet, PCS day and night both increase to the same range of 50-60 mph, with PCS worse ACMS than BCMS despite the CMS message. The mean traffic speed is 62-63 mph ACMS (see Figure 2.9.2.2) under these very poor visibility conditions. The near equality of PCS with the mean speed implies that any traffic disturbance sufficient to cause aggressive but otherwise normal braking would almost certainly result in a multi-car collision, as every vehicle behind would be unable to avoid a rear-end collision. This is true during both day and night conditions.

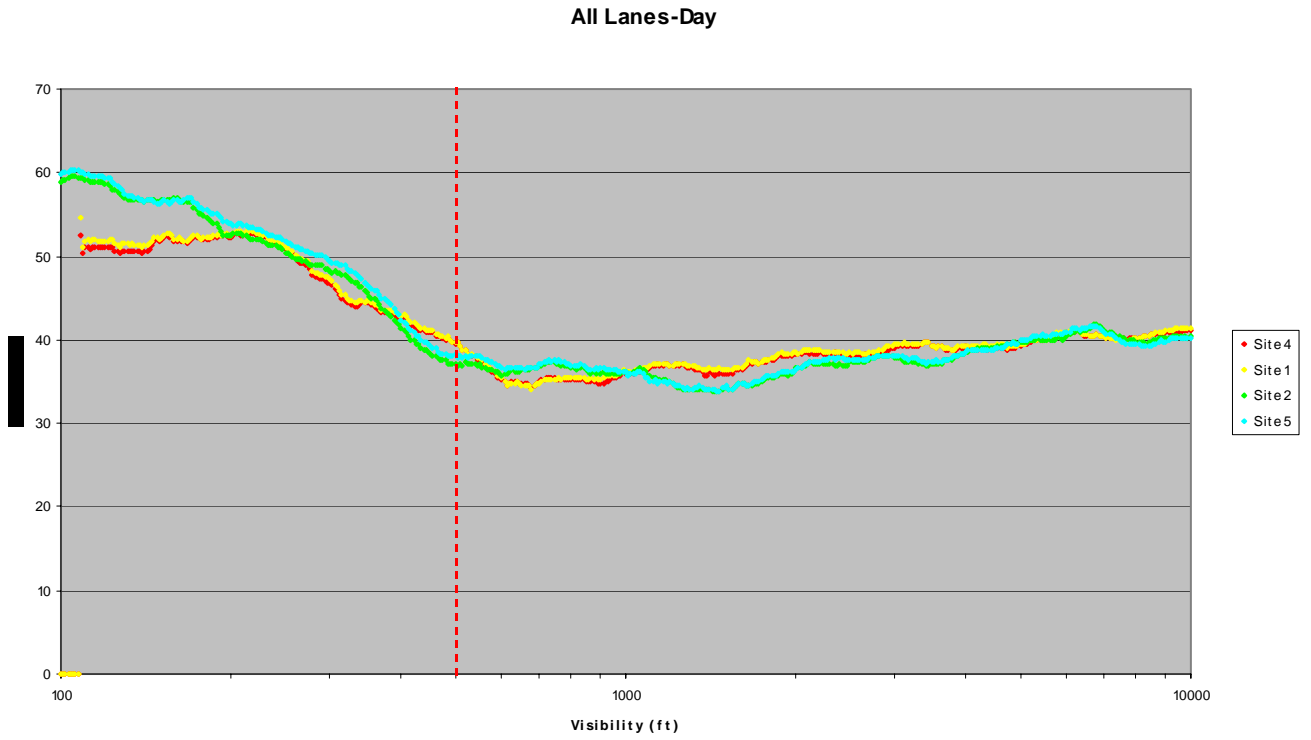

Figure 2.9.2.5. PCS as a function of visibility, all lanes, day.

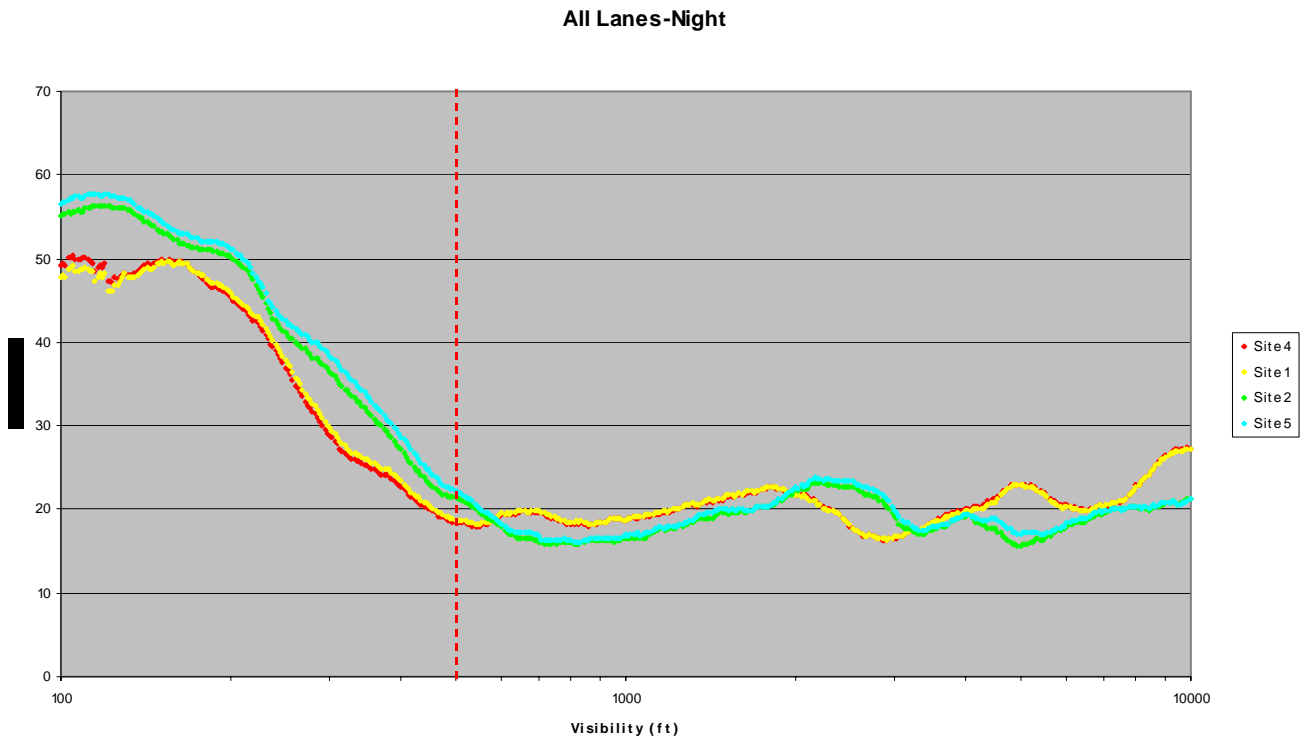

Figure 2.9.2.6. PCS as a function of visibility, all lanes, night.

2.9.3 Lane-specific

The following figures present the same information as just presented, but break out individual results per lane. This breakdown helps to reveal lane, and therefore vehicle-class specific behavior, and amplifies somewhat the safety-relevance of speed standard deviation, since it considers only vehicles in the same lane within the 45 second moving window of observation for this metric.

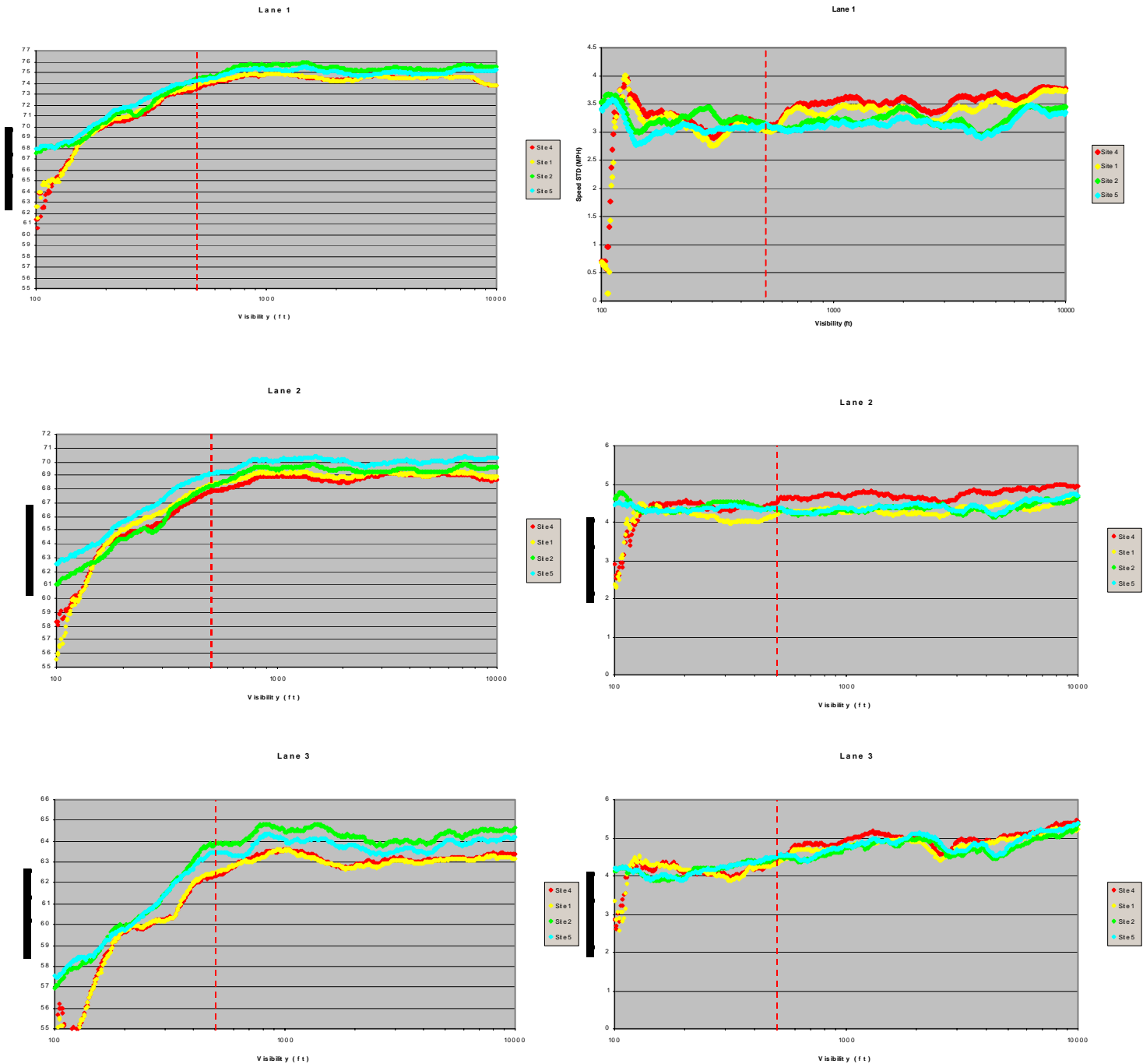

Figure 2.9.3.1. Mean speed (left) and speed standard deviation (right) for lane 1 (top) lane 2 (middle) and lane 3 (bottom) as a function of visibility, day and night.

Mean speeds are, as expected, highest in lane 1 at all sites (75-76 mph), and the speed reduction in dense fog is the least. For all lanes, both mean speed and speed standard deviation reduce much more BCMS than ACMS as visibility approaches 100 feet, but this trend is not observed for visibilities over 200 feet. Speed standard deviation in lane 1 is consistently the lowest (3-3.5 mph), at all sites. Note the expanded scale for standard deviation for lane 1. The mean speed scale is expanded for the lane 3 data; average speed ACMS vs. BCMS is approximately 1 mph greater ACMS vs. BCMS in all lanes under clear conditions. The spread becomes slightly greater in lane 3 under poor visibility conditions. Speed standard deviation in lane three decreases by about 1 mph at all sites as visibility becomes poor, with no observable differences in magnitudes or trends between ACMS and BCMS sites. For both metrics, somewhat different trends with respect to visibility are observed in each lane, but these trends are very similar BCMS and ACMS. Conclusions from lane-specific observations of PCS were similar. These graphs are available in the appendix.

On the basis of this lane-specific comparison, it does not appear that the CMS message is affecting an incremental reduction in either mean speed or speed standard deviation in reduced visibility in any lane.

2.9.4 Segregated by vehicle class

One final question is worth investigating, in the interest of identifying the classes of vehicles than might most benefit from improvements in driving behavior or road safety interventions. We now examine the behavior of drivers as a function of visibility subdivided into three broad vehicle classes. As expected, results are similar to those of the previous subsection, in which data were segregated by lane, since most large trucks are found in lane 3. Similarly, lane 1 is populated almost exclusively by Class 1-4 vehicles. Lane 2 might best be characterized in terms of the preferred speed of the drivers, however, and not indicative of a predominant vehicle class.

Our instrumentation at four traffic monitoring sites recorded the inductive length for each vehicle. Inductive length is not considered an accurate measure of the true vehicle length, but it is commonly used in traffic surveys as a surrogate for vehicle classes. This is neither precise (since inductive length is not true length) nor in any way general (since length does not necessarily imply a vehicle classification). The FHWA defines 13 vehicle classes, ranging from small 2-axle automobiles and light trucks in classes 1-4, to heavy-duty vehicles with 7 axles in Class 13¹. We assume:

Vehicles 20 feet or less in inductive length are classes 1 through 4 (cars and light trucks)

Vehicles over 20 feet but less than 45 feet in inductive length are classes 5 and 6 (mid-range trucks)

¹ US Department of Transportation, Federal Highway Administration. Traffic Monitoring Guide, Section 4 "Vehicle Classification Monitoring," available online <http://www.fhwa.dot.gov/ohim/tmg4.htm#Summary%20Vehicle%20Classification%20Statistics>

Vehicles over 45 feet in length are classes 7 and 8 and larger (heavy duty multi-axle, possibly multi-carriage truck)

As before, the following tables cover the two-year period of study, for both day and night conditions.

Figure 2.9.4.1, Figure 2.9.4.2 and Figure 2.9.4.3 show respectively, mean speed, speed standard deviation, and potential collision speed subdivided by the approximate vehicle length class.

Table 2.2.1.1 is repeated below for convenience of identifying sites by color code on the plots.

Direction of traffic flow	Site No.	Color of plot line	Description	Site name	Distance from prior site
	4	Red	First BCMS site	Downing Road	N/A
	1	Yellow	Second BCMS site	French Camp Slough	0.1
	3		CMS site	CMS	1.2
	2	Green	First ACMS site	Mathews Road	0.5
	5	Blue	Second ACMS site	El Dorado Overcrossing	0.6

The most noteworthy observations from these figures are:

- Class 1-4 vehicles drive approximately 70 mph BCMS and 72 mph ACMS under clear weather conditions. This difference in speeds is not seen for class 5-6 vehicles, which drive approximately 62 mph at all sites, or for class 7+ vehicles that drive approximately 59 mph at both BCMS and ACMS sites. Whatever structural conditions encourage small vehicles to drive 2 mph faster at the ACMS sites does not affect larger vehicles.
- There is also greater consistency BCMS and ACMS in the response of the larger vehicles as visibility decreases. When visibility is 100 feet, class 7+ vehicles drive 55 mph with less than 1 mph difference between sites. Class 5-6 vehicles slow down approximately 2 mph more BCMS compared with ACMS. Class 1-4 vehicles slow down 5 mph more BCMS (58 mph) compared with ACMS (63 mph) sites (despite being advise to reduce speed to 30 mph).
- Speed standard deviation was considerably higher among Class 1-4 vehicles, averaging 5.5 (ACMS) to 6.0 (BCMS) mph in clear weather (not affected by a message). Class 5-6 vehicle averaged 2.9 mph ACMS and 3.1 mph BCMS. Speed standard deviation for Class 7+ vehicles differed approximately 0.3 mph during clear conditions down to 250 feet visibility, and this difference reduced approximately zero for visibility between 150 and 250 feet. At 100 feet visibility, speed standard deviation dropped by 2.0 mph BCMS, but did not change ACMS for Class 1-4 vehicles. For Class 5-6 vehicles, neither site experienced any significant change at extremely poor visibility. For Class 7+ vehicles, speed standard deviation increased by approximately 1.0 mph in extremely poor visibility compared with clear conditions, with both sites responding similarly, although the BCMS sites were 0.34 mph higher at 100 feet visibility.

- Potential collision speed may contain some interesting inferences about average levels of driver risk in each vehicle class. Class 1-4 drivers averaged 20 to 30 mph PCS at both sites in clear conditions, increasing in fog to 50 mph BCMS and 60 mph ACMS. However, Class 5-6 and 7+ drivers maintained average PCS levels near zero mph under clear conditions, increasing to 45 mph BCMS and 50 mph ACMS when visibility degraded to 100 feet. The radically difference PCS levels in clear conditions imply that truck drivers maintain constantly safer following distances, and this trend but diminishes somewhat in poor visibility.
- Focusing on the 100-500 ft visibility range ACMS, compared with visibilities above 500 feet, and comparing trends against those BCMS, no improvement is seen in any of the metrics. Mean speed for all vehicle classes dropped less ACMS than it did BCMS in fog. For Class 1-4 vehicles, speed standard deviation reduced BCMS under very poor visibility, while there was no significant change ACMS. For other vehicle classes, there was no significant difference in the Spd STD trend AMCS compared with BCMS. PCS consistently increased ACMS 7-10 mph more than it increased BCMS in poor visibility. Since PCS levels in all classes were approximately equal at both sites in clear visibility, these observations cannot be attributed to structural differences between the ACMS and BCMS sites. Collectively, these observations suggest a neutral to negative safety influence of the CMS message for all vehicle classes, with Class 1-4 vehicles affected slightly more than Classes 5 and larger.

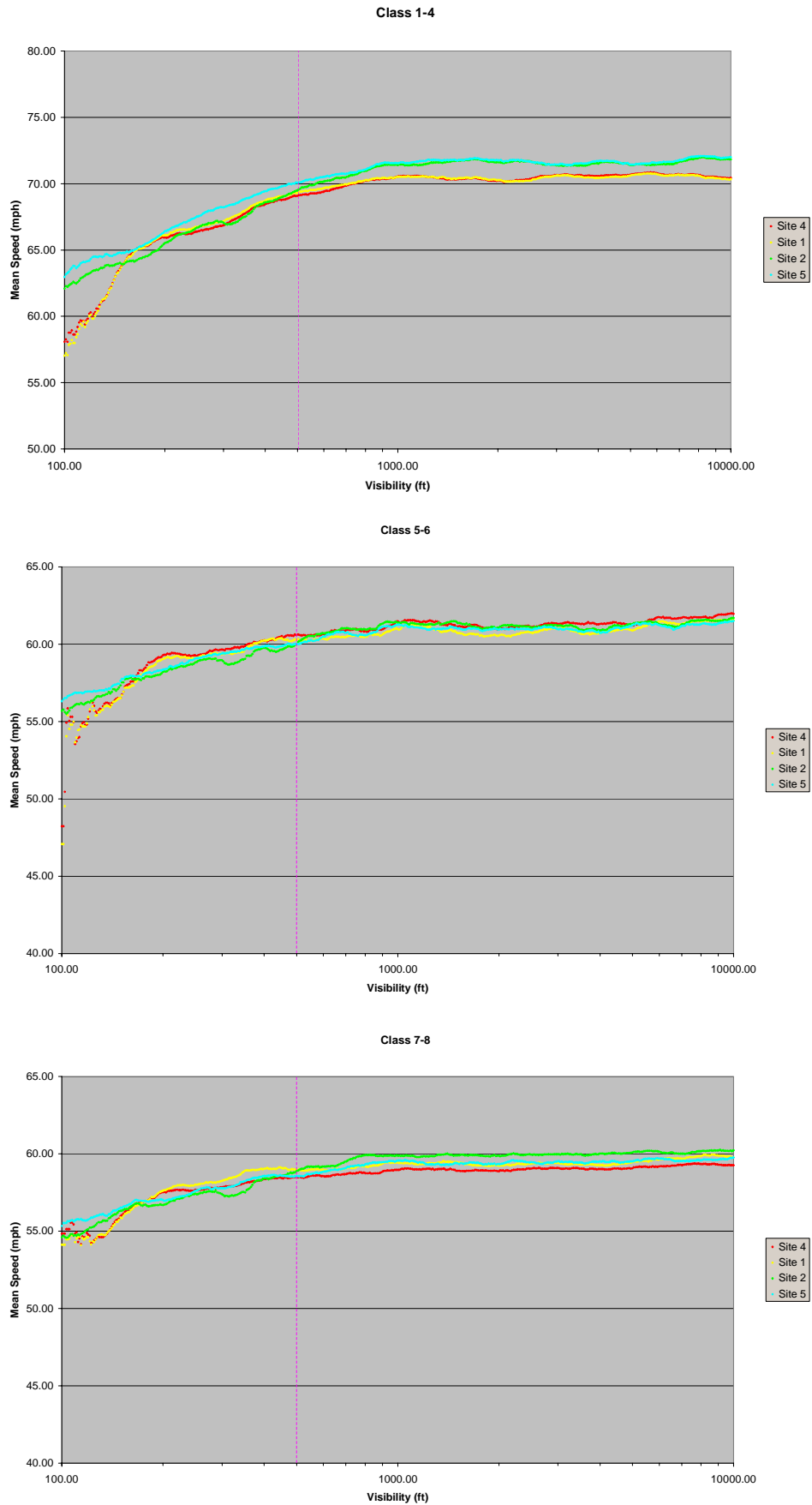

Figure 2.9.4.1. Mean speed (mph) by approximate vehicle length class.

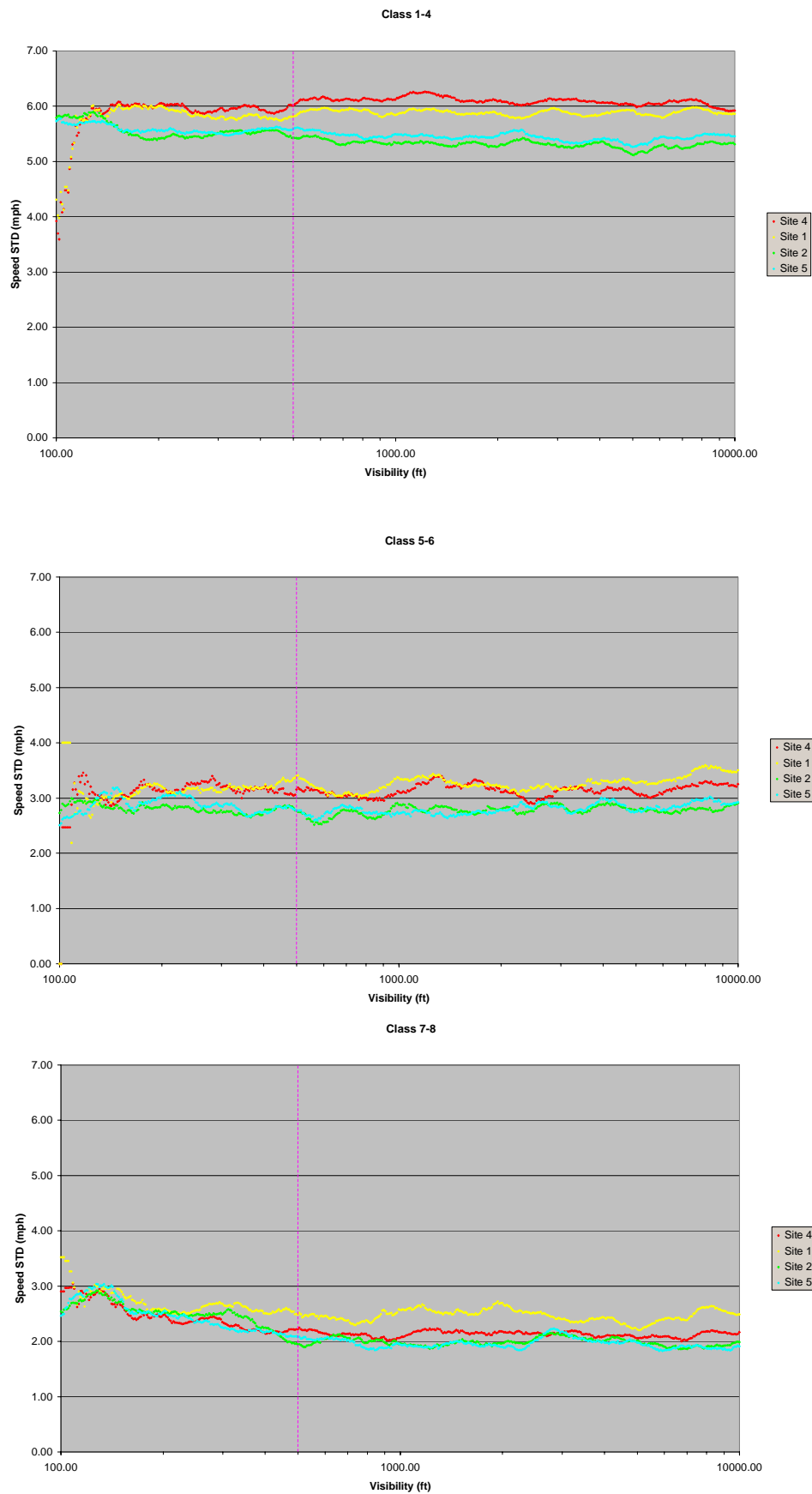

Figure 2.9.4.2. Standard deviation of speed (mph) by approximate vehicle length class.

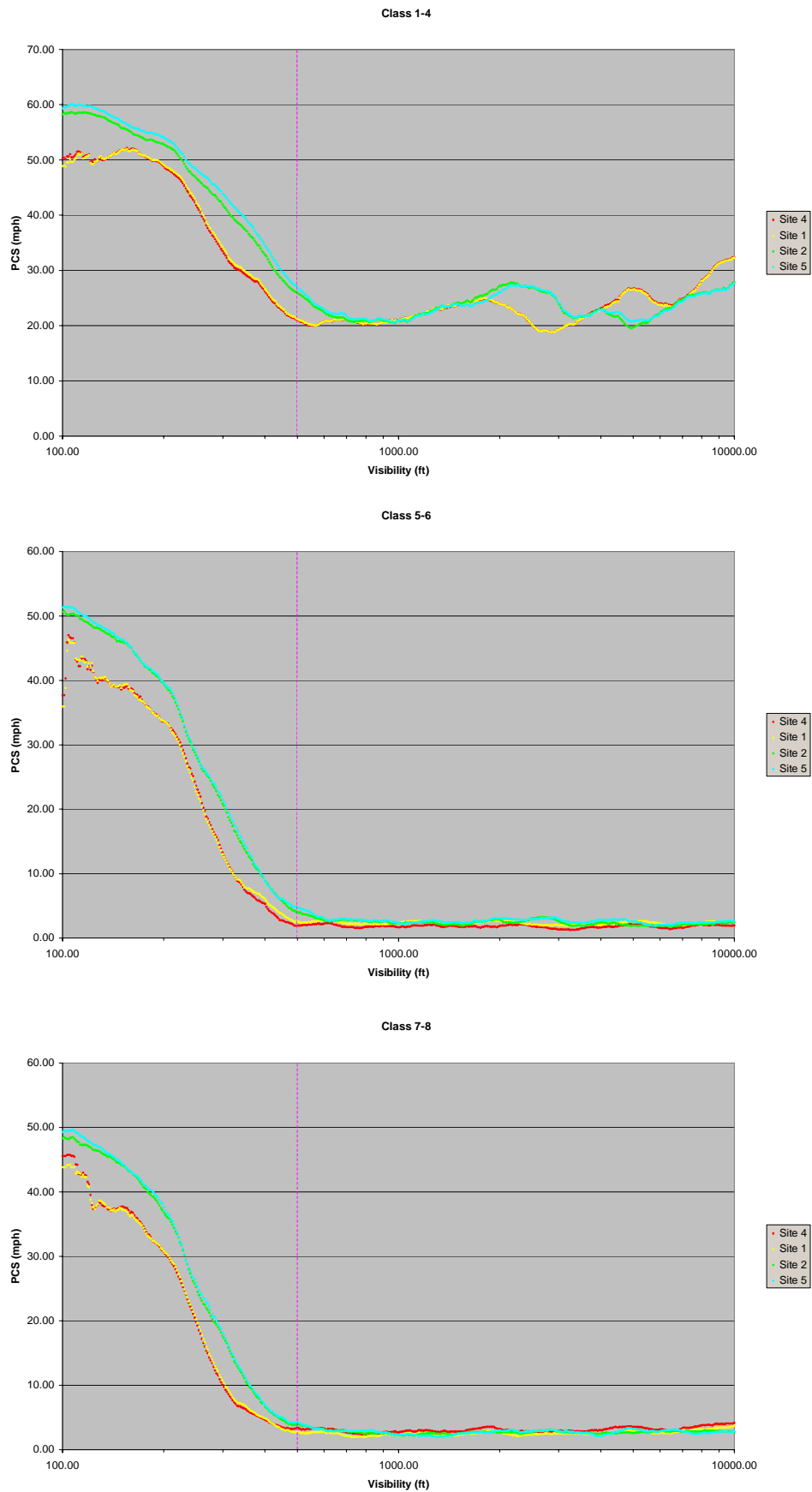

Figure 2.9.4.3. Potential collision speed (mph) by approximate vehicle length class.

2.9.5 Statistics over all message periods

We now examine cumulative statistics acquired over all events in which CMS 1 automatically activated with a fog warning message over the two-year period study. We examine each year separately, since in the first year two levels of warning messages were displayed (45 and 30 mph), while in the second year, only one (45 mph) was displayed for all fog visibilities less than 500 feet. In the tables that follow:

Message Type is the message displayed (30 mph, 45 mph or blank).

Count is the total number of individual times this message was displayed.

Total Duration is the total time in seconds that this message was displayed.

Mean Spd is the difference between the mean speed after the CMS and before the CMS, measured over the duration of the display period (mph).

Spd STD is the difference between the speed standard deviation after the CMS and before the CMS, measured over the duration of the display period (mph).

PCS is the difference between the mean PCS after the CMS and before the CMS, measured over the duration of the display period.

Event Average is the average of the numbers generated for each instance that the message was displayed, one value per display period.

Time-Weighted is the time-cumulative average or standard deviation of value measured over vehicles in all periods that the message was displayed.

% Events Values Decreased is the percentage of the display periods in which the value of the metric measured after the CMS was less than the value before the CMS. For all metrics, this would suggest that traffic was safer after the CMS compared with before.

In the first fog season (2003-04):

Table 2.9.5.1. Cumulative results for periods in which each message type was displayed, all differential visibility conditions, 2003-04.

Event Type	Count	Tot Dur	Event Avg			Time Weighted Average			% Events Values Decreased		
			Mean Spd	Spd STD	PCS	Mean Spd	Spd STD	PCS	Mean Spd	Spd STD	PCS
Fog 45 MPH	86	106006	-0.78	-0.07	9.78	-0.60	-0.09	10.17	61.63%	53.49%	16.28%
Fog 30 MPH	47	63203	-1.62	0.35	23.60	-1.35	0.08	20.95	76.60%	48.94%	4.26%
Blank, Vis < 100ft	9	9329	-1.16	-1.06	25.15	-1.84	-0.41	24.32	77.78%	88.89%	0.00%
Blank	68	314674	1.24	-0.23	0.47	1.42	-0.13	0.36	11.76%	76.47%	51.47%

Referring to Table 2.9.5.1, the ADVISE 45 MPH message was displayed a total of 86 times over a total duration of 106006 seconds. Mean speed decreased an average of 0.78 mph ACMS compared with BCMS, when each event is equally weighted, or an average of (0.60) mph when the display periods were treated cumulatively. However, the normal trend, revealed when the message is blank, is a 1.24 (1.42) mph increase in traffic speed ACMS compared with BCMS. Mean speed decreased ACMS 61.63% of the times that the message was displayed. This is an indication that the display of this message affected a reduction of 2.0 mph relative to the natural tendency of the drivers to speed up at the ACMS sites (drivers didn't speed up as much).

Speed standard deviation (Spd STD) decreased an average of 0.07 (0.09) mph ACMS compared with BCMS. But when no message was displayed, drivers naturally reduced this metric by 0.23 (0.13) mph. If these small differences were significant, they would indicate that speed variance naturally reduced ACMS more than with the added influence of this message. The fact that Spd STD decreased only 53.5% of the time confirms the nearly neutral relationship.

PCS increased by 9.78 (10.17) mph during the display of this message, compared with 0.47 (0.36) mph when no message was displayed, a net gain of 9.3 (9.8) mph possibly attributable to the CMS messages. PCS decreased only 16.28 % of the times this message was displayed, which means that it usually increased. PCS increased much more than mean speed decreased, relative to the natural response of drivers. Considering both, it appears that the inferred positive safety effect this message may have had on mean speed was possibly offset by a negative effect on PCS.

Similar observations can be made for the 47 times and 63203 seconds that the 30 mph advisory message was displayed, affecting a somewhat greater 2.9 (2.8) mph mean speed reduction relative to the blank message response, but a dramatically greater 23.1 (20.6) mph increase in PCS.

The case of a blank message when visibility dropped below 100 feet is treated separately from a blank message due to good visibility, since the trigger conditions are the extreme opposites. For the nine cases in which this occurred, driver reduced their speed more than when the 45 mph message was displayed, but less than when the 30 mph message was displayed. PCS was slightly higher than either. This observation confirms that drivers were responding primarily to the visibility itself, but allows that the presence of a message may have supplemented their response.

When the correct blank message was displayed, differences in all metrics before and after the CMS were negligible, and the effects reasonably balanced, verifying that baseline conditions were nearly equivalent before and after the CMS.

During most periods, visibility BCMS and ACMS were significantly different, most often with visibility worse ACMS since this site controlled the CMS. Table 2.9.5.2, Table 2.9.5.3 and Table 2.9.5.4 are presented in recognition of the major difference in data between these two situations. We note that the magnitude of the difference in visibility between the BCMS and ACMS sites is not revealed in these

classifications; only the net direction of the change. Therefore, the magnitude of the difference in table values is not nearly as important as the sign of the differences.

As before, for the 2003-04 fog season, for the message display periods during which visibility **was worse** after the CMS compared with before the CMS:

Table 2.9.5.2. Cumulative results for periods in which each message type was displayed, visibility worse ACMS, 2003-04.

Event Type	Count	Tot Dur	Event Avg			Time Weighted Average			% Events Values Decreased		
			Mean Spd	Spd STD	PCS	Mean Spd	Spd STD	PCS	Mean Spd	Spd STD	PCS
Fog 45 MPH	81	100290	-1.00	-0.08	10.53	-0.76	-0.11	11.07	64.20%	53.09%	12.35%
Fog 30 MPH	44	61047	-1.80	0.35	24.37	-1.42	0.09	21.41	79.55%	50.00%	2.27%
Blank, Vis < 100ft	9	9329	-1.16	-1.06	25.15	-1.84	-0.41	24.32	77.78%	88.89%	0.00%
Blank	57	239242	1.14	-0.28	0.68	1.34	-0.19	0.63	14.04%	80.70%	47.37%

In all categories, the results have improved compared with the set of all cases that year. Mean speed is reduced ACMS 2.14 (2.10) mph more than the blank message case, 64.2% of the time when the 45 mph advisory message is displayed. Standard deviation differences are neutral when the message is displayed, increasing and decreasing almost an equal number of periods. But the same trend, equally as significant, is seen when the blank message is displayed while visibility is below 100 ft.

For the message display periods during which visibility **was better** after the CMS compared with before the CMS:

Table 2.9.5.3. Cumulative results for periods in which each message type was displayed, visibility worse BCMS, 2003-04.

Event Type	Count	Tot Dur	Event Avg			Time Weighted Average			% Events Values Decreased		
			Mean Spd	Spd STD	PCS	Mean Spd	Spd STD	PCS	Mean Spd	Spd STD	PCS
Fog 45 MPH	3	3210	2.89	-0.15	-2.67	2.78	0.30	-7.95	33.33%	66.67%	66.67%
Fog 30 MPH	1	717	1.69	-0.93	9.19	1.69	-0.93	9.19	0.00%	100.00%	0.00%
Blank, Vis < 100ft	N/A	N/A	N/A	N/A	N/A	N/A	N/A	N/A	N/A	N/A	N/A
Blank	7	46632	1.73	-0.01	-1.52	1.63	0.00	-1.36	0.00%	57.14%	100.00%

Periods are far fewer, as explained above. The opposite trend is observed compared with the prior cases in which visibility was better BCMS. During the three times that ADVISE 45 was displayed, mean speed ACMS *increased* an average of 1.16 (1.15) mph more than the blank message case. PCS decreased 1.15 (6.59) mph. Since the ADVISE 30 message only occurred once when visibility was worse BCMS, it is not considered. There were no situations in which the CMS was blank due to visibility ACMS below 100 feet.

Only in a few cases were visibility conditions nearly identical (+/-10%) for the majority of a message display period. Those cases are summarized below:

Table 2.9.5.4. Cumulative results for periods in which each message type was displayed, visibility equal BCMS and ACMS, 2003-04.

Event Type	Count	Tot Dur	Event Avg			Time Weighted Average			% Events Values Decreased		
			Mean Spd	Spd STD	PCS	Mean Spd	Spd STD	PCS	Mean Spd	Spd STD	PCS
Fog 45 MPH	2	2506	2.36	0.48	-1.67	1.61	-0.01	-2.62	0.00%	50.00%	100.00%
Fog 30 MPH	2	1439	0.69	1.03	14.06	0.16	0.52	6.94	50.00%	0.00%	50.00%
Blank, Vis < 100ft	N/A	N/A	N/A	N/A	N/A	N/A	N/A	N/A	N/A	N/A	N/A
Blank	4	28800	1.79	0.11	0.91	1.79	0.11	0.91	0.00%	50.00%	25.00%

Mean speed increased an average of +0.57 (-0.18) mph and PCS decreased 2.58 (3.53) during the two cases in which the ADVISE 45 message was displayed compared with the blank message cases. The opposite average trend occurred during the two cases in which the ADVISE 30 MPH message was displayed; mean speed decreased 1.1 (1.63) mph and PCS increased 13.15 (6.03) mph compared with the blank message cases. Standard deviation generally increased, but significantly.

Table 2.9.5.2 confirms that drivers naturally slowed down when driving into denser fog as they traveled from BCMS to ACMS, and that this natural tendency dominates the perceived results over all conditions in Table 2.9.5.1. Table 2.9.5.3 shows that when visibility improved ACMS compared to BCMS, drivers increased their speed despite the speed advisory messages. In the special cases (Table 2.9.5.4) that visibility was approximately equal before and after the CMS and was therefore not a factor, results were mixed suggesting a neutral influence.

For the 2004-05 fog season:

We now repeat the previous four tables for the second year of the study, 2004-05. During this period, the CMS displayed only one type of message: DENSE FOG AHEAD, ADVISE 45 whenever visibility was below 500 ft AND relative humidity was greater than 75%. Unlike the prior year, this included the under-100 ft. visibility condition.

For all differential visibility conditions:

Table 2.9.5.5. Cumulative results for periods in which each message type was displayed, all differential visibility conditions, 2004-05.

Event Type	Count	Tot Dur	Event Avg			Time Weighted Average			% Events Values Decreased		
			Mean Spd	Spd STD	PCS	Mean Spd	Spd STD	PCS	Mean Spd	Spd STD	PCS
Fog 45 MPH	199	467708	-0.74	-0.36	7.18	-0.78	-0.19	7.13	63.32%	77.89%	18.09%
Blank	166	663515	0.91	-0.36	0.57	1.06	-0.38	0.01	12.65%	82.53%	39.76%

When visibility was worse after the CMS than before the CMS:

Table 2.9.5.6. Cumulative results for periods in which each message type was displayed, visibility worse ACMS, 2004-05.

Event Type	Count	Tot Dur	Event Avg			Time Weighted Average			% Events Values Decreased		
			Mean Spd	Spd STD	PCS	Mean Spd	Spd STD	PCS	Mean Spd	Spd STD	PCS
Fog 45 MPH	173	413566	-0.98	-0.38	8.29	-0.89	-0.20	8.08	66.47%	79.77%	13.29%
Blank	110	413956	0.66	-0.35	1.53	0.86	-0.37	0.59	17.27%	80.91%	34.55%

When visibility was worse before the CMS than after it:

Table 2.9.5.7. Cumulative results for periods in which each message type was displayed, visibility worse BCMS, 2004-05.

Event Type	Count	Tot Dur	Event Avg			Time Weighted Average			% Events Values Decreased		
			Mean Spd	Spd STD	PCS	Mean Spd	Spd STD	PCS	Mean Spd	Spd STD	PCS
Fog 45 MPH	17	14961	1.44	-0.17	-1.23	1.35	-0.13	-3.46	35.29%	70.59%	47.06%
Blank	33	158366	1.79	-0.38	-2.64	1.62	-0.34	-1.83	0.00%	90.91%	63.64%

And when visibility was nearly equal before and after the CMS:

Table 2.9.5.8. Cumulative results for periods in which each message type was displayed, visibility equal BCMS and ACMS, 2004-05.

Event Type	Count	Tot Dur	Event Avg			Time Weighted Average			% Events Values Decreased		
			Mean Spd	Spd STD	PCS	Mean Spd	Spd STD	PCS	Mean Spd	Spd STD	PCS
Fog 45 MPH	9	39181	-0.15	-0.34	1.62	-0.50	-0.04	1.13	55.56%	55.56%	55.56%
Blank	23	91193	0.85	-0.34	0.60	0.97	-0.53	0.56	8.70%	78.26%	30.43%

The overall effect on mean speed during the display of ADVISE 45 was a 1.64 (1.84) mph reduction in mean speed and 6.61 (7.12) mph increase in PCS beyond the response to the blank messages. Mean speed decreased in 63.21% of the cases, and PCS increased in 18.09% of the cases.

Jumping to Table 2.9.5.8, the nine cases in which visibility was equal at both sites during the display of the ADVISE 45 message, mean speed decreased average of 1.0 (1.47) mph and PCS increased 1.02 (0.57) mph compared with the driver responses to a blank message. Mean speed was reduced in 55.67% of the cases, and PCS decreased in 55.56% of the cases. These special cases, more abundant in this year than the prior year, suggest a slightly positive average effect ACMS, with speed reductions more often than speed increases, and very small effect on PCS.

However, the fact that drivers slowed after the CMS when visibility was worse, but increased their speed when the visibility was better after the CMS, regardless of the CMS message, seems to confirm

observations from the prior year. Again, note that the magnitude of the difference are not as important as the sign, since these charts do not reveal severity of the fog density change between the sties, only that it was different. And since it was much more common for fog to be worse after the CMS during warning message displays, it is most likely that average visibility was not only more often worse after the CMS, but that when it was better, the difference was not as great.

Over all cases in both years of observation, these observations seem suggest that CMS messages may have exerted a small influence beyond the natural behavior drivers, but that the probable effect on traffic safety was, at best, a neutral. The results seem to confirm that drivers responded predominantly to their own perceptions of the conditions rather than the CMS message.

2.9.6 Cumulative response segregated by fog or no-fog

Table 2.9.6.1 presents composite results over all periods during which fog was present or not present at each of the four sites. A breakdown by lane is included to possibly reveal different responds by traffic in different lanes. Observation of speed STD on an individual lanes basis also helps to remove the normal effects of different lane speeds. Lane 3 is used primarily by trucks for which the speed limit is 55 mph, while lane 1 is used exclusively by cars and light trucks, for which the speed limit is 70 mph.

Table 2.9.6.1. Cumulative results discriminated by fog or no-fog periods at each site. Fog is defined as visibility less than 500 feet.

Site 4 (BCMS) No Fog			
Type	Mean Speed	Speed STD	PCS
All Lanes	68.66	7.45	35.46
Lane 1	73.84	5.16	45.99
Lane 2	68.37	6.08	32.60
Lane 3	62.39	6.41	25.42

Site 4 (BCMS) Fog			
Type	Mean Speed	Speed STD	PCS
All Lanes	65.3	7.44	40.49
Lane 1	70.57	5.67	53.11
Lane 2	65.28	6.18	38.46
Lane 3	59.36	5.97	28.65

Site 1 (BCMS) No Fog			
Type	Mean Speed	Speed STD	PCS
All Lanes	68.44	7.3	35.23
Lane 1	73.99	5.17	45.70
Lane 2	67.89	5.23	32.58
Lane 3	62.14	6.32	25.33

Site 1 (BCMS) Fog			
Type	Mean Speed	Speed STD	PCS
All Lanes	65.24	7.5	40.45
Lane 1	70.92	5.85	53.36
Lane 2	65.06	5.69	38.31
Lane 3	59.18	6.11	28.77

Site 2 (ACMS) No Fog			
Type	Mean Speed	Speed STD	PCS
All Lanes	70.58	7.25	36.73
Lane 1	75.42	5.1	48.58
Lane 2	69.04	5.67	34.72
Lane 3	63.72	6.79	16.64

Site 2 (ACMS) Fog			
Type	Mean Speed	Speed STD	PCS
All Lanes	65.78	7.4	48.90
Lane 1	70.56	5.61	58.72
Lane 2	64.32	6.22	46.64
Lane 3	59.81	6.71	35.28

Site 5 (ACMS) No Fog			
Type	Mean Speed	Speed STD	PCS
All Lanes	70.66	7.13	36.10
Lane 1	75.14	4.61	47.70
Lane 2	70.06	5.64	34.28
Lane 3	63.33	6.91	17.55

Site 5 (ACMS) Fog			
Type	Mean Speed	Speed STD	PCS
All Lanes	66.65	7.18	50.01
Lane 1	71.14	5.16	59.36
Lane 2	66	6.04	48.64
Lane 3	60.09	6.42	36.39

Note again that Sites 4 and 1 were the before-CMS (BCMS) sites, and Sites 2 and 5 were the after-CMS (ACMS) sites. This view of the data shows, in the most consolidated way, the response of drivers in fog at the AMCS vs. the BCMS sites, aware that the ACMS sites benefited from the display of a warning

message during all fog periods. To assure that fog messages were indeed displayed during all fog periods at the ACMS sites, we restricted the data to the periods extending from two hours before to two hours after those events in which the CMS actuated with one or both fog messages. This reduced the total number of detections considered in the table from the total of 118 million vehicles to 3.5 million over the two-year period. There is one exception: This data set covers two years, but during the first year only, when visibility dropped below 100 feet, no message was displayed, and we did not remove these periods from the data for the ACMS sites. However, the prior subsection of this report reveals that drivers generally reacted to no message at extremely low visibilities in the same way that they did when visibilities were between 100 and 200 feet, for which the 30 mph advisory message was displayed. It is also questionable if drivers could even see a CMS message at visibilities below 100 feet while traveling at mean speeds of 60 mph, since this allows only 1.10 seconds during which the CMS was readable.

One other caveat: this view of the data does not adjust for the continuous range of visibilities that comprise the fog and no-fog periods considered, and these are known to be different between the BCMS and ACMS sites. If visibility falls below 500 feet, it is classified as "fog"; if visibility is greater than 500 feet, it is classified as "no-fog".

Volume in the dataset at each site were nearly identical, encompassing approximately 870,000 vehicles at each site, since the vehicles considered at each site were usually the same, except for slight dilution due to on/off ramp and transport lag.

Considering the all-lanes data: Drivers at the first BCMS site (Site 4) naturally reduced their mean speed an average of 3.4 mph in fog. For the second BCMS site (Site 1), drivers naturally reduced their mean speed by 3.2 mph in fog. At the first ACMS site (Site 2) drivers reduced their speed by 4.8 mph in fog. At the second ACMS site, drivers reduced their speed 4.0 mph in fog. On average, mean speed decreased 3.3 mph BCMS and 4.4 mph ACMS, a difference of 1.1 mph that could be attributed to the incremental effect of the CMS messages.

Changes in the standard deviation of speed between all sites in all cases were insignificant. Across all lanes at each site, the speed standard deviation remained between 7.1 and 7.5 mph regardless of visibility.

At the first BCMS site, drivers increased their average PCS 5.0 mph in fog. At the second BCMS site, drivers increased their PCS by 5.21 mph in fog. At the first ACMS site, drivers increased their PCS by 12.2 mph in fog. At the second ACMS site, drivers increased their PCS by 13.9 mph in fog. On average, PCS increased 5.1 mph BCMS and 13.1 mph ACMS, a difference of 8.0 mph which could be attributed to the incremental effect of the CMS messages.

These observations are the most compelling of all the views of the data supporting a definitive incremental effect of the CMS message beyond the natural response of the drivers: an incremental speed reduction of 1.1 mph and an increase in PCS of 8.0 mph. Ramifications for traffic safety are

contradictory: the speed reduction suggests increased safety, while the increase in PCS suggests decreased safety. The considerably greater change in PCS can be partially, but not entirely, explained by the mean speed decrease. Reasons for this difference will be discussed in the following subsection.

Examining this data by lane, it may be inferred that the greatest incremental effect of the CMS on speed was in lane 2 (-1.43 mph), and least incremental effect was in lane 3 (-0.58 mph). The median effect was in lane 1 (-1.26 mph). This implies that drivers in lane 2 were either more likely to decrease their speed as a result of the CS, or decreased it a greater amount as a result of the CMS. If one assumes that the most cautious drivers are more likely to be found in lane 2 than in lane 1 (high speed lane) or lane 3 (truck lane), the previous suggested explanation would be further confirmed.

Observing PCS on a per-lane basis, the greatest increase in PCS relative to the natural behavior of drivers in fog occurred in lane 3 (+15.41 mph), followed by lane 2 (+7.35) and lane 1 (3.52). However, in absolute terms, PCS remained the highest in lane 1 at all sites, BCMS and ACMS, most likely as a result of the higher speeds.

The combined observations for mean speed and PCS in lane 3 could potentially be explained by noting that lane 3 has the highest proportion of class 5-8 trucks. Perhaps, as a class, truck drivers heed the warning messages the least, but are the most egregious offenders in terms of separation distance when forced to slow down by a rare individually compliant vehicle. This is understandable since the mean speeds in lane 3 are naturally the lowest in both fog and no-fog conditions, typically 60 mph, compared with 71 mph in lane 1 in fog. These observations are consistent with those of Figure and Figure which show the least difference ACMS vs. BCMS in speed as a function of visibility for long vehicles (assumed to be trucks).

Regarding lane 1, if inferred by PCS, collision danger would remain the highest, but the incremental increase in PCS attributable to the CMS would be the minimum of all lanes.

One other observation may be of some limited value, the difference in the mean speeds between lanes BCMS and ACMS in fog (either in an absolute sense or compared with the no-fog condition: For the two ACMS sites, in fog, the average difference between the mean speed in lane 1 and the mean speed in lane 3 was 10.9 mph. At the BCMS sites, the average difference was 11.2 mph. For comparison, under no-fog conditions, these values were 11.8 ACMS and 11.7 BCMS. In no-fog conditions, essentially no change in inter-lane speed spread is observed ACMS vs. BCMS. Inter-lane spread of speeds naturally reduces in fog by 0.5 mph based on the BCMS data. But in fog, inter-lane speed spread is reduced 0.3 mph more at the ACMS sites than at the BCMS sites, suggesting some incremental effect of the CMS messages. The difference, however, is small and of questionable significance. This seems to supplement the observation of very little change in the speed standard deviation ACMS vs. BCMS under both fog and no-fog conditions.

2.9.7 A Detailed View of Traffic Response to Fog and Fog Advisory Messages

In the prior subsection we concluded that the CAWS CMS message was associated with an incremental speed reduction of 1.1 mph and an increase in PCS of 8.0 mph. Ramifications for traffic safety are contradictory: the speed reduction suggests increased safety, while the increase in PCS suggests decreased safety. It appears that the system is achieving its desired affect. At least some subset of drivers is responding to the warning messages by decreasing their speed, although not nearly as much as advised: mean speeds remain above 60 mph even when visibility is below 200 feet. But as only a minority of drivers comply, the relative safety of the following distances, as indicated by PCS, are possibly being compromised – an unintended effect of almost any traffic management intervention intended to reduce traffic speeds (including reduced statutory speed limits).

A detailed inspection of platoon and individual vehicle behavior during fog events revealed two phenomena responsible for the concurrent decrease in mean speed and increase in PCS:

1. PCS is based on the minimum of the visibility distance or the following distance. When speeds are excessive for the visibility conditions, the visibility distance determines the PCS. If visibility gets progressively worse, PCS increases unless there is a commensurate decrease in speed. For example, as visibility decreases from 200 to 100 feet, a vehicle traveling at a constant 60 mph will report an increase in PCS from 39.9 mph to 55.6 mph. For PCS to remain 39.9 mph as the vehicle moves into the 100 ft visibility zone would require a speed decrease to 47.7 mph. Yet the prevention of multi-car collisions in fog requires exactly this. This explanation is pertinent to sparse traffic, typical during night and early morning hours. Since the overwhelming number of fog events occurred during these time periods, and in most cases the visibility gradient worsens as drivers transition from before to after the CMS, this phenomena is responsible for the majority of the 8.0 mph mean increase in PCS reported over all fog events.

2. In higher traffic densities, such as those encountered during the morning rush hour, a different phenomenon was observed. A subset of drivers slow down a few mph. The majority ignore the CMS. Those that slow down build more densely packed platoons behind them that persist for at least the 1.1 miles from the CMS to the second 'after' site. The response of traffic is demonstrated in Figure 2.9.7.1 below, a pictorial diagram of actual traffic observed before and after viewing the warning message "DENSE FOG AHEAD, ADVISE 45 MPH" on December 17, 2004 at approximately 7:10 AM. Visibility at all sites was approximately 200 feet.

Approximately the same group of vehicles is depicted (matched by vehicle length and queue position), adjusted appropriately for travel time at each site. This view shows the apparent effect of a single vehicle slowing down, creating a platoon of increased density behind it. The net effect is manifests as a reduction in mean speed, and even a decrease in speed variance since all vehicles in each platoon tend to conform closely to the same speed. But PCS reveals the effect of the reduction in the following distances inside the platoon.

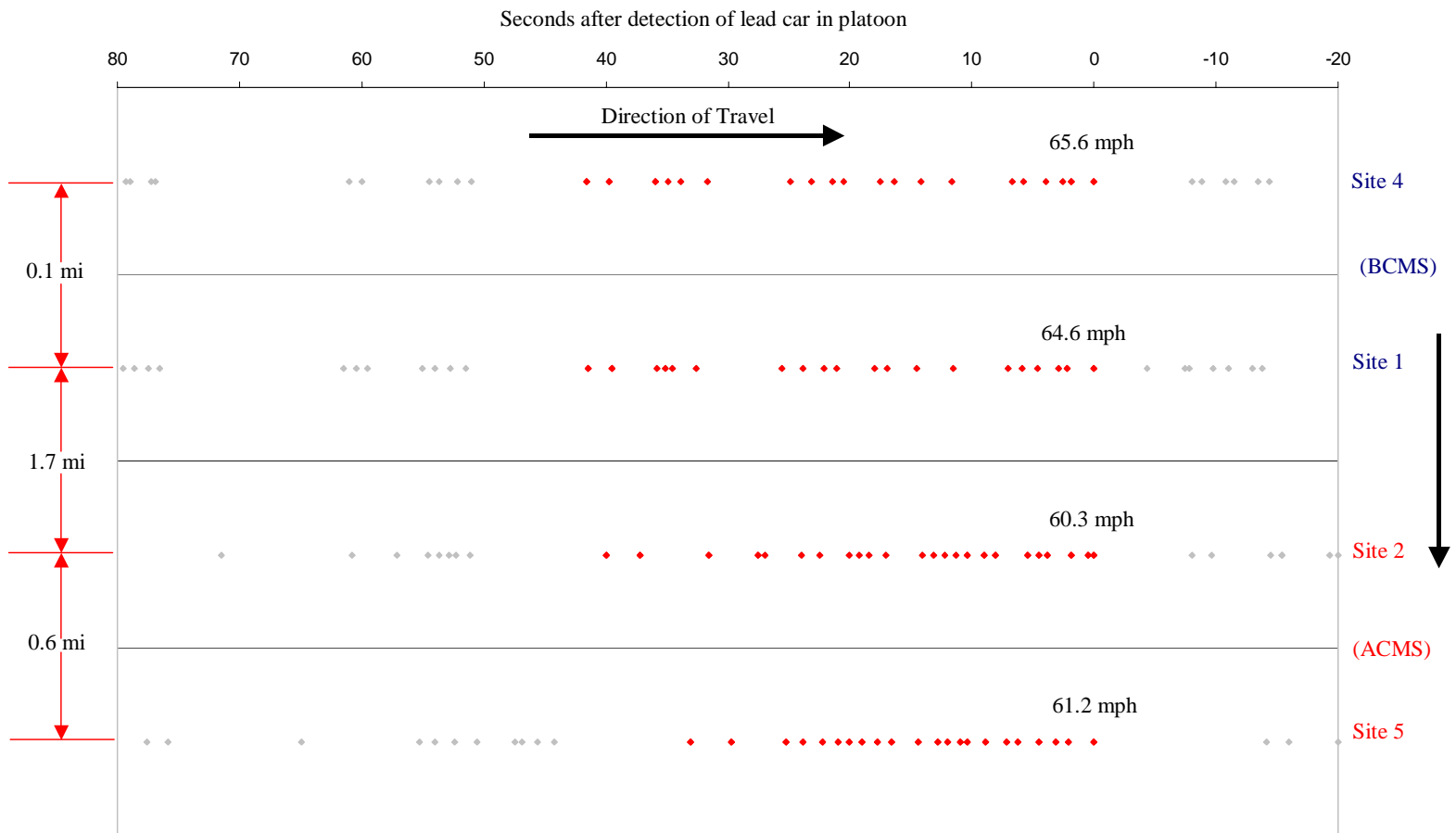

Figure 2.9.7.1. Traffic characteristics before and after CMS warning.

2.9.8 Driver Response to Messages Displayed When Visibility Conditions are Equal

Aware that the visibility gradient between the sites could contribute much of the reported mean increase in PCS during fog, we wanted to make sure that the 8.0 mph increase in mean PCS (that accompanied the 1.1 mph mean speed decrease) during all fog conditions was actually due to the CMS message rather than the natural driver response to worsening visibility after the CMS compared to before the CMS.

We identified just those few situations in which the visibility distance was nearly equal (within 10%) before and after the CMS, and a fog warning message was displayed. This removed any bias on driver behavior of a visibility gradient between the before and after sites, better isolating just the effect of the CMS message. It also assured that a fog message was actually displayed when it was warranted, since we are aware that due to system response lag, the message is not always aligned with the visibility level. Over the two-year period of the driver behavior evaluation, these conditions were observed a total of 13 times, listed in Table 2.9.8.1 below.

In this table PCS* refers to potential collision speed calculated using only the vehicle separation distance, instead of the minimum of the vehicle separation distance or the visibility distance. This removes the visibility distance on the PCS calculation, which represents just the effect of the following distance (even if

the driver can't see the vehicle they are following). Sep PCS is the minimum of the separation distance or the visibility difference used by the PCS calculation, while Sep Raw is the actual vehicle separation (following) distance. Gap Raw is the generally accepted inter-vehicle gap time measurement for individual vehicle pairs, measured in seconds. Gap PCS is the lesser of (1) the time that would be required for a vehicle to travel from its current position to the current position of the vehicle in front of it in the same lane (regular gap), or (2) the time that would be required for a vehicle to travel the current visibility distance.

Table 2.9.8.1. Periods in which a 45-mph fog warning message was displayed while visibility was equal BCMS and ACMS.

Start	Dur (sec.)	Site	Mean Speed	PCS	PCS*	Sep_PCS (ft.)	Sep_Raw (ft.)	Gap PCS	Gap Raw	Veh Count	Avg Vis	Vis (Ft)
20031108021758	168	BCMS	68.02	8.41	8.41	1401.25	1920.10	20.48	28.03	41	10.58	1497.16
		ACMS	71.30	8.13	8.13	628.21	2573.26	8.93	36.53	28	10.00	1584.26
20031222005932	360	BCMS	60.88	18.75	9.03	300.35	1910.98	5.01	30.71	74	77.86	203.44
		ACMS	62.66	46.62	9.15	172.26	2578.89	2.82	40.97	71	82.36	192.33
20040111070249	2338	BCMS	67.30	49.31	18.08	204.73	995.41	3.08	14.92	1362	70.29	225.34
		ACMS	68.77	46.54	17.07	232.59	1181.79	3.42	17.44	1163	64.51	245.56
20040123084310	1079	BCMS	64.27	54.88	39.40	138.57	308.08	2.17	4.78	1833	87.33	181.38
		ACMS	63.91	54.68	37.96	136.62	348.26	2.16	5.56	1631	85.31	185.68
20041209223252	531	BCMS	68.17	16.87	16.87	689.25	1039.53	10.20	15.18	296	17.69	895.28
		ACMS	68.14	28.06	15.97	373.97	1085.95	5.57	16.07	280	18.60	851.64
20041211045037	540	BCMS	68.39	52.55	15.36	196.43	1184.98	2.90	17.48	257	73.34	215.97
		ACMS	67.88	51.13	15.95	199.23	1233.74	2.97	18.48	243	79.80	198.50
20041219041613	710	BCMS	67.48	6.78	6.78	659.59	2125.48	9.87	31.64	190	22.01	719.59
		ACMS	67.73	5.41	5.41	600.49	2374.78	8.96	35.17	151	21.83	725.65
20041220040114	169	BCMS	68.70	24.67	24.67	540.53	540.53	7.94	7.94	175	8.29	1911.50
		ACMS	70.34	24.23	24.23	561.86	722.48	8.15	10.53	136	8.56	1850.83
20041224043713	710	BCMS	70.67	14.54	14.44	604.70	1135.88	8.67	16.37	371	21.27	744.78
		ACMS	70.37	13.58	13.55	527.99	1204.45	7.57	17.47	335	21.68	730.64
20041224211013	17632	BCMS	68.09	29.39	20.52	334.28	1097.18	4.96	16.34	9476	38.15	415.15
		ACMS	67.13	29.15	20.04	313.75	1122.49	4.71	16.98	9131	40.97	386.60
20041225033713	13850	BCMS	69.55	13.18	9.43	462.66	2568.56	6.73	37.76	3217	32.37	489.37
		ACMS	69.56	15.40	9.43	427.35	2880.71	6.21	42.54	2874	35.26	449.24
20050113004414	2339	BCMS	63.76	44.54	6.71	195.16	2657.75	3.10	41.98	488	89.84	176.31
		ACMS	60.53	47.06	6.85	157.54	2671.16	2.64	44.52	459	96.71	163.78
20050205073913	2700	BCMS	67.94	47.70	32.21	245.80	503.45	3.63	7.45	3052	65.96	240.15
		ACMS	69.67	50.82	32.42	209.62	548.28	3.04	7.99	2864	65.84	240.59

Time Weighted Averages											
Site	Mean Speed	PCS	PCS_Raw	Sep_PCS	Sep_Raw	Gap PCS	Gap Raw	Veh/h	Avg Vis	Vis (Ft)	
BCMS	68.16	27.20	16.72	367.64	1617.70	5.42	24.07	1738.98	43.56	421.11	
ACMS	67.80	28.30	16.41	334.98	1758.18	4.96	26.42	1616.60	45.78	396.22	

Over this very selective class of events, we observe that vehicles reduce their speed an average of 0.36 mph between the before and after sites. During this speed reduction, PCS increases 1.1 mph, but PCS* decreases 0.31 mph. In other words, when visibility change is not a factor in differential driver behavior at each site, and when we are sure that drivers are actually viewing a warning message, drivers reduce their speed an average of about 1/3 mph between the sites. There is still a visibility gradient (mean visibility changes from 421 feet before the CMS to 396 feet after the CMS, and this probably accounts for the most of the 1.1 mph increase in PCS, since PCS* decreases an amount almost identical to the speed decrease. Under these conditions, the speed reduction is very small, but the physical separation between vehicles is not being compromised by this reduction in speed.

It's important to remember, however, that drivers naturally increase their speed as they travel from the BCMS to the ACMS sites. We need then to examine the results above relative to this baseline behavior. Unfortunately, we have no equivalent data on conditions in which visibility conditions were identical and no message was displayed *in fog*, but these requirements are the norm in clear weather.

Figure 2.9.1.1 shows that in visibility above 500 ft., drivers generally travel about 1.0 mph faster after the CMS than before the CMS, while Figure 2.9.1.4 shows almost no average difference in PCS. This suggests a speed reduction of $1.0 - (-0.36) \approx 1.4$ mph that could be attributed to the CMS message alone, with almost no change in PCS other than the effect of the visibility change between the sites.

Unfortunately, the rarity of these conditions leads us to be reluctant to infer too much from these results. We note that in more than half the events reported in Table 2.9.8.1 vehicles actually increased their speed while traveling from the BCMS to the ACMS site; the 0.36 mph reduction is due to the time-weighting of the longest events on December 24, 2004 and January 13, 2005. Yet we feel that this analysis is worth presenting since it represents the maximum extent to which it may be possible to isolate the effect of the CAWS warning message from the natural behavior of drivers under the same conditions without the CAW.

2.10 CAWS Driver Response Conclusions

Over a two-year period of evaluation, a record of every vehicle on southbound I-5 was acquired at four monitoring sites; two before and two after the first changeable message sign encountered by drivers entering the CAWS area on I-5. We assessed the response of drivers by observation of the traffic before and after the CMS, and during the time periods before, after and during the CMS display. We examined every event which activated the CMS for fog, traffic or wind.

The event history plots generally show that during the display of fog messages on the CMS, mean traffic speed usually decreases by 2-3 mph after the CMS compared with before the CMS. Changes in speed standard deviation between the before and after CMS sites do not seem to be significant during these events. Potential collision speed increases dramatically in fog, and typically increases after the CMS, more so in fog than in non-fog conditions.

When plotted as a function of visibility, no significant change is evident in any metrics between the natural responses of the drivers to visibility conditions after the CMS compared with before the CMS. No incremental effect can be attributed to the CMS advisory messages affecting the ACMS sites.

Over all periods in which a CMS message was displayed, there is some evidence that a message may slightly enhance the existing tendency of drivers to reduce mean speed and increase PCS as visibility decreases.

By segregation of measurements of each metric at each site, in fog and not in fog, it is possible to isolate to a greater degree the effect of the CMS message from the natural response of the drivers: The CMS messages appeared to be responsible for an average incremental speed reduction of 1.1 mph and an average increase in PCS of 8.0 mph. The speed reduction suggests increased safety, while the increase in PCS suggests decreased safety. Two phenomena explain this apparent paradox. In sparse traffic, PCS usually increases because visibility is more often worse ACMS than BCMS. Since PCS depends on the minimum of the following distance and the visibility distance, PCS increases when widely separated vehicles in fog experience a decreasing visibility gradient. In more dense traffic, PCS usually increases because a minority of drivers heed the speed advisory message and reduce their speeds slightly. This reaction leads to more densely packed platoons as the majority of drivers, who ignore the CMS message, accumulate behind the conforming drivers and reduce their separation distance to dangerous levels for the given speed and visibility level.

When we isolated the rare conditions of nearly equal visibility before and after the CMS while a fog message was displayed, we found a mean speed decrease from before to after the CMS of 0.36 mph and an insignificant change in PCS. Noting that drivers generally increase their speed by an average of 1.0 mph after the CMS in clear weather, it can be inferred that the CMS message, when isolated from the natural influence of visibility on driver behavior, may affect a speed reduction of up to approximately 1.4 mph with only a very small change in PCS. This result is probably a good indicator of the potential ability

of the CAWS to affect driver behavior in fog when CMS warning messages are properly aligned with the triggering visibility conditions. Unfortunately, the rarity of these conditions and observations leads us to be reluctant to infer too much from these results.

During fog event events, drivers continue at mean speeds consistently above 60 mph even in visibilities below 100 ft. Mean speeds in visibility as poor as 700 feet do not vary from speeds under clear conditions, typically 69-71 mph over all lanes, and 74-76 mph in lane 1. Speed standard deviation seems almost invariant with visibility conditions, staying within the range of 5-7 mph. In fog, PCS values between 45 and 60 mph were typical. PCS values during moderate traffic averaged 20-30 mph. Note that if PCS approaches equality with the mean traffic speed, every vehicle on the highway would collide with an obstruction such as a prior collision without ever having the chance to brake. Or equivalently, a rear-end collision could not be avoided even in the case of aggressive but otherwise controlled braking of a lead vehicle.

Based on the response of drivers to the first CMS of the CAWS, there is evidence that the CMS influences traffic in a small measurable way, but that the safety ramifications of this influence are, at best, neutral due to a somewhat greater incremental increase in PCS than the decrease in mean speed. Speed standard deviation appears to degrade slightly under these conditions, but rarely over 1 mph. Drivers appear to predominantly make their own decisions about safe speed and separation distances for given conditions. It may, however, be possible that the CAWS also influences drivers in non-measurable ways, such as increased alertness, even if indications of potential collision risk/severity increase.

During dense fog, PCS becomes markedly worse in all vehicle classes and lanes both before and after the CMS. While PCS is not an indicator of all collision types, it is physically linked to the predominant type of collision in fog – the rear end collision and resultant chain collisions. For a vehicle to avoid adding itself to an existing multi-car collision, it would have to have a PCS of zero. Yet speeds consistently above 60 mph and PCS values of 45-60 mph are consistently observed, regardless of messages advising speeds of 30 or 45 mph. The reported incremental speed reduction of 1.1 mph is a positive influence, but a much more substantial decrease in mean speed and PCS must be achieved if a significant reduction in the risk and severity of multi-car chain collisions is to be achieved.

2.11 Appendix

2.11.1 Significant actuation events for CAWS CMS 1, November 2003 – February 2005.

CD Attached.

Complete data, tables and plots in directories as .xls files, prepared in Excel 2000.

Event classification type codes:

DBF - Driver Behavior Fog

DBO - Driver Behavior Other (manually activated messages)

DBS - Driver Behavior Speed (slow, stopped, highway advisory)

DBW - Driver Behavior Wind

PRB - Problem with CMS Messaging

Date format: YYYY-MM-DD

Year 1: 2003-04

DBF-2003-11-01

PRB-2003-11-16

PRB-2003-11-18

PRB-2003-11-19

DBF-2003-12-15

DBF-2003-12-21

DBF-2003-12-22

DBF-2004-01-02

DBF-2004-01-08-09

DBF-2004-01-22-23

DBS-2004-03-01

DBF-2004-03-08

DBS-2004-03-11

DBS-2004-03-13

DBO-2004-03-17

DBW-2004-04-01

DBO-2004-04-02

DBS-2004-04-17

DBW-2004-04-28

DBO-2004-04-30

DBS-2004-05-06

DBWO-2004-05-21

DBO-2004-05-23

DBO-2004-05-25

DBS-2004-05-27

DBS-2004-06-28

Year 2: 2004-05

DBO-2004-07-05

DBS-2004-07-22

DBS-2004-08-03

DBO-2004-08-09

DBS-2004-08-29

DBS-2004-09-01
DBWO-2004-09-09
DBS-2004-09-24
DBS-2004-09-30

DBO-2004-09-15
DBO-2004-09-29

PRB-2004-10-31
DBW-2004-10-19
DBS-2004-10-14

DBO-2004-10-11
DBF-2004-11-14
DBF-2004-11-14-15
DBF-2004-11-15-16
DBF-2004-11-16-17
DBF-2004-11-17
DBF-2004-11-19-20

DBF-2004-11-07
DBF-2004-11-11-12

DBO-2004-12-03
DBF-2004-12-09
DBF-2004-12-10-11
DBF-2004-12-13
DBO-2004-12-15
DBF-2004-12-16-17
DBF-2004-12-17-18
DBF-2004-12-18-19
DBF-2004-12-19-20
DBO-2004-12-21-22
DBF-2004-12-23
DBS-2004-12-23
DBF-2004-12-23-24
DBF-2004-12-24-25
DBF-2004-12-25-26
DBS-2004-12-28

DBF-2005-01-03-04
DBW-2005-01-07
DBF-2005-01-12-13
DBO-2005-01-17
DBF-2005-01-20
DBF-2005-01-21
DBF-2005-01-22
DBF-2005-01-24

PRB-2005-02-02
DBF-2005-02-03
DBF-2005-02-04
DBF-2005-02-05
DBF-2005-02-17
PRB-2005-02-22